

NORGES LANDBRUKSHØGSKOLE
Agricultural University of Norway

DOCTOR SCIENTIARUM THESES 1995:27

**TROPICAL RAINFOREST DEFORESTATION, BIODIVERSITY BENEFITS AND
SUSTAINABLE LANDUSE: ANALYSIS OF ECONOMIC AND ECOLOGICAL
ASPECTS RELATED TO THE NGURU MOUNTAINS, TANZANIA.**

Gerald C. Monela

FOR REFERENCE
ONLY

Institutt for skogfag
Norges landbrukshøgskole
Postboks 5044, N-1432 Ås

Department of Forest Sciences
Agricultural University of Norway
P.O.Box 5044, N-1432, Aas
Norway

ISSN 0802-3220
ISBN 82-575-0266-9

ABSTRACT

Monela, G.C. 1995: Tropical rainforest deforestation, biodiversity benefits and sustainable landuse: Analysis of economic and ecological aspects related to the Nguru mountains, Tanzania. Doctor Scientiarum Theses 1995:27, ISSN 0802-3220.

The threat to the rainforest in the Nguru mountains due to landuse problems is serious. Because of the strong link between agriculture and forest degradation, any attempt to alleviate ecological problems must to a large extent address agricultural-related landuse problems. The primary objective of this study is to analyze the possibilities for sustainable integrated management of land-based resources and ecological conservation in the Nguru mountains in order to improve the living standard of the people and preserve the tropical rainforest in the area. More specifically, landuse practices are analyzed and micro-economic analysis is used to evaluate the efficiency in resource use. Mathematical programming is applied in an empirical case study to examine the impact on deforestation pressure, of agriculture, population pressure and risk. It is also used to formulate economically efficient farm plans at household farm level in order to analyze the potential for improving people's income and resource use. The study is presented in form of three reports titled as follows:

- Report 1. Rainforest degradation and landuse in the Nguru mountains, Tanzania: Analysis of socio-economic and ecological aspects.
- Report 2. Analysis of the use of tropical rainforest species and evaluation of buffer zones and other control mechanisms in preserving the tropical rainforest adjacent to Mhonda village in the Nguru Mountains, Tanzania.
- Report 3. Socio-economic analysis of deforestation of tropical rainforests as a consequence of agriculture productivity, risks and population growth: A case study of Mhonda village in the Nguru mountains, Tanzania.

Results show that several interrelated factors are main driving forces for landuse problems which enhance deforestation pressure in the Nguru mountains. These include poverty, growing population, increased domestic demand, lack of knowledge, and risk. The effect of these factors is enhanced by market and government failures which are partly influenced by demands external to the country. These factors must be considered to improve farming practices and landuse, prevent excessive use of the rainforest, and reduce deforestation pressure and degradation. No single solution exist for these landuse problems, yet the insights gained through the analysis done provide information to alleviate the situation.

Key words: Tropical rainforest, deforestation, biodiversity, buffer zone, landuse planning, risk, agriculture, socio-economic analysis, compromise programming.

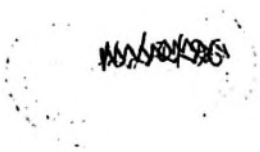

PREFACE

My interest in multi-resource forest management and landuse planning issues dates back to 1990 when Professor G.S. Kowero and Dr. A.R.S. Kaoneka at the Department of Forest Economics, Sokoine University of Agriculture (SUA) - Morogoro, in collaboration with Professor Birger Solberg, at that time, of the Department of Forest Economics - Agricultural University of Norway (AUN) and Professor D.P. Dykstra, then at Northern Arizona University (NAU), Flagstaff - USA, initiated the idea and played a crucial role in facilitating my admission to NAU for training in multi-resource forest management, landuse planning and modeling techniques. The topic of this dissertation was formulated after completion of training at Northern Arizona University. Professor Birger Solberg responded positively to my research idea and took up the task of being my main supervisor at the Department of Forest Sciences, Agricultural University of Norway. This dissertation is also a result of the information I collected for one year in Mhonda village and areas around in the Nguru mountains, Tanzania. In pursuit of this work, a number of people and institutions were of great assistance in different capacities.

Space does not allow to mention each one by name but I wish to express my deeply felt gratitude to them all. For special thanks however, I must single out the following persons and institutions. Professor Birger Solberg, my supervisor who deserves special gratitude first for accepting me as his student and also for his intellectual stimulation, professional guidance, critical comments, encouragement and sincere interest in this study from its formulation to its completion. His devotion for this work, cooperation and inspiration made even difficult times bearable. The role of Ms. Kari, his wife, in providing motherly moral and logistical support during my stay at Aas is highly appreciated. Dr. A.R.S. Kaoneka at the Department of Forest Economics, SUA, introduced me to Compromise Programming technique, which is the basis of the model developed in the present study. His moral and practical support during our studies at NAU, AUN and at SUA is highly appreciated. Dr. Prem Sankhayan, Senior Economist, Centre for International Environment and Development Studies - NORAGRIC, Aas, introduced me to GAMS software, its capabilities and application to the present study. His encouragement, moral and practical support is highly appreciated. Professors Ole Hofstad and Asbjørn Svendsrud, both at the Department of Forest Sciences, AUN, read and critically commented on the thesis summary. Mr. Sjur Baardsen of the Department of Forest Sciences, AUN and Mr. R.S. Wærås of the Norwegian Forestry Research Institute (NISK), AUN, provided assistance for problems related to the computer network. Their commitment to assist is highly appreciated. Ms. Marie Steen Rønnestad of the Department of Economics and Social Sciences, AUN helped me to access UNIX machine for running GAMS package. Mr. Y.M. Ngaga, a fellow Dr. Scient. student and colleague, read the thesis summary and shared with me many ideas and discussions during our stay at AUN.

During field work in Tanzania, the Department of Forest Economics and Faculty of Forestry, Deans Office, SUA, provided logistical support. Various Government Offices facilitated collection of secondary data. The Morogoro Region Catchment Forest Project, Morogoro Region Cooperative Union, the Marketing Development Bureau, the Bureau of Statistics, the Division of Forestry and Beekeeping and the Mapping and Land Survey Division - Dar es Salaam, deserve special mention. Peasant farmers, local leaders and Government agents in Mhonda village and

villages around in the Nguru mountains devoted their time to respond to continuous interviews throughout the year and allowed us to pry into their privacy. Their cooperation will always be remembered. Messrs. A.S. Kigona, C.O.B.Z. Jamal, E.F. Mazengo, D. Mwaikenda and Mr. Kimu helped me to conduct interviews and field observations. The Royal Norwegian Agency for Development Cooperation (NORAD) sponsored this study. NORAGRIC handled my financial and accommodation matters as well as travel arrangements. The Department of Forest Sciences, AUN, accepted me as a Dr. Scient. student and provided moral and logistical support during my stay at Aas. The School of Forestry, Northern Arizona University, Flagstaff, USA, gave me the foundation for multi-resource forest management, modeling and landuse planning. Professor D.P. Dykstra deserves special mention in this connection for facilitating my admission and serving as my supervisor at Northern Arizona University. Sokoine University of Agriculture granted me a study leave to pursue a Dr. Scient. Degree at AUN.

Finally, my beloved wife Edith and our two children Anna and Immanuel, had to tolerate my long absence from home for several years. Nevertheless, my family's understanding, love, unflinching support and patience have been a great inspiration to transform my efforts into a unique opportunity in my development endeavour. I hope to be able to prove to them that the negative externalities they have experienced need not remain genuine externalities in an intertemporal context.

To all these people and institutions, I am deeply thankful. My sincere hope is that this work can be practically applicable in connection with agriculture and forestry to improve resource use and reduce deforestation pressure. The significant and generous contributions of all these people and institutions mentioned above notwithstanding, the final responsibility for this work rests with me.

Gerald C. Monela.

Ås-AUN

November, 1995

DEDICATION

To my parents, Anna Saanane and Claudio Monela, who in their love, patience and subtle ways initiated and inspired me to pursue my studies.

To my wife Edith and our children Anna and Immanuel, who suffer the consequences but remain my richest source of encouragement.

Above all to the Almighty God, for blessing me with the faculty of understanding and giving me the physical, mental and moral strength to accomplish this very important task.

CONTENTS

Contents

SUMMARY

- REPORT NO. 1. RAINFOREST DEGRADATION AND LANDUSE IN THE NGURU MOUNTAINS, TANZANIA: ANALYSIS OF SOCIO-ECONOMIC AND ECOLOGICAL ASPECTS.
- REPORT NO. 2. ANALYSIS OF THE USE OF TROPICAL RAINFOREST SPECIES AND EVALUATION OF BUFFER ZONES AND OTHER CONTROL MECHANISMS IN PRESERVING THE TROPICAL RAINFOREST ADJACENT TO MHONDA VILLAGE IN THE NGURU MOUNTAINS, TANZANIA.
- REPORT NO. 3. SOCIO-ECONOMIC ANALYSIS OF DEFORESTATION OF TROPICAL RAINFORESTS AS A CONSEQUENCE OF AGRICULTURE PRODUCTIVITY, RISKS AND POPULATION GROWTH: A CASE STUDY OF MHONDA VILLAGE IN THE NGURU MOUNTAINS, TANZANIA.

SUMMARY

Introduction

Pressure on the tropical rainforest in the Nguru mountains has escalated in recent years due to growing population and other reasons, influenced by the relatively fertile soils and high rainfall in the area. It has become important therefore, to address agricultural-related landuse problems in order to reduce deforestation pressure on the tropical rainforest. Improved landuse planning is one measure to alleviate these landuse problems in agriculture to reduce deforestation pressure.

Objectives and main working hypothesis of the study

The broad objectives of this study is to analyze the possibilities for sustainable integrated management of land-based resources and ecological conservation in the Nguru mountains in order to improve the living standard of the people and preserve the tropical rainforest in the area.

The more specific objectives are to:

- (i) Assess the existing landuse practices and resources use with reference to forestry and agriculture including types of landuse problems, their causes and impact on deforestation pressure and people's standard of living in the Nguru mountains.
- (ii) Evaluate the use of tropical rainforest species and the role of buffer zones and other control mechanisms implemented in protecting the rainforest and its biodiversity in the Nguru mountains.
- (iii) Assess and apply relevant quantitative techniques to develop economically efficient farm plans at household farm level to increase the long term quality and quantity of production, thus raising people's income and reducing deforestation pressure.
- (iv) Evaluate various policy measures and recommendations for implementation of appropriate farm plans.
- (v) Make recommendations for the future analysis and research in the study area.

Among these objectives, most work concentrated on objective (iii) and (iv). The main working hypothesis for this study is that it is possible to raise the standard of living of the people and preserve the tropical rainforest in the Nguru mountains through improved landuse planning for sustainable resource management.

Organization of the study and connection between reports

The study comprises of two parts: Part I analyzes the existing situation regarding landuse, ecological and socio-economic aspects in the Nguru mountains as a necessary background for the quantitative analysis in the case study. It concentrates on landuse systems, landuse problems, rate and extent of deforestation and role of property rights in landuse. Based on micro-economic analysis it also assesses resource availability, utilization and productivity. The use of rainforest species, biodiversity and control mechanisms for rainforest protection are also evaluated. Part II comprises of an empirical case study in Mhonda village to analyze the impact of agriculture on

deforestation pressure, applying mathematical programming to formulate economically efficient farm plans at the household farm level. The two parts of the study are presented in form of three reports titled as follows:

- Report No. 1. Rainforest degradation and landuse in the Nguru mountains, Tanzania: analysis of socio-economic and ecological aspects.
- Report No. 2. Analysis of the use of tropical rainforest species and evaluation of buffer zones and other control mechanisms in preserving the tropical rainforest adjacent to Mhonda village in the Nguru mountains, Tanzania.
- Report No. 3. Socio-economic analysis of deforestation of tropical rainforests as a consequence of agriculture productivity, risks and population growth: a case study of Mhonda village in the Nguru mountains, Tanzania.

The main issue in this study concerns application of landuse planning at the household farm level to analyze efficient patterns of using scarce resources to improve people's standard of living and mitigate landuse problems that cause deforestation pressure on the rainforest. Report number 1 gives an exposition of main landuses, landuse problems and main factors causing them, their impact on deforestation pressure and people's standard of living. Report number 2 looks into the way people use the rainforest to meet their needs and in so doing cause forest degradation and deforestation pressure. It also evaluates the various measures practiced to control the use of the rainforest and to protect it against the impact of landuse problems such as deforestation pressure.

Based on the background in Reports number 1 and 2 and data collected in Mhonda village, Report number 3 presents an application at the micro level. The aim is to investigate the main causes of observed landuse problems in order to identify appropriate intervention points and measures to rectify the situation. It involves probing of the existing situation by narrowing down the scope to one specific site in the affected area. This is important for a deeper understanding of the peasant farming systems, the constituent processes and their impact on the systems behaviour. It requires synthesis of vital biological, managerial and economic processes of the system. This understanding is important for finding out the real causes of landuse problems, unsustainable behaviour and deforestation pressure. Finally, the case study is used to develop economically efficient farm plans at the household farm level, which can be used to improve farm productivity and income and in consequence mitigate landuse problems that cause deforestation pressure. Therefore, Report number 3 is the heart of the study, but is based on the background information in Reports number 1 and 2. This background is essential in order to understand and appreciate what is in Report number 3. The three reports therefore should be viewed as one entity, especially in methodology and also in the results and general conclusions. The results of the investigation on some issues may be mentioned in more than one report, but are reported with emphasis in one report. Such issues include risk, deforestation, biodiversity, pitsawing and collection from the forest, among others.

Main contents of the reports

Report number 1.

The Nguru mountains in Tanzania form one area where human interference in the tropical

rainforest has in recent years created a threat to the rainforest despite its ecological and socio-economic importance. Therefore the broad objective of this report is to identify the main landuse and landuse problems with reference to agriculture and forestry in the Nguru mountains, and the main factors causing these problems, and analyze ways to reduce them in order to prevent forest degradation and deforestation. The more specific objectives are: (i) to describe the ecological and socio-economic aspects of landuse in the Nguru mountains with respect to forest degradation and deforestation; (ii) to examine the nature and type of landuse practices in the Nguru mountains; (iii) to analyze landuse problems affecting forest resources in this area; (iv) to identify the main factors causing landuse problems there; (v) to recommend possible measures to control landuse in order to prevent forest degradation and deforestation.

The report starts by presenting a review of socio-economic aspects of forest resource management, utilization, degradation and deforestation. This review, first, focuses on the role of property rights in forest resource management and utilization. It is then extended to cover deforestation in general and in Tanzania, addressing its extent, the main causes, impacts and efforts to mitigate it. Based on data collected in villages in the Nguru mountains using interviews (questionnaire survey), field observations, and secondary sources, it is concluded that ecological and socio-economic factors have played an important role in shaping the existing landuse practices, landuse problems and factors causing landuse problems in the Nguru mountains. The role of the ecology of the Nguru mountains in shaping the nature of landuse practices and hence landuse problems, is a result of the strong linkage between forestry and agricultural landuses with the ecology of the area.

The ecology of the Nguru mountains is also of special interest due to its relatively rich and unique flora and fauna. The Nguru mountains also seem to be among the few areas in Tanzania where relatively undisturbed rainforest still exist and where most vegetation belts can still be found. These vegetation types are described in this study and they range from lowland rainforests on the alluvial plains to the altimontane bamboo thickets on the summits of the Nguru mountains. The lowland rainforests have been severely affected by human impacts. The socio-economic environment in the Nguru mountains also seem to have strong linkage to landuse practices and landuse problems in the area. These were examined focusing on anthropological, social, cultural and economic aspects of the local communities, as well as land rights, income opportunities and demographic factors.

The major landuses in the Nguru mountains are agriculture and forestry and relative to other landuses, these have contributed most to the prevailing landuse conflicts. Other landuses are settlements and grazing land. The agriculture is dependent on rainfall, growing mainly subsistence food crops using traditional farming practices. Forestry is conservation forestry mainly for water catchment, but also supplies local communities with both timber and nontimber forest products. Due to the importance of the water catchment objective in the Nguru mountains, the study also presents the catchment role and watershed aspects of the rainforest. An evaluation is made of the activities involved in the Morogoro Region Catchment Forest Project operating in the Nguru South Forest Reserve aiming to improve protection and management of the rainforest. Landuse related issues emanating from this project such as community participation programmes are

assessed with regard to their role in rainforest management, utilization and protection.

The study showed the following main landuse problems in the Nguru mountains: deforestation pressure through encroachment for agriculture, forest degradation through excessive forest product exploitation, frequent and uncontrolled bush fires, land degradation and soil erosion due to inappropriate farming methods caused by poor farming technology and lack of farm inputs, declining crop harvests, squatters inside the Forest Reserve, farming in the buffer zone around the rainforest, and non-adherence to forest control measures. The impact of these landuse problems have been strongest on lowland rainforests, where high rates of rainforest conversion to agriculture and other landuses were observed.

It was found that the main factors causing landuse problems in the Nguru mountains are mainly related to: population growth; land scarcity; search for market goods; increased domestic demand for food and forest products; poverty; lack of knowledge; lack of an effective extension service; market failures such as breakdown of traditional management systems due to commercialization of demand for resources; government failures such as inefficient government policies; risks and uncertainty in farming (pests, diseases and vagaries of climate); insecure land rights under customary land tenure system; traditional or cultural barriers; conflicting objectives between different land users; failure to control protected areas such as Forest Reserves; decline in forest product supply and lack of income from outside agriculture and forestry. The influence of these various forces vary from local agents to the wider dimension. International demands and asymmetry also appear to act as indirect driving forces for landuse problems in the Nguru mountains. The landuse problems and factors causing them are interrelated to form a system causality which can be used to describe the cause-effect phenomenon regarding landuse problems.

From this study, it seems the government has not been able to control landuse problems through policy measures or coercion. Also, the market has not been able to do so due to its failure to provide negative feedback loops to check landuse problems. This is partly due to the widespread market and government failures such as tenurial traditions and policies which provide incentive for poor landuse practices. Vaguely defined, unequitable and uncertain land tenure conditions, lack of knowledge and traditional barriers add a complicating dimension to landuse problems in the Nguru mountains. The rural poor, the direct agents of land and forest degradation in the Nguru mountains, have unreliable access to credit markets due to the absence of guarantees (collateral) caused by lack or uncertainty of tenure. The effect of this has been to enhance landuse problems.

Since the welfare and survival of the people in the Nguru mountains are inextricably linked with agriculture and forests, they must improve current landuse practices in order to come to terms with the reality of resource limitation and carrying capacity of their land and forests. Wise management of land and forest resources requires appropriate landuse practices to improve the standard of living and preserve the biological systems, especially the rainforest upon which they depend. Generally, the strategy recommended requires the following steps: landuse planning at household farm level for efficient use of resources and integrated planning for harmonizing conflict between land users; measures such as family planning to control population growth;

education to enhance change of attitudes on resource use by overcoming communication breakdown between resources users and protectors through direct dialogue and community involvement; giving some specific rights to property in reserved forests and benefits to villagers to meet their needs while protecting the resources; improving traditional landuse systems and traditional knowledge; incorporate agroforestry in farming systems; removal of institutional barriers to wise landuse by government through appropriate policy changes; and improvement of rainforest management methods to enhance forest protection.

Report number 2.

The tropical rainforest in the Nguru mountains is an important ecosystem from the economic and ecological points of view. However, the threat to this valuable resource is widespread. The broad objective of this report is to analyze the use of rainforest species and to evaluate the role of buffer zones and other control mechanisms in preserving the rainforest adjacent to Mhonda village in the Nguru mountains. The specific objectives are: (i) to assess the use and benefit of the rainforest species by local communities; (ii) to assess plant species richness of the rainforest with regard to biodiversity importance; (iii) to assess human impact on species richness inside and on the periphery of the rainforest; (iv) to evaluate the types of control mechanisms currently practiced to protect the rainforest; (v) to evaluate the role of buffer zones in forest control; (vi) to recommend steps necessary for improving protection of the rainforest.

Data were collected using field observations, interviewing farmers randomly sampled in the zone adjacent to the rainforest in Mhonda area, and secondary sources. The results of this report are presented in the context of species richness of the tropical rainforest in the Nguru mountains and use of these species by local communities to meet their needs. Attention is also given to endemic species with potential economic value. The mechanisms currently practiced to control the use of the rainforest are also presented with focus on forest law enforcement, role of buffer zones, and community involvement in forest management. The botanical survey in the rainforest to assess existing species richness enumerated a total of 176 species, 72 plant families and 165 genera. Of these enumerated species, 26 species (15%) are known to be endemic in the Eastern Arc mountains of Tanzania whereas 7 (4%) are specifically endemic to the Nguru mountains. About 19 species (11%) were enumerated in the zone adjacent to the rainforest. The difference in species composition between the core rainforest and the zone adjacent to it is mainly due to intense human impacts emanating from landuse problems. Many species in the rainforest are used locally for various purposes. Out of the enumerated species, 5% are used for timber, 41% for food related purposes, 14% for firewood, 10% for local medicine, and 4% for other uses. 31% of the species had no specific uses. Most of the forest products for local use are collected freely from the rainforest. The value of forest products consumed by an average household per year was estimated by ethnobotanical and local market survey and found to be about T.Shs. 237000. This contributes about 39 percent of the total household consumption valued at market prices. The value of nontimber forest products constituted the greatest proportion of forest products consumed by the household and their value was influenced by species in the forest (i.e. floristic richness), access to or proximity to the market, local policy and property rights regime with regard to forest ownership and control.

However, timber species harvested by pitsawing underline the single important commercial use of the rainforest biodiversity. The main species for timber from the rainforest are: *Milicia excelsa*, *Caephalosphaera usambarensis*, *Ocotea usambarensis*, *Entandrophragma stolzii*, *Podocarpus milanjanus*, *Pterocarpus angolensis* and *Khaya nyasica*. The timber is used for furniture, building and local crafts. Some endemic species in the area have potential commercial value and use in horticultural or breeding programmes. The endemic coffee species (*Coffea mongensis*) and spices have potential use in breeding to improve commercial varieties. The African violet flower (*Saintpaulia spp.*) have potential use in horticulture. The abundant fat-producing seed from *Allanblackia stuhlmanii* have potential commercial use in producing edible oil and oil for soap and candle industry. It was found that these useful species and others are threatened by biodiversity loss mainly caused by excessive exploitation of the forest and forest clearing.

Several forest control mechanisms to protect the rainforest from undesirable human impacts were found, ranging from institutional aspects to local aspects. Thus the report presents details of personnel and logistics for forest control in the study area. It also looks into the institutional set up of the country's forest sector and its impact on forest control, and examines law enforcement as a major means of forest control. Then the other control mechanisms are evaluated. The investigation on these issues showed that, currently, each individual forest staff controls a very huge area beyond his logistical capacity hence is unable to control it effectively. For example, during the period 1989 through 1994, unarrested cases accounted for 79 percent of all illegal pitsawing activities in the Nguru South Forest Reserve. Moreover, the country's institutional set up characterized by different chains of command to manage the same resource, the forest, creates implementation problems particularly with regard to legal aspects. A complex process to revise laws and regulations, royalties and property rights and policies is another institutional problem complicating forest control. The report points to the limitations of the existing legislation in practice and its means of implementation such as licensing, royalties and property rights. It was found that legislation alone has failed to effectively control the use of the forest due to difficulty of law enforcement. Without underrating the role of law enforcement, other approaches to forest control such as community participation in forest management and buffer zone management are essential recipes to a successful forest control policy. This underlines the role of economic incentives to elicit forest protection based on benefits to the local community.

The report also dwells on buffer zones as a means of forest control. The type, status and extent of buffer zone around the rainforest in the Nguru mountains is analyzed focusing on how intensive landuse in the area, earlier designated as buffer zone, has degraded it such that human impact is spilling over into the core rainforest. It was found that neglecting the role of the buffer zone by forest authorities is one reason for the dismal contribution of this mechanism to the protection of the rainforest. It is concluded that unrealistic laws, limited means and search for forest products, have greatly contributed to violation of forest rules and poor protection leading to forest degradation. Patrolling by forest guards and imposition of penalties through legislation enforcement has not been effective due to the limitations in human and financial resources. Moreover, the present inefficient law enforcement has created disharmony with the local communities. It has also enhanced the view of a forester as a "policeman" enforcing government imposed restriction on what local people perceive to be their legitimate right to use the forest

resources in their vicinity to earn a living. Under pressure of growing population and unsustainable landuse practices, this has enhanced illegal activities in the rainforest and destructive encroachment. Ambiguous forest borders, neglected role of buffer zones, lack of forest education, high demand for forest products and poverty are among the factors causing forest law violation. Besides improving facilities for the forest staff to enhance forest law enforcement, it is therefore urgent to review forest protection practices and methods in order to devise better approaches to revitalize forest control. Since most of these problems originate from local communities, one clear approach is the involvement of people in forest management and providing them with a good share of benefits through a recognition of village rights to resource use. Community-based conservation must be enhanced by forest education and by establishment of effective buffer zones around the rainforest. The government must augment these measures by a political commitment to change in order to remove institutional barriers to forest protection. Integrating forest management with local, social and economic needs augmented with forest education in the context of the law and removal of institutional barriers, are thus essential for other measures to protect the rainforest to be implemented successfully.

Report number 3.

In developing countries like Tanzania, peasants represent a link between the economy and ecology, and the environmental balance is closely linked to the way peasants manage and utilize resources. In the Nguru mountains, like in many parts of Tanzania, farming is the main economic activity. As a major landuse it accounts for most of the forest and land degradation as well as deforestation pressure. Due to the strong link between farming and ecological degradation, this report presents an analysis of agriculture and forest relations at micro-level based on welfare theory, household economics and mathematical programming as tools for understanding how and why peasant farmers through their farming practices, influence forests. The broad objective of this report is to analyze farming systems in relation to sustainable management of the tropical rainforest in the Nguru mountains. The main idea is to investigate how changes in agricultural practices can influence deforestation. The more specific objectives are to: (a) carry out a comprehensive survey of resource availability, utilization and productivity in Mhonda village; (b) investigate the effect of changes in resource uses on deforestation; (c) use deterministic and stochastic linear and non-linear programming models for analyzing: (i) optimal returns and allocation of land under the existing landuse practices by maximizing total net income while meeting subsistence needs of the household and; (ii) the effects of minimization of risk and labour use variations on landuse pattern, total net income, subsistence consumption and deforestation; (iii) to conduct sensitivity analysis on the impact of changes in population growth, land area, crop prices and total working capital on total net income, household consumption and deforestation; (iv) analyze the possibilities for developing efficient landuse plans at household level in order to satisfy household needs and prevent ecological degradation and deforestation; (v) to evaluate various policy measures and give recommendations for implementation of efficient landuse plans.

The study has its basis in microeconomic and welfare theory, theory of household economy and mathematical programming, but some macroeconomic, anthropological and sociological

perspectives are also incorporated. Data were collected in Mhonda village in the Nguru mountains using interviews (questionnaire survey), field observations, and secondary sources. For the purpose of formulating efficient farm plans at household farm level, a multi-objective programming farm planning model using Compromise Programming was developed to evaluate the productivity and efficiency of agricultural resource use in a household. This model was applied to maximize income, minimize risk (income variation), and minimize labour use variation simultaneously, subject to a number of constraints. The overriding assumption used was that farmers aim at maximizing income, minimizing risk in production and minimizing seasonal labour use variation over the year, since peasant farmer's operations are influenced in different ways by the desire for more income to meet basic needs, risk aversion and drudgery aversion. Based on the farmer's responses, weights given for the three objectives were: 1 each for maximization of income and minimization of risk and 0.1 for minimization of labour use variation. The model included all the important agricultural activities (mainly crop production), fertilizers and other input purchase, and consumption, with possibilities for a farmer to borrow working capital. The working capital consisted of cash used for purchase of agricultural inputs such as seeds, tools, fertilizer and chemicals. The number of days in a month available for farming activities excluded prayer days, holidays and rainy-days when farmers normally do not do much farmwork. Furthermore, it was assumed that each member of the household spent the same length of time on the farm each day. The objective function for maximization of income used farmer's gross margins as coefficients. The stochastic variables, risk and labour use variation, which formed the other two objective functions, were used in quadratic form. The risk elements considered in the objective function for minimization of risk are those which manifest in the objective function as variation in gross margins for individual crop enterprises. These risk elements are crop yield and price. Since risk is measured by the variance of total returns, the reduction in yields following several years cropping on the same field was modelled. The objective function for minimization of labour use variation used monthly labour use data which manifest in the objective function as variation in labour use for various months in a year. In the labour constraints, only peak months were used as constraints because it is during such months that labour could be limiting. Other constraints were developed for various resources identified as being restrictive to the household farming activities.

The results of the resource assessment and micro-economic analysis showed that under current farming practices, factors of production are limiting in supply and must be used optimally. These are land, labour and capital. The current farming practice is that an average household owns about 2.5 ha of farmland on which are grown 18 crop enterprises (i.e. production mix) under three cropping systems. These cropping systems are monoculture cropping (0.9 ha or 36 percent), mixed cropping (1.2 ha or 48 percent) and multiple cropping (0.4 ha or 16 percent). Monoculture cropping involves growing a single crop on a piece of land and is practiced for maize, beans, cassava, rice, sorghum and vegetables. Mixed cropping involves growing together a variety of crops on the same piece of land and is practiced by mixing maize and beans; maize and sorghum; cassava and beans; maize, beans, cassava and sorghum; banana and cassava; fruit trees and cassava and a mixture of minor crops such as peas and groundnuts. Multiple cropping involves growing two or more crops consecutively on the same piece of land and is practiced by growing maize and beans followed by beans during long rains.

The average household size for the surveyed sample was 7 persons. However, only 3.9 adult equivalents were calculated as available for farm work per household. Thus under the existing farming practices, the average household in Mhonda village depends on about 2.5 ha of farmland and about 3.9 adult equivalents of labour to support about 5 consumption units. This means that, the dependency ratio or the worker/consumer ratio, using aggregated labour and aggregated consumer units is 0.8. Thus, for every adult-equivalent (ME) there are 1.3 consumption units to support. This poses a dependency burden on the already impoverished households in Mhonda village. Based on FAO/WHO 1973 standards, one consumption unit requires 2600 kilocalories per day and 60 g protein per day. A consumption unit was computed using the standard WHO weights of 0.5 for children below 11 years, 0.75 for children 11-16 years and 1.0 for all other age categories. Aggregation of household labour stock in man-equivalents (ME) was done by analyzing sex and age composition based on a scheme of coefficients in which, the weights are 1 for adult male and female 18 years and over, 0.5 for males and females 8-11 years, and 0.3 for males and females 8-11 years. Analysis of total working capital showed that it was limiting because farmers make negligible savings, exacerbated by unreliable access to credit. The household cash balance at the start of a year was found to be T.Shs. 2500. Lack of capital limits the extent to which land and labour are utilized.

The base run for mathematical programming involved a static model (i.e. does not include changes in yields over time due to increase in farm area and also does not include changes in yields over time when fields are put under various crops for several seasons) whose aim was to maximize income from a household farm while meeting consumption needs, minimize risk and minimize labour use variation under given resource constraints. Population was then introduced in subsequent model runs as a dynamic factor in order to determine the effect of population growth on household food yield and consumption, income and land demand, and to elucidate deforestation pressure caused by population growth. The purpose of this analysis was to show the level of sustainability of the existing farming systems under the conditions of population growth. Since there is always a possibility for change on the values of some key variables (on account of risk), a sensitivity analysis was done, first on farm-gate (producer) price changes with the aim of exploring the consequences of a particular pricing policy and how the peasant household responds to such price changes, in relation to deforestation pressure. Sensitivity analysis was also carried out to determine the effect of changes in the land area constraint, particularly the effect of new land acquisition through forest clearing by encroachment. The effect of changes in total working capital on the use of resources and deforestation was also analyzed.

Model runs showed that, by optimizing a single objective, their conflicting nature became evident. For example, a minimum level of risk was attained with an allowance of high labour use variation and reduced income. Similarly a highest income was only possible when labour use variation was high. In light of the conflicting nature of farmer's objectives, a trade-off has to be made by compromising them using Compromise Programming. The first step in Compromise Programming involved establishing a pay-off matrix for L_1 , L_2 and L_∞ metrics. In this context, the metrics L_1 , L_2 and L_∞ refer to the distance (deviations or degree of closeness) between the best compromise solution and its "ideal value". These distances are used for generating the best compromise set of solutions. The aim is to make this distance as small as possible. When L_1

metric is used the total deviations are minimized, and when L_{∞} metric is used the maximum of individual deviations is minimized. The L_2 metric is the intermediate. The entire best compromise set or solutions lie between L_1 and L_{∞} metrics which characterize the bounds of the compromise set. The "ideal value" was obtained from the pay-off matrix. The entries in the pay-off matrix were obtained by solving a series of single-objective Linear Programming formulations where each objective was optimized in turn. For every solution so obtained, the values of the remaining objectives of the problem were worked out as associated with that solution. The elements of the main diagonal in the pay-off matrix represented the "ideal point" which had optimum values for the different objectives as coordinates. Since objectives were in conflict, the "ideal point" was infeasible and therefore a compromise between the objectives had to be established. Based on Compromise Programming, the efficient solutions or feasible solutions closest to the "ideal point" were chosen or defined as best compromise or as the optimum, depending on the measure of deviation (i.e. L_1 , L_2 or L_{∞}). The ideal point was therefore useful only in serving as a standard against which all the compromise solutions were evaluated.

By comparing compromise farm plans generated by the model against the existing farm plan, the differences between them were gleaned. In this context, the existing farm plan refers to what farmers are actually doing (a real farming situation) under the current farming practice of 18 crop enterprises, under 3 cropping systems using an average of 2.5 ha per household. This existing farm plan gave an annual maximum household income of T.Shs. 233,750, minimum risk of T.Shs. 168,321 and minimum labour use variation of 3.5 ME-mandays. Compared to the existing farm plan, all compromise farm plans were superior in terms of income since the latter gave higher income than the former. The percentage increase in income of the compromise farm plans compared to the existing farm plan were 21, 21, and 14 corresponding to L_1 , L_2 and L_{∞} metrics respectively. Although the increase in income depends on how realistic are the estimates of yield and risk, yet there seems to be a possibility of gaining through allocative efficiency if the farmer adopts any of the compromise farm plans to replace the existing farm plan. More gains would probably be realized through technical efficiency if farming technology was improved. As expected, the compromise farm plans were superior to the existing farm plan in terms of levels of risk expressed as a percentage of income. For the existing farm plan it was 72 percent whereas for the compromise farm plans corresponding to the three metrics, the percentages were 69, 69 and 66 respectively. However, the absolute level of risk (T.Shs. 168321) for the existing farm plan was lower compared to the compromise farm plans for which the risk levels were T.Shs. 195590, 195590 and 175968 corresponding to L_1 , L_2 and L_{∞} metrics respectively. This lower level of risk in the existing farm plan compared to the compromise farm plans portrays the real life experience that peasant farmers are risk averters. It also suggests that probably more weight is given to risk minimization in the real farming situation than was given in the model. However, farmers will pursue farming even when it is risky, for the sake of meeting subsistence needs and when the expected income increases. Since they rely solely on farming activities for subsistence and cash income, they have limited options. In most cases they tend to be more concerned with the management or avoidance of risk. The level of labour use variation reflects the fact that labour use over the year is not uniform due to the skewed labour demand by seasons of the year.

Regarding land allocation, an average household cultivates all available household land during

the year to meet its subsistence needs. This may imply that land is inadequate and hence highly valuable. This limits possibilities for an average household to allow some land to lie fallow, and have negative impact on soil fertility and crop productivity. In the absence of capital to buy fertilizer, farmers try to compensate decline in crop productivity by acquiring fresh land through forest encroachment thus increasing the deforestation pressure. The compromise farm plans generated by the model were superior to the existing farm plan in terms of fertilizer use and therefore more appealing in terms of maintenance of soil fertility. Nitrogen fertilizer use increased by 84, 84, and 113 percent whereas Phosphorus fertilizer use increased by 8, 8 and 32 percent for the compromise farm plans corresponding to the three metrics respectively. This may reduce the farmer's desire to compensate decline in crop productivity by forest encroachment. Probably farmers do not use as much fertilizer because the household cash is needed for other items particularly consumption. The compromise farm plans gave a narrow crop production mix (enterprises) compared to the existing farm plan. While there are 18 crop production enterprises in the existing farm plan, they were reduced to 11, 11 and 10 in the three compromise farm plans corresponding to the three metrics. The reason is that only profitable crop enterprises were selected in the compromise farm plans based on the assumptions of the model. By selecting only those enterprises which are profitable, the model ensures that higher total net income is realized than in the existing farm plan. This would be beneficial to the farmer. The relatively narrow diversity of crop production enterprises for the compromise farm plans compared to the existing farm plan implies that to maximize income, farmers may consider to specialize in profitable enterprises. The crop enterprises eliminated in the model solutions were mainly under monoculture cropping system which seems uncompetitive for risk aversion under peasant farming systems. In the model, the land allocated to the main staples should be expanded at the expense of others. Under the existing conditions of land scarcity, model solutions suggest that producing mixed crops seems to be more competitive than monocropping for generating income, diversifying to meet subsistence needs, risk aversion and for flexibility. The compromise farm plans were able to meet recommended minimum consumption needs for each crop with surplus for sale to earn cash income. They also meet food variety requirements consistent with current consumption patterns in the study area. Generally, these plans were superior to the existing farm plan in terms of food yield. Based on these results farmers could maximize welfare by adopting compromise farm plans to replace the existing farm plan. One reason for the difference between the existing farm plan and compromise farm plans could be some risk factors not included in the model.

The compromise farm plans further suggest that the realistic labour demand is lower compared to the existing farm plan. Thus the apparent labour shortage in constraining months might be due to labour misallocation or misuse. Farm expansion and increased off-farm activities are possible ways to engage free labour into productive work. In the compromise farm plans, some labour use redistribution took place in the process of evening-out labour use variation. Capital was a limiting factor and affected the way labour and land are used. Capital limitation would increase even further if farming technology was improved and if savings remained low and institutional credit not forthcoming. The effect of changes of total working capital was analyzed. The first scenario assumed that there was no land clearing and working capital was unrestricted. The second scenario assumed that land clearing was allowed under restricted working capital condition. The

third scenario assumed that land clearing was allowed under unrestricted working capital condition. When capital supply was increased with no possibility for land clearing, the effect was to increase the use of farm inputs mainly fertilizer, to increase food supply and altering land allocation considerably. However, with land clearing allowed, increase in capital supply resulted in expansion of farmland through forest clearing hence promoting deforestation pressure. Thus with land clearing allowed, increased capital supply would increase the household's ability to mobilize labour and acquire farming implements essential for land clearing. From results of the model, the land cleared as a result of increasing capital supply equals a deforestation rate of 3.9 percent of the forest area per year when land clearing is allowed under restricted working capital condition, all other factors being equal. It also equals a deforestation rate of 7.3 percent of the forest area per year when land clearing is allowed under unrestricted working capital condition, all other factors being equal. Due to scarcity of land for clearing, it could be more rational for the farmer to use additional capital supply for improving the existing farm than engaging in forest encroachment. Based on deforestation rate changes as a result of increasing working capital and under the assumptions of the model, the elasticity of deforestation rate in the Nguru mountains was calculated to be 1.3 which implies that, if working capital changed by one percent, deforestation rate would change by 1.3 percent within the same period. When the assumption regarding availability of institutional loan was taken out, a lower net income was obtained than in the farm plan incorporating this assumption. Moreover, area of cultivated farmland declined by 0.4 ha per household per year because 2.1 ha/household per year were cultivated instead of 2.5 ha per household per year. The effect is to reduce deforestation pressure by forest encroachment. However, even this relatively smaller area cultivated would most likely be poorly managed due to lack of cash, thus enhancing soil degradation.

The effect of population pressure was also analyzed. The main assumption was that population growth causes deforestation and this being the consequence of derived demand for household food and cash income. Under conditions of poor farming practices and limited arable land it encourages land clearing in order to acquire fresh land or expand farmland. Two scenarios were analyzed. The first scenario assumed a population growth rate of 2.6 percent per annum, over a period of 35 years while holding household cash income and food consumption from own farm non-declining. The second scenario assumed a population growth rate of 3.5 percent per annum, over a period of 35 years while holding household cash income and food consumption from own farm non-declining. It was found that at the existing level of farming technology in Mhonda village, population growth will increase deforestation pressure unless farming is improved. Over a 35 year period, at 2.6 percent annual population growth rate, the deforestation rate is 0.2 percent per year; and at 3.5 percent annual population growth rate, deforestation rate is 0.3 percent per year. The countrywide average deforestation rate for all forest types is at present 0.3 percent per year based on the present average Tanzania's population growth rate of 2.8 percent per year. Based on deforestation rate changes as population increases and under the assumptions of the model, the elasticity of deforestation rate in the Nguru mountains was calculated to be 1.9 which implies that, if population changed by one percent, deforestation rate would change by 1.9 percent within the same period. Further analysis showed that, given the available land resources, the existing farming practices can sustain the present annual population growth rate of 2.6 percent for a duration of between 10 and 15 years. At higher population growth rates the duration is even

more restricted. In a long-term perspective, existing farming systems in Mhonda village are unsustainable because the maximum period of between 10 and 15 years is too short to support even one human generation. There is urgent need to improve farming technology to raise crop yields to higher levels. There is also a need to introduce non-farm activities to improve economic welfare of the farmers. At present, induced technological improvement has not taken place, probably because critical population pressure has not been reached and what we can refer to as "resources for last resort" are still within reach to enable people to survive.

Farmer's risk aversion behaviour was analyzed by assigning different subjective weights to the three objectives of the model in five scenarios. In the first scenario, equal weights were assigned to the three objectives. In the second scenario, more weight was put on maximization of income. In the third scenario, more weight was put on minimization of risk. In the fourth scenario, more weight was put on minimization of labour use variation. In the fifth scenario, more weight was put on risk and labour use variation minimization objectives than on the objective for maximization of income. The results showed that farmer's risk aversion behaviour is closely linked to farmland expansion which causes deforestation pressure. When farmers perceive risks in farming to increase, they tend to reduce farm area and when they perceive risks to decrease, they tend to expand farms by land clearing thus accelerating deforestation pressure, all other factors being equal. A cost-benefit analysis of farm expansion by clearing new land as a result of population growth, showed that it is most profitable on small farms because these can arrive at break-even point faster than large farms since they have lower operating costs and do not suffer from labour shortage as large farms. Households with small farms were the ones found to be more concerned with clearing new land to expand their holdings. This sounds logical because these are essentially marginalized households. However, their craving for farm expansion is sometimes curtailed by lack of land for clearing, lack of money for buying implements essential for land clearing, or labour shortage. Population growth was also found to cause decline in total net income hence per capita income overtime due to increased food demand leaving less of output for sale. Since total net income has a direct bearing on the level of household poverty and purchasing power, it affects the household's consumption of market goods, level of savings, ability to invest, and hence standard of living. This promotes poor landuse practices which increase deforestation pressure.

The effect of increasing producer prices was analyzed by model runs with consecutive small increases on crop producer price. The results showed that increase in crop producer prices caused household total net income to rise, promoting savings and investment in farming. In the presence of land for farm expansion it could increase deforestation pressure. Based on deforestation rate changes as a result of increasing crop producer prices and under the assumptions of the model, the elasticity of deforestation rate in the Nguru mountains was calculated to be 0.7 which implies that, if all crop producer prices were changed by one percent, deforestation rate would change by 0.7 percent within the same period. The effect of increasing fertilizer price was analyzed by model runs with small increases in fertilizer price, mainly nitrogen and phosphorus. The results showed that increasing fertilizer prices reduced total net income which further impoverishes farmers and promotes deforestation pressure. Profitability of farming is governed by, among other things, the cost of inputs and producer prices. When farmers earn profit chances are that they will

improve their living conditions and reduce deforestation pressure.

Regarding the multi-objective compromise programming model developed in this study it may be a useful tool in technology evaluation. It permits judgement of technologies in a more holistic framework than simple analysis. It may be useful in developing efficient farm plans and developing agricultural policies within given socio-economic conditions. It can simultaneously handle and weigh important constraints against each other for typical model households and using computer technology, computations can be easily and quickly done. The model may serve as a useful decision support system with positive impact on possibilities for mitigating deforestation. It provides an efficient way of reproducing the farm reality and its responses to different external factors that affect the farmer's decision making process. Since farmers usually have conflicting objectives, the model illustrates that, there is a cost in emphasizing one objective in relation to others. The model, provides possibility to quantify trade-offs between objectives. Nonetheless, this model still needs calibration with more accurate coefficients, needs updating and should be tested for its predictive power under various conditions. Inclusion of other stochastic variables may also be contemplated. There should also be a balance between complexity of the model and its operationality, because efforts to extend the model or to modify it to come much closer to reality, may sacrifice its applicability. A balance must be met to ensure best or optimal decisions while recognizing that such decisions may not be the "best" for every particular state of nature, but rather may be robust across a wide range of conditions. The common point of view that models cannot replace the analytical power of the human being from which they originate, still holds true. Thus the model developed here, should only be used as a means to assist in decision making, because it can handle many variables in a consistent manner.

Among the shortcomings of the model are that the risk factors included, only relates to the crop yields and prices, the sources of risk that are manifest in the objective function as variability in gross margins for individual crop enterprises. This emphasis is due to the historical importance of both yield and price in agriculture, but does not mean that other sources of risk are unimportant. Other risks like natural hazards, changing demand, social uncertainty and changing government policies which were not modelled, often affect households as risks in production, costs, resource usage and resource availability. The model also focused on accommodating risk in the objective function coefficients. It did not deal with risks that appear in the formulation as right hand side (RHS) parameters. For instance, by defining the programming model in particular ways, uncertainty in water supplies or field time may appear as RHS parameters. Other model weaknesses may be caused by data paucity (i.e. limitation) in some variables and the fact that the assumptions made may sometimes be unrealistic. These notwithstanding, the model and experience gained in building and using it are important in improving the understanding of the problems of landuse planning and hence positively contribute to the decision making process to improve resource management and reduce deforestation pressure.

General concluding remarks

It seems that ecological and socio-economic factors have played an important role in shaping the existing landuse practices in the Nguru mountains. The conflict between agriculture and forestry,

the two major landuses, has contributed most to the prevailing landuse problems. Given the existing landuse problems and constraints to farming, deforestation pressure and degradation will continue to prevail. Landuse problems are a consequence of many interrelated factors acting as local driving forces or originating from a broader dimension beyond local boundaries. However, population growth, land scarcity, increased domestic demand for goods, poverty, lack of knowledge, market and government failures, risk and uncertainty and conflicting objectives between land users seem to be the main driving forces behind landuse problems causing deforestation.

The deforestation pressure caused by landuse problems have been more severe on lowland rainforests, where high rates of rainforest conversion to agriculture and other landuses are more pronounced. Forest protection by law enforcement have not produced effective results to prevent the impact of landuse problems on the rainforest. Poor household economy due to low agricultural productivity seem to contribute greatly to these problems. The analysis of household resource utilization have shown that most factors of production are limiting and must be used optimally. Mixed cropping patterns seem to be most profitable in the household economy. There are also good prospects for improving farmer's performance by farm planning at the household farm level to optimize resource allocation under multiple objectives. This would improve standard of living and reduce deforestation pressure. Under the model assumptions specified, such a policy favours the concentration on mixed cropping patterns in which legume crops increase soil fertility and diversified crops avert risk. This cropping pattern seems environmentally sound and also may reduce pressure for family labour during peak months. Rising fertilizer and other input prices while offering low producer prices, would continue to reduce farmer's net incomes thus negatively affecting forest lands. Farmers would try to compensate a decline in crop productivity caused by lack of fertilizer through land expansion and adopting inappropriate landuse practices.

Since the existing farming practices in the Nguru mountains can sustain the present population growth rate of 2.6 percent per year for a duration of 10 to 15 years, there is an urgent need to improve farming technology if long-term sustainability is to be contemplated. A careful and equitable economic policy, based on an understanding of the incentive structure of the peasant farmers, is essential to foster more sustainable landuse practices and wise use of forest resources. Improving producer prices and credit facilities to farmers are important measures to motivate them. The government should also remove institutional impediments to agriculture and forestry development like poor infrastructure, lack of markets for crops and lack of inputs such as seeds and fertilizers. Revitalizing agroforestry farming system may help in conserving soil and providing soil fertility. Improving the supply of substitutes to forest products and introducing low cost, energy-efficient stoves augmented by vigorous extension education may reduce excessive exploitation of forest resources. More emphasis on family planning education is also needed for birth control to reduce population growth.

However, improving the living conditions of the people remains the key issue to alleviate landuse problems that enhance deforestation pressure. One way to achieve this is by increasing income from activities outside agriculture to supplement agricultural income. Off-farm opportunities for generating extra income include: casual employment; small-scale enterprises from nontimber

forest products such as basket and mat weaving; services such as shopkeeping, transport on bicycles and tourism. At present off-farm activities contribute about 20 percent of household income. Of these, timber and local crafts 13 percent, petty business 5 percent, remittances 1 percent, and casual employment 1 percent. Timber seems to dominate as the main source of revenue from the tropical rainforest. Nontimber benefits of the tropical rainforest in the Nguru mountains have not been fully utilized for economic benefit. The species richness of the tropical rainforest give possibility for nontimber commercial uses. At present local communities make limited use of nontimber benefits from the tropical rainforest to meet domestic needs such as firewood, medicine and food security in times of food shortage. Improvements in yield and availability, collection techniques, processing of collected material, use, storage and marketing of nontimber forest products would be a positive step in improving the household economy.

**RAINFOREST DEGRADATION AND LANDUSE IN THE NGURU MOUNTAINS,
TANZANIA: ANALYSIS OF SOCIO-ECONOMIC AND ECOLOGICAL ASPECTS**

REPORT NUMBER 1

ABSTRACT

The purpose of this report is to identify the main landuse and landuse problems with reference to agriculture and forestry in the Nguru mountains, and the main factors causing these problems, and analyze ways to reduce them in order to prevent forest degradation and deforestation. Based on data collected in villages in the Nguru mountains using interviews, field observations, and secondary sources it seems that ecological and socio-economic factors have played an important role in shaping the existing landuse practices, landuse problems and factors causing landuse problems in the Nguru mountains. The major landuses are agriculture and forestry. The agriculture is dependent on rainfall, growing mainly subsistence food crops using traditional farming practices. Forestry is for water conservation but also supplies local communities with both timber and nontimber forest products. Relative to other landuses such as settlements and grazing, agriculture and forestry have contributed most to the prevailing landuse conflicts in the Nguru mountains. The main landuse problems in the Nguru mountains are: deforestation pressure through encroachment for agriculture and settlements, forest degradation through excessive forest product exploitation, frequent and uncontrolled bush fires, land degradation and soil erosion, declining crop harvests, squatters inside the Forest Reserve, farming in the buffer zone around the rainforest and non-adherence to forest control measures. The impact of these landuse problems on the rainforest have been more severe on lowland rainforests where high rates of rainforest conversion to agriculture and other landuses were observed. These landuse problems are a consequence of many interrelated factors acting as local agents or beyond local boundaries. These factors are caused by complex processes resulting from human social dynamics. From survey results in the area these factors range from social, economic, cultural and political forces which are related to each other in multilineal causal chains. The main ones are: growing population, land scarcity, search for market goods, increased domestic demand for food and forest products, poverty, lack of knowledge, lack of an effective extension service, market failures such as breakdown of traditional management systems due to commercialization of demand for resources, government failures such as inefficient government policies, risks and uncertainty in farming (pests, diseases and vagaries of climate) insecure land rights under customary land tenure system, traditional or cultural barriers, conflicting objectives between land users, failure to control protected areas such as Forest Reserves and decline in forest product supply and lack of income from outside agriculture and forestry. It seems the government has not been able to control landuse problems through policy measures or coercion. Also the market has not been able to do so, due to its failure to provide negative feedback loops to check landuse problems. Widespread market and government failures largely account for this situation since, they provide incentive for poor landuse practices. Rural poverty and efforts to adapt to economic hardships at the local level have a significant influence on landuse problems. Vaguely defined, unequitable and uncertain land tenure conditions, lack of knowledge and traditional barriers have added a complicating dimension to landuse problems. The poor local people, the direct agents of degradation and deforestation pressure, have been made to rely on unreliable access to credit markets due to the absence of guarantees (collateral), caused by lack or uncertainty of tenure. The effect has been to increase landuse problems. Since the welfare and survival of the local people in the Nguru mountains, are inextricably linked with agriculture and the environment, they must improve current landuse practices, in order to come to terms with the reality of resource

limitation and carrying capacity of their ecosystem. Wise management of land and forest resources requires appropriate landuse practices, to alleviate landuse problems in order to improve the standard of living and preserve the biological systems, especially the tropical rainforest upon which they depend. The strategy recommended requires landuse planning for efficient use of resources and integrated planning to harmonize conflict between land uses. Other measures include family planning to control population growth, education to enhance change of attitude on resource use, by overcoming communication breakdown between resources users and protectors through direct dialogue and community involvement, giving some specific rights to property in reserved forests, and benefits to villagers to meet their needs while protecting the resources, improving traditional landuse systems and traditional knowledge, incorporating agroforestry in farming systems, removal of institutional barriers to wise landuse by government through appropriate policy changes, and improvement of rainforest management methods to enhance forest protection.

Key words: Degradation, deforestation, property rights, rainforest, landuse planning, socio-economic analysis, population growth, income, agriculture, forestry, peasants.

ACKNOWLEDGEMENT

This report has been possible due to the invaluable help, advice, criticism and information from various individuals and institutions. I am deeply indebted to all of them. However, my special gratitude is extended to my supervisor Prof. Dr. Birger Solberg of the Norwegian Forestry Research Institute (NISK) for his helpful criticism, suggestions and guidance right from the time I started this work to its completion. Dr. A.R.S. Kaoneka and Prof. Aku O'Kting'ati both at the Department of Forest Economics, Sokoine University of Agriculture (SUA), read and commented on the preliminary draft of this report. Peasant farmers in Mhonda village and other villages in the Nguru mountains, the pitsawyers, local leaders and local Government agents devoted their time to respond to interviews. For special mention are: Mr. F.N. Kabelwa, Village Chairman, Mhonda; Mr. P.M. Msemwa, Village Councillor, Mhonda; Mr. B.A. Semndi, Assistant Community Development Officer, Mhonda Ward; Mr. Morris S. Mtita, Ward Executive Secretary, Mhonda; and Mr. P.S. Chabembe Member of the Secretariat of Mhonda Village Primary Cooperative Society.

Government offices in Morogoro Region and the Catchment Forest Project provided very valuable assistance. For special mention are: Mr. R. Njana, Morogoro Regional Catchment Forest Officer; Mr. Tore Torstad, Norwegian Volunteer, Advisor to the Morogoro Region Catchment Forest Project and Mr. Kalebi, Morogoro District Catchment Forest Officer. Others (with the person's position and office at the time of contact with the author) are: Mr. Daniel Selapio, Forester, Mvomero Division; Mr. W. Mlay, Catchment Forester, Mvomero Division; Mr. F.P. Matenge Ward Forester, Kibati; Mr. J. Michael Forester, Mkindo Ward; Mr. B. Halfani, Forester, Hembeti Ward; Mr. S. Mhagama, Regional Natural Resources Officer, Morogoro; Mr. J.U. Maanga, District Forest Officer, Morogoro and Mr. Noah, Regional Forest Officer, Morogoro. Last but not least, are Messrs. A.S. Kigona, E.F. Mazengo, C.O.B.Z. Jamal, D. Mwaikenda, and Mr. Kimu who assisted in conducting the interviews and field observations. Mr. Y.M. Ngaga, a colleague at AUN and at SUA discussed with the author various matters related to this report.

The Norwegian Agency for Development Cooperation (NORAD), sponsored the study. The Department of Forest Sciences at AUN accepted me as a Dr. Scient. student and provided logistical support. Department of Forest Economics at SUA provided logistical support during field work in Tanzania. The authorities at Sokoine University of Agriculture granted study leave to pursue my PhD studies.

To all these individuals and institutions, my best thanks.

TABLE OF CONTENTS

TITLE	(i)
ABSTRACT	(ii)
ACKNOWLEDGEMENT	(iv)
TABLE OF CONTENTS	(v)
LIST OF TABLES	(ix)
LIST OF FIGURES	(x)
LIST OF APPENDICES	(xi)
LIST OF ACRONYMS	(xii)
METRIC UNITS	(xiii)
1.0 INTRODUCTION	1
1.1 Rainforests: distribution and importance in Tanzania	1
1.2 Human impact in and around the tropical rainforests in Tanzania	2
1.3 Forest and land degradation in the Nguru mountains	4
1.4 Objectives of the study	6
1.5 Study outline and main limitations	8
1.5.1 Study outline	8
1.5.2 Main study limitations	8
2.0 LITERATURE AND THEORETICAL CONCEPTS ON SOCIO-ECONOMIC ASPECTS OF FOREST RESOURCE MANAGEMENT, UTILIZATION, DEGRADATION AND DEFORESTATION	10
2.1 Review of Peasant farming and landuse	10
2.2 Broad perspective of landuse problems	11
2.3 Sustained Management and optimal utilization of tropical rainforests	14
2.4 Property rights and forest resource utilization	15
2.4.1 Context of property rights	15
2.4.2 Property rights and revenue collection from resource users	16
2.4.3 Property rights and sustainable forest management	17
2.4.4 "Open access" resource use, "the tragedy of the commons" and property rights	19
2.4.5 Property rights when externalities exist and effect on forest management	21
2.5 Review of forest degradation and deforestation	22
2.5.1 Context of forest degradation and deforestation	22
2.5.2 The problem of deforestation and degradation	24
2.5.3 Theoretical paradigms of development to explain factors underlying deforestation	25
2.5.4 Theory of deforestation	25
2.5.5 The Gap Theory and estimation of deforestation dimensions and rates	27
2.5.6 Estimates of deforestation and landuse change data	28

2.5.7	Socio-economic and landuse-related causes of deforestation in developing countries	35
2.5.7.1	System causality of deforestation	35
2.5.7.2	Direct causes	36
	The decisive indirect role of population growth	36
	Schools of thought on role of population on tropical deforestation	36
2.5.8	Consequences of deforestation in developing countries	37
2.5.9	Efforts to arrest deforestation in developing countries	37
2.5.9.1	Current Policy: Need for change to foster integrity and stability of forest ecosystems	37
2.5.10	Review of deforestation and degradation: The case of Tanzania	38
2.5.10.1	Introductory background	38
2.5.10.2	Studies and trends of degradation and deforestation in Tanzania	38
2.5.10.3	Causes of degradation and deforestation in Tanzania	40
	Population growth	40
	Population distribution and the influence of urbanization	40
	Population distribution and the influence of villagization	40
	Poverty aspect	40
	Policy problems	41
2.5.10.4	Immediate causes of degradation and deforestation in Tanzania	41
	Annexing forest for agriculture and human settlement	41
	Impact of logging	41
	Uncontrolled burning and grazing	42
	Woodfuel requirements	42
2.5.10.5	Effects of deforestation	42
	Gene erosion	42
	Water conservation and management	42
	Influence on microclimate	43
	Socio-economic aspects	43
2.5.10.6	Efforts in arresting deforestation and forest degradation	43
	Poverty alleviation	43
	Soil conservation efforts	43
	Village afforestation	44
	Conservation and management of natural forests and woodlands	44
	Institutional control of the forests	44
3.0	THE STUDY METHODOLOGY	45
3.1	The study area	45
3.1.1	Origin, location and access of the Nguru mountains	45
3.2	Data types and collection methods	47
3.2.1	The household survey	47
3.2.2	Field observations	48
3.2.3	Data from secondary sources	49

3.2.4	Data analysis	50
4.0	RESULTS AND DISCUSSIONS	51
4.1	Some ecological factors which have shaped landuse practices in the Nguru mountains	51
4.1.1	Influence of geology and soil	51
4.1.2	Influence of topography	51
4.1.3	Influence of climate	52
4.1.4	Influence of vegetation aspects	53
4.1.4.1	Lowland woody vegetation	55
	Lowland rainforest	55
	Dry semi-evergreen forest	55
	Miombo woodlands	55
4.1.4.2	Submontane rainforests	55
4.1.4.3	Evergreen montane rainforests	56
	Mossy montane rainforest	56
	Montane rainforests	56
	Mesic montane evergreen forest	56
	Elfin forests and ericaceous heaths	56
4.1.4.4	Bamboo forests and thickets	56
4.1.4.5	Edaphic communities	57
4.1.4.6	Cultivated fields, wooded grassland and secondary forest	57
4.1.4.7	Influence of fauna ecology	58
4.2	Socio-economic aspects of landuse in the Nguru mountains	58
4.2.1	Some social anthropology aspects	58
4.2.2	Human population dynamics	60
4.2.3	Income opportunities	61
4.2.4	Landuse and tenure rights	62
4.2.5	Agricultural landuses	64
4.2.5.1	Farming systems	64
4.2.5.2	Crops and cropping systems	68
4.2.6	Forestry landuses	71
4.2.6.1	The Catchment Forest and watershed management	72
4.2.6.2	Silviculture in the Catchment Forest	74
4.2.6.3	Role of the Morogoro Region Catchment Forest Project (CFP) in sustainable management of the tropical rainforest in the Nguru mountains	75
	History of catchment forests in Tanzania	75
	Management objectives and strategy of the Catchment Forest Project	75
	CFP implementation	76
4.2.6.4	The Nguru South Forest Reserve as a case project for the CFP activities	77
	Management activities under the CFP	77
	Community participation in forest management	79
	Rights of villagers in the Forest Reserve under Community Participation Programme	80

4.2.7	Pastoralism as a landuse in the Nguru mountains	81
4.3	Landuse problems in the nguru mountains	81
4.3.1	Nature of landuse problems in the Nguru mountains	81
4.3.2	Main landuse problems in the Nguru mountains	83
4.3.2.1	Encroachment of Forest Reserves for agricultural expansion	83
4.3.2.2	Deforestation pressure, forest and land degradation	84
4.3.2.3	Problems due to sawmilling	88
4.3.2.4	Problems due to pitsawing	88
4.3.2.5	Problems due to dependency of local communities on the tropical rainforest	94
	Problems due to wood collected for local consumption	95
	Problems due to collection of other non-timber forest products	99
4.3.2.6	Problems due to fire hazards	99
4.3.2.7	Problems due to clearing of forest for cash crop production	102
4.3.2.8	Problems due to shifting cultivation (slash and burn)	102
4.3.2.9	Problems due to squatters inside the Forest Reserve	103
4.3.2.10	Problems caused by farming in the buffer zone	103
4.4	Main factors causing landuse problems in the Nguru mountains	104
4.4.1	Rapidly growing population	106
4.4.2	Land tenure system and insecure land ownership (attenuated property rights)	107
4.4.3	Traditional barriers	110
4.4.4	Different priorities between land users	110
4.4.5	Ignorance and lack of effective extension service	111
4.4.6	Government failures	112
4.4.7	Market failures	114
4.4.8	Poor farming technology and lack of farm inputs	115
4.4.9	Uncertainty due to pests, diseases and vagaries of climate	116
4.4.10	Fragmentation of land and diminishing parcel size	117
4.4.11	Peasant conviction that fertile arable land is in the forest	117
4.4.12	People's concern for the fulfillment of immediate domestic needs	118
5.0 CONCLUSIONS AND RECOMMENDATIONS		119
REFERENCES		122
APPENDICES		132

LIST OF TABLES

Table 1.1.	Patterns of landuse in Tanzania	1
Table 1.2.	Distribution of the forest estate in Tanzania	1
Table 1.3.	Area distribution of Catchment Forest Reserves in Tanzania	3
Table 2.1	Global landuse change 1700-1980	13
Table 2.2	Estimates of forest cover area and deforestation by geographic sub-regions	30
Table 2.3	State of forest inventory in the tropics	30
Table 2.4	Estimates of rates of deforestation in the humid tropics	31
Table 2.5	Forest cover change matrix for the tropical African region	33
Table 2.6	Global land conversions 1977-1987	35
Table 2.7.	Forests of Tanzania by use and legal status	38
Table 4.1.	Summary of monthly meteorological data in the Nguru mountains, average for five stations	53
Table 4.2.	Percentage distribution of population by sex and age groups in the Nguru mountains	61
Table 4.3.	Contribution of various income sources to household income in the Nguru mountains	62
Table 4.4.	Methods for legitimization of land ownership and acquisition of additional land	63
Table 4.5.	Location of farms by altitude and average land slope of land on the farms	64
Table 4.6.	Motives behind cultivation at long distances from homesteads	65
Table 4.7	Responses regarding how long a farmholding has been used continuously	66
Table 4.8.	Responses regarding various reasons for not using fertilizer	67
Table 4.9.	Average present use of fertilizer	67
Table 4.10.	Percentage of households practicing each cropping system and the average size of the household farm under each cropping system	68
Table 4.11	Common trees retained on household farms and farm boundaries with their uses	69
Table 4.12.	Reasons for practicing monoculture cropping system	70
Table 4.13.	Reasons for practicing mixed cropping system	70
Table 4.14.	Risks to farming in the Nguru mountains as identified by farmers	71
Table 4.15.	Forest Reserves in the Nguru mountains	74
Table 4.16.	Pace of boundary resurveying and marking in Nguru South Forest Reserve	78
Table 4.17.	Forest Reserve encroachment for cultivation in Morogoro District for 1989-1993	83
Table 4.18.	Landuse/cover changes in the Mhonda area, Nguru South Forest Reserve	85
Table 4.19.	Proportion covered by each land use class and changes within each class for Mhonda area, Nguru South Forest Reserve, 1949 - 1993	85
Table 4.20.	Percentage of landuse area by altitude converted to (+) or from (-) each landuse between 1949-1993 in Mhonda area, Nguru South Forest Reserve	86

Table 4.21.	Changes of area for two selected landuses inside and outside the Nguru South Forest Reserve in Mhonda area	87
Table 4.22	Percentage changes in area under various landuses at different altitudes for the period 1949-1993 in Mhonda area, the Nguru South Forest Reserve	88
Table 4.23.	Licensed harvesting in Nguru South and Mkindo Forest Reserves during the period 1989-1992	90
Table 4.24.	Illegal harvesting in Nguru South and Mkindo Forest Reserves during the period 1989-1994	91
Table 4.25.	List of pitsawn trees by species and girth range (at breast height) in various felling coupes in the Nguru South Forest Reserve for the period 1989-1994	92
Table 4.26.	Trail survey results showing trails and trail density in selected parts of Nguru South Forest Reserve in Mhonda area	96
Table 4.27.	Results for observation of firewood collectors in Mhonda area, Nguru South Forest Reserve	97
Table 4.28.	Measurement results for firewood bundles in Mhonda area, Nguru South Forest Reserve	98
Table 4.29.	Summary of reported fire occurrences in Catchment Forest Reserves for Morogoro Rural District, 1989-1993	101
Table 4.30.	Land acquisition methods in Tanzania	108

LIST OF FIGURES

Figure 1.1	Map of Tanzania with Africa inset, showing the Geographic location of the "Eastern Arc" mountains. Mount Kilimanjaro (a recent volcanic mountain) is not one of the "Eastern Arc" mountains but is included as a landmark. The Nguru mountains can be seen in the middle of the mountain chain	5
Figure 1.2.	The vicious circles to illustrate some complex processes perpetuating environmental degradation and declining productivity in unstable tropical agriculture	7
Figure 2.1.	System causality of deforestation and regressive development process in developing countries	26
Figure 2.2	Change in land classes related to deforestation in Africa 1980-1990	34
Figure 3.1.	Map showing road access to the Nguru mountains	45
Figure 3.2.	Map of the Nguru mountain area showing Nguru South Forest Reserve and Mhonda village	46
Figure 4.1.	Scheme to illustrate the major vegetation types in the Nguru mountains	54
Figure 4.2.	Schematic diagram showing the relation between landuse problems and main factors causing landuse problems in the Nguru mountains	105

LIST OF APPENDICES

- Appendix 1. Sample questionnaire for household survey
- Appendix 2. Calendar of major events in the evolution of land tenure in Tanzania
- Appendix 3. Organization and management responsibilities of the four Regional Catchment Forestry Projects funded by NORAD in Tanzania
- Appendix 4. Illustration of pitsawing activities in the Nguru South Forest Reserve, Nguru Mountains, Tanzania

LIST OF ACRONYMS

AICC	Arusha International Conference Centre
a.s.l.	above sea level
AUN	Agricultural University of Norway
CFP	Catchment Forestry Project
CPP	Community Participation Project
ERP	Economic Recovery Programme
FAO	Food and Agriculture Organization
FBD	Forestry and Beekeeping Division
GEMS	Global Environment Monitoring System of UNEP
GIS	Geographic Information System
GNP	Gross National Product
HADO	Hifadhi Ardhi Dodoma Project
HASHI	Hifadhi Ardhi Shinyanga Programme
HIMA	Hifadhi Mazingira Programme
IDRC	International Development Research Centre, Canada
IFAD	International Fund for Agriculture Development
IUCN	International Union for Conservation of Nature
IUFRO	International Union for Forestry Research Organization
LAMP	Land and Agriculture Management Programme
MNRSA	Management of Natural Resources and Sustainable Agriculture
MWAP	Morogoro Women Afforestation Project
NCSSD	National Conservation Strategy for Sustainable Development
NEAP	National Environmental Action Plan
NESP	National Economic Survival Plan
NGO	Non Governmental Organization
NORAD	Norwegian Agency for International Development
NORAGRIC	Norwegian Centre for International Agricultural Development
PRA	Participatory Rural Appraisal
SADCC	Southern Africa Development Coordination Conference
SAP	Structural Adjustment Programme
SECAP	Soil Erosion Control and Afforestation Programme
TFAP	Tanzania Forestry Action Plan
T.Shs.	Tanzania Shillings
UK	United Kingdom
UNEP	United Nations Environment Programme
UNESCO	United Nations Educational, Scientific and Cultural Organization
URT	United Republic of Tanzania
USA	United States of America
USD	United States Dollar
USDA	United States Department of Agriculture
WCED	World Commission on Environment and Development
WRI	World Resources Institute

METRIC UNITS

mm
cm
m
km
ha
g
kg
t

millimetre
centimetre
metre
kilometre
hectare
gramme
kilogramme
metric tonne

1.0 INTRODUCTION

1.1 Rain forests: distribution and importance in Tanzania

In the FAO 1990 Forest Resource Assessment, "forests" are defined as ecosystems with a minimum of 10 percent crown cover of tree and/or bamboos, generally associated with wild flora, fauna and natural soil conditions and not subject to agricultural practices (Adger & Brown 1994). In mainland Tanzania, about 50 percent of the total land area is forest and woodland, 40 percent is grassland and scrub and 6 to 8 percent is cultivated (NCSSD 1994). Table 1.1 shows the patterns of landuse for the whole country.

Table 1.1. Patterns of landuse in Tanzania

Landuse	Area (million, ha)	Percentage
Smallholder cultivation	4.1	5
Large scale agriculture	1.1	1
Grazing land	35.0	39
Woodland and forest	44.4	50
Other land	4.0	5
TOTAL	88.6	100

Source: NCSSD 1994.

The types of forests present in Tanzania are shown in Table 1.2. About 3.5 percent or 1.5 million ha (including mangroves) of the country is covered by closed forests, mainly rainforests (NCSSD 1994). However, true tropical rainforests now cover only about 2 percent of the country (NEAP 1994). In the FAO 1990 Forest Resource Assessment, "closed forests" are defined as ecosystems where trees of different stories and the undergrowth cover a large portion of the ground and no grass cover exists (Adger & Brown 1994). In spite of their relatively small area, rainforests are undoubtedly valuable to Tanzania. The rainforests are a home to many plant and animal species (Bjørndalen 1992). The montane rainforests are reserved as important water catchments supplying water for the major cities and densely populated areas. They also play an important role in soil erosion control, community stability, old growth ecology, storage of carbon, aesthetic and cultural value. They are also a source of timber and many other nontimber benefits (TFAP 1989).

Table 1.2. Distribution of the forest estate in Tanzania

Type of forest	Area (million, ha)	Percentage
Closed forests (excluding mangrove)	1.4	3.2
Mangrove forest	0.1	0.3
Woodlands	42.9	96.5
TOTAL	44.4	100.0

Source: NCSSD (1994)

Furthermore, these rainforests derive their high value from the high biodiversity, characterized by the presence of large numbers of endemic and near endemic species and taxa of both flora and fauna. This feature of rainforests in Tanzania has been mentioned by several authors such as Polhill (1968), Axelrod & Raven (1978), Brenam (1978), Johansson (1978), Kalaghe *et al.* (1988), Lovett (1988a, 1988b & 1989), Hamilton & Bensted-Smith (1989), Hamilton & Mwashia (1989), Howell (1989), Mather (1989), Ruffo *et al.* 1989, TFAP (1989), Pócs, Temu & Minja (1990), Mascarenhas (1991) and Bjørndalen (1992). Apart from the scientific importance of such endemic species and taxa, many are famous for various local uses (Pócs 1990, Norris 1990 & Bjørndalen 1992). As such biodiversity is one of the country's greatest assets.

The catchment role and biological diversity are the main reasons for the concern against destruction of the rainforests. Also the knowledge that destruction of these forests is an irreversible process due to the difficulty to regenerate them once they are destroyed (TFAP 1989, Hofstad 1990). Table 1.3 shows the area distribution of the Catchment Forest Reserves (mainly tropical rainforests) in Tanzania. Rainforests are now confined to mountain areas, hills and river valleys with a scattered island-like appearance throughout the distribution area ((Hamilton & Bensted-Smith 1989, Iversen 1989, Bjørndalen 1992). They are mainly found on the chain of mountains which extend from South of the country, to the north-eastern part and collectively designated as the "Eastern Arc" mountains of Tanzania (Figure 1.1). The Usambara, Udzungwa, Nguru, Uluguru and Pare mountains are the main mountain ranges which form the "Eastern Arc" mountains. The rest of the rainforests are found on isolated volcanic mountains particularly the Kilimanjaro, Meru and Ngorongoro Crater in the North; Mount Rungwe in the South and the Mahale mountains on the shores of Lake Tanganyika (TFAP 1989, Mascarenhas 1991, Bjørndalen 1992). Some rainforests are also found on the foothills of other isolated mountains in the country and where permanent ground water exist such as riparian forests in river valleys (Ahlback 1986 & 1988, Bjørndalen 1992).

1.2 Human impact in and around the tropical rainforests in Tanzania

Naturally, rainforests in Tanzania are located in fertile areas which receive relatively sufficient and reliable rainfall. Such areas are characterized by high population density and much human pressure on land and forest resources hence resulting into land degradation and deforestation. The consequences of degradation and deforestation in the tropical rainforests include soil erosion, siltation, flooding in river basins, changes in microclimate, loss of habitat, destruction of food chains among others (Dasgupta 1982). Forest degradation and deforestation taking place in Tanzania may be attributed to a complex of processes which have broken down the traditional resource management systems (Mascarenhas 1991, Solberg *et al.* 1994). The vicious circles (Figure 1.2) perpetuating environmental degradation and declining productivity in unstable tropical agriculture may serve to illustrate some of these complex processes. A similar situation is taking place around rainforests in Tanzania leading to forest degradation and deforestation (TFAP 1989). Historically, human interference in natural forests has taken place ever since humans began to exploit the environment. Schmidt (1989) notes that the East African forests have been exploited by humans for more than 2000 years and the impact of exploitation varied from time to time.

Table 1.3. Area distribution of Catchment Forest Reserves in Tanzania

(A) Eastern Arc mountains (74 reserves) - 572 213 ha	
N. ⁽¹⁾ Pare Mts. (3 reserves)	4 760 ha
S. Pare Mts. (3 reserves)	19 828 ha
W. Usambara Mts. (11 reserves)	20 804 ha
E. Usambara Mts. (13 reserves)	17 246 ha
Nguru Mts. (11 reserves)	61 247 ha
Ukaguru Mts. (8 reserves)	17 593 ha
Rubeho Mts. (2 reserves)	65 535 ha
Uluguru Mts. (7 reserves)	29 354 ha
Uzungwa Mts. (8 reserves)	329 439 ha
Mahenge (8 reserves)	6 407 ha
(B) Other catchment forest reserves in Tanga and Morogoro Regions (28 reserves) - 51 801 ha	
Tanga: Handeni District (6 reserves)	4 191 ha
Tanga: Korogwe District (11 reserves)	16 680 ha
Morogoro (excl. Eastern Arc mountains) (11 reserves)	30 930 ha
(C) Volcanic mountains in Kilimanjaro and Arusha Regions (20 reserves) - 367 249 ha	
Mt. Kilimanjaro (4 reserves)	110 197 ha
Mt. Meru (1 reserve)	26 444 ha
Ngorongoro District (1 reserves + 4 proposed reserves)	124 409 ha
Rift Valley Escarpment in Babati, Mbulu and Hanang Districts (7 reserves)	93 491 ha
Monduli District (3 reserves)	12 708 ha
Total area for catchment forest reserves in Morogoro, Tanga, Kilimanjaro, Arusha and parts of Iringa Regions (122 reserves): 991 263 ha	
Total area for catchment forest reserves in Tanzania: ca. 1.6 mill. ha	
Percent of total area:	
Eastern Arc mountains	36%
Volcanic mountains in Kilimanjaro and Arusha Regions	23%
Covered by NORAD catchment project	43%
Included in this Table	62%

Source: Bjørndalen (1991).

Footnote: (1) N. = North, S. = South, W. = West, E. = East.

However, the most serious degradation of rainforests in Tanzania has undoubtedly taken place in the second half of this present century and the last 30 years have had very big impact (Kalaghe *et al.* 1988, Hamilton & Mwashia 1989, Bjørndalen 1992). The various human impacts on the rainforests in Tanzania have been reviewed by several authors such as Hermansen *et al.* (1985), Lundgren (1985), Rodgers & Hall (1986), Kalaghe *et al.* (1988), Pócs (1988), Hamilton & Bensted-Smith (1989), Kaoneka (1990), Nsolomo & Chamshama (1990), Hedberg & Persson (1990), Bjørndalen & Pócs (1991), Newmark (1991) and Bjørndalen (1992). All suggest that forest degradation is severe but fall short of identifying the underlying causes and quantifying the extent of the damage. They also lack empirical data. As part of the ongoing global concern for the environment, forest conservation in Tanzania, has been given high priority (Mascarenhas 1991, NCSSD 1994). The basis for this concern is that there is ample evidence of forest and environmental degradation as testified by the apparent high rate of deforestation, decline in forest products, decline in crop productivity, drying up of streams and many other effects (Mascarenhas 1991).

Thus through the Tanzania Forestry Action Plan for the period 1990/91-2007/08, The National Conservation Strategy for Sustainable Development (NCSSD) (1994) and the National Environmental Action Plan (NEAP) (1994), the Government has restated its objective that deforestation and environmental degradation in general must be halted in the interest of the present and future generations (Mascarenhas 1991). Basically, the NCSSD (1994) identifies six major environmental problems for urgent national attention in Tanzania. These are problems of (a) land degradation; (b) lack of accessible, good quality water for both rural and urban inhabitants; (c) pollution; (d) loss of wildlife habitats; (e) deterioration of marine and fresh water systems; (f) deforestation. Each of these is important to the economic well-being of the country and the health of people. Land degradation and deforestation are issues of main concern in Monela (1995a), the present study.

1.3 Forest and land degradation in the Nguru mountains

Figure 1.1 shows the location of the Nguru mountains in Tanzania. Morogoro town ($6^{\circ} 48' S$; $37^{\circ} 40' E$), located at 500 metres above sea level (m.a.s.l.), is the nearest large town located about 150 km south of Turiani (largest human settlement in the Nguru mountains) and about 200 km West of Dar es Salaam, the capital city of Tanzania (Figure 3.1). The Nguru mountains are situated roughly in the center of the "Eastern Arc" mountain chain of Tanzania (Figure 1.1). They extend from about $5^{\circ} 5' S$ and $37^{\circ} 45' E$ to $6^{\circ} 20' S$ and $37^{\circ} 20' E$. Mhonda village (Figure 3.2) which is the most important station on the eastern slopes is located at $6^{\circ} 08' S$ and $37^{\circ} 35' E$ at 540 m a.s.l.. The Nguru mountains are among the few remaining areas in Tanzania where patches of the relatively undisturbed tropical rainforest still exist. The coincidence of the tropical rainforest environment in the area has imparted its own peculiarities to the landuse problems. Consequently, the Government has reserved this pristine ecosystem to serve as a water catchment for the densely populated Turiani area and other places (Bjørndalen 1991).

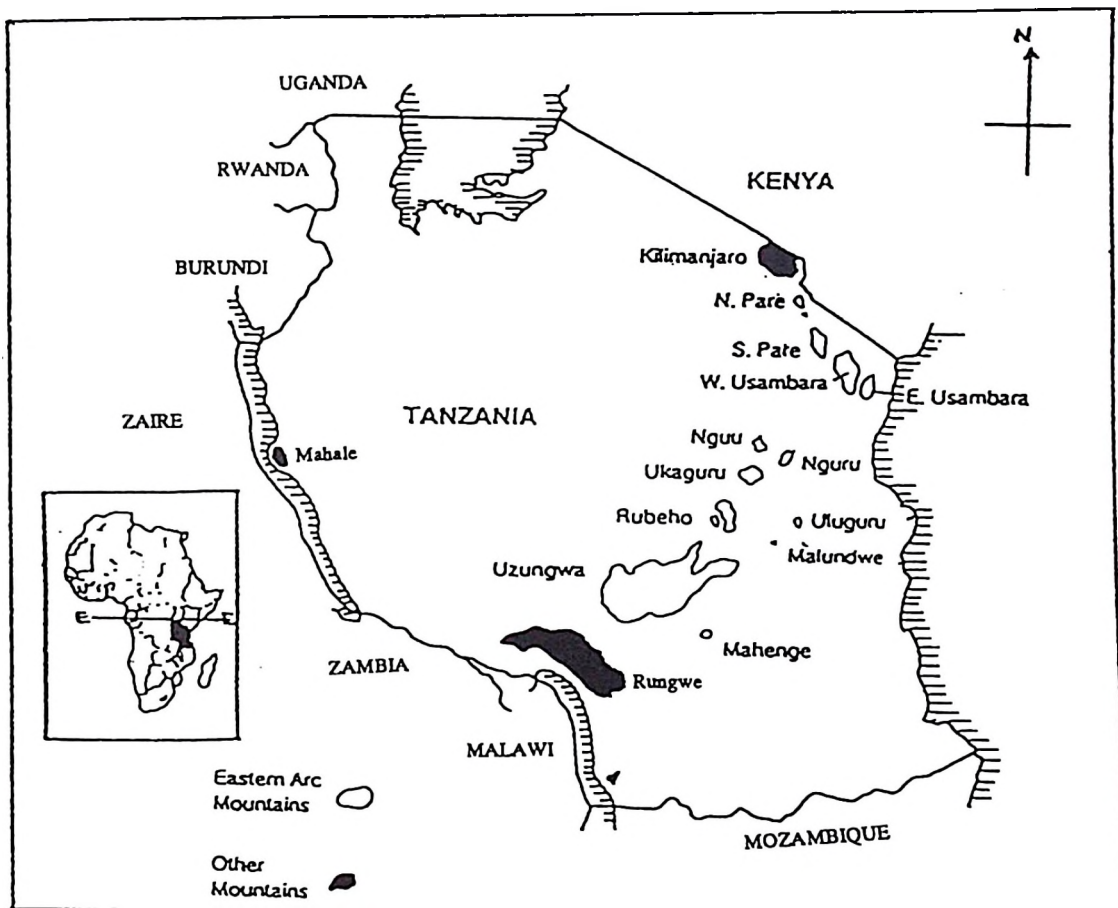

Figure 1.1 Map of Tanzania with Africa inset, showing the Geographic location of the "Eastern Arc" mountains. Mount Kilimanjaro (a recent volcanic mountain) is not one of the "Eastern Arc" mountains but is included as a landmark. The Nguru mountains can be seen in the middle of the mountain chain.
(Source: Adapted from Hamilton & Bensted-Smith (1989).

However, intense cultivation, excessive exploitation of the natural forest and poor landuse practices in and around the Forest Reserve have affected the forest from all sides to the extent that it looks as an isolated, fragmented island surrounded by the cultural landscape (Bjørndalen 1992). The human pressure on the forest caused by socio-economic activities in the area has progressively been mounting. Some preliminary studies for rainforests in Morogoro region in recent years (Chamshama *et al.* 1990, Norris 1990, Nsolomo & Chamshama 1990; Bjørndalen 1991, Bjørndalen & Pócs 1991, Bjørndalen 1992) suggest that the situation calls for immediate action if conservation objectives are to be achieved and to avoid the threat of decimating the rainforest (Bjørndalen 1992). It is upon this background that there has been a growing concern for protecting the rainforests in the Nguru mountains as part of the high priority given to catchment forestry in the Tanzania Forestry Action Plan.

1.4 Objectives of the study

Sustainable landuse requires improving conditions through raising productivity to bring development (Beets 1990). However, raising productivity is not merely a technical, nor an economic problem; neither is it simply a social, organizational or political issue. The success of development activities are dependent on an understanding of the society in which it is to take place, a knowledge of the social and cultural factors that govern farmer's response to change, and the ability and willingness of all parties involved in the development process (*ibid.*). People can only cooperate in development endeavours if their standard of living is raised before, or very soon after, they have made a contribution to development. Hence, the first priority of moving from a chronic state of under-development must be raising the people's standard of living. If this is not done, if low self-esteem, limited freedom and low standards of living are allowed to prevail, the prospects of development become gloomy (Todaro 1980).

Therefore, the broad objective of this study is to identify the main landuse and landuse problems with reference to agriculture and forestry in the Nguru mountains, and the main factors causing these landuse problems, and analyze ways to reduce them in order to prevent forest degradation and deforestation. The more specific objectives are:

- (i) To describe the ecological and socio-economic aspects of landuse in the Nguru mountains with respect to forest degradation and deforestation.
- (ii) To examine the nature and type of landuse practices in the Nguru mountains.
- (iii) To analyze landuse problems affecting forest resources in this area.
- (v) To identify the main factors causing landuse problems in there.
- (vi) To recommend possible measures to control landuse in order to prevent forest degradation and deforestation.

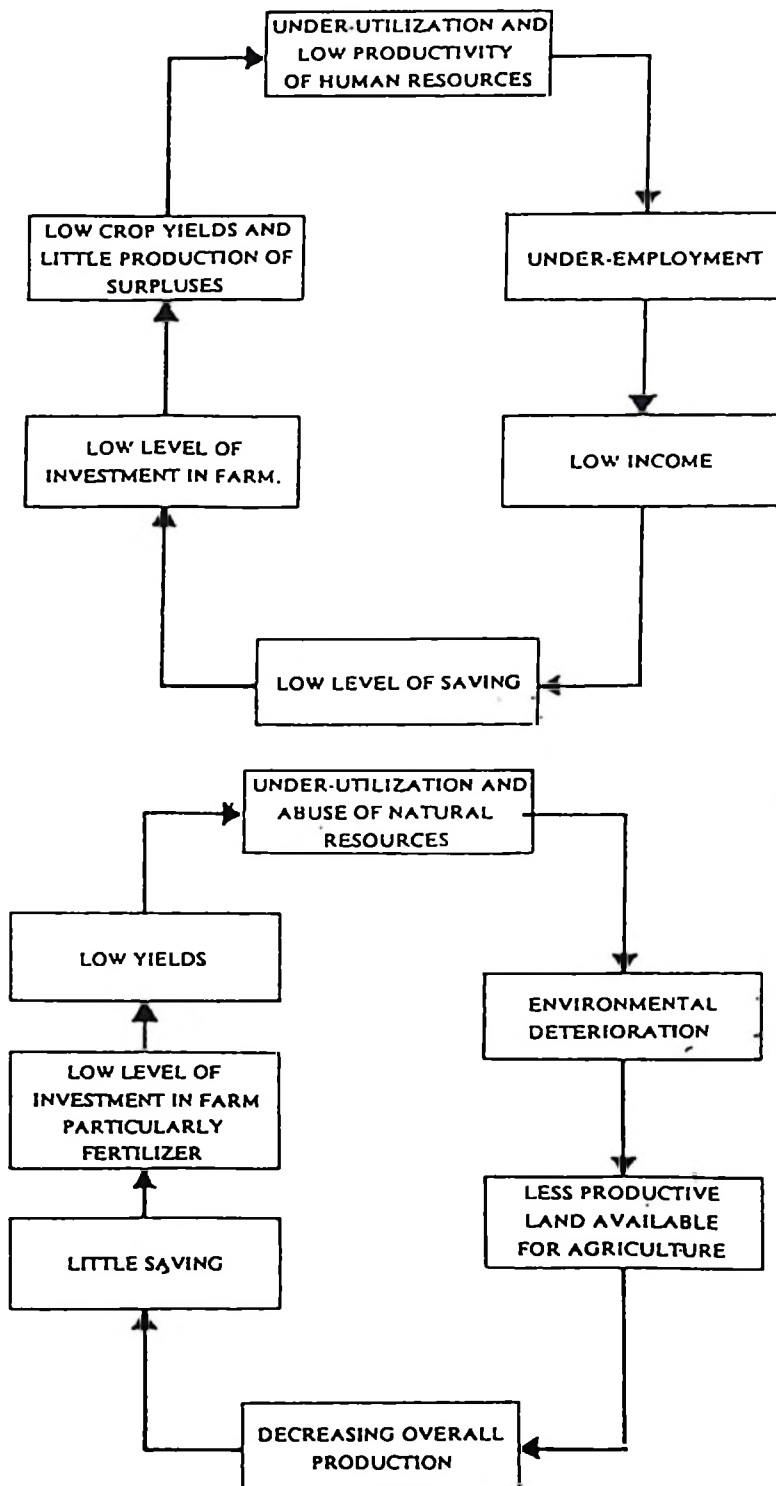

Figure 1.2. The vicious circles to illustrate some complex processes perpetuating environmental degradation and declining productivity in unstable tropical agriculture.
Source: Beets (1990) p. 51.

1.5 Study outline and main limitations

1.5.1 Study outline

The objectives of this study are addressed in five chapters of the present report. Due to the nature of the issues being addressed, there may be overlapping of some issues/points due to lack of clearcut distinction between landuse problems and causes, or between agents and underlying causes of landuse problems. There are many factors which cause landuse problems, thus what are presented here, are those factors which were found particularly important in the Nguru mountains. While most of the research efforts concentrated on the fulfillment of the study objectives, considerable effort and time was also devoted for relevant literature review presented in Chapter 2 focusing on review of peasant farming and landuse, the socio-economic aspects of forest resource management, utilization, degradation and deforestation. Much attention was also given to the theories and general background on socio-economic aspects of forest degradation and deforestation in developing countries and in Tanzania. Estimates of deforestation and landuse change data are also presented. Focus was also on the role of property rights in forest resource management and utilization, and the connection between deforestation and various factors. The chapter ends by reviewing some relevant empirical studies on deforestation and forest degradation particularly in Tanzania.

Chapter 3 describes the study methodology, with main focus on the study area description, methods of data collection and data analysis. The study methodology used was mainly interviews, field observations and use of secondary sources. Chapter 4 presents study results and discussions. These are presented in the context of the role of ecological and socio-economic factors which have shaped existing landuse practices, landuse problems and main factors causing landuse problems in the Nguru mountains. The main landuses are agriculture and forestry. Therefore, the landuse problems presented focus mainly on agriculture and forestry. The role of ecological and socio-economic factors in causing landuse problems is emphasized. The report also presents estimates of landuse changes and deforestation rates as a consequence of landuse problems in the Nguru mountains. Chapter 5 presents the general conclusions and recommendations from the study focusing on why there are landuse problems, their impact on agriculture and forestry, and what need to be done to prevent them. Finally several appendices are presented.

1.5.2 Main study limitations

The study has the following limitations which must be taken into account when interpreting the results:

- (i) Responses to the interviews and the questionnaire are based on respondents memory since most villagers keep no written record of their activities.
- (ii) There was a possibility of interviewers misunderstanding responses and interviewees misunderstanding the questions. This includes subjective judgement and bias on the part of enumerators.
- (iii) Estimates made during field observation may be biased due to local influences or incorrect assumptions regarding the local situation.

- (iv) There is a possibility of overlap between landuse problems and causes of landuse problems also between the driving forces and agents of landuse problems.
- (v) Financial and time limitation constrained the scope and detail of data collection and analysis.
- (vi) There was data paucity on certain variables necessitating the use of proxy values to measure some variables.
- (vi) Some results are also reported in Monela (1995b and 1995c) hence low level of detail and the need to view the three reports as one, in the overall perspective.

2.0 LITERATURE AND THEORETICAL CONCEPTS ON SOCIO-ECONOMIC ASPECTS OF FOREST RESOURCE MANAGEMENT, UTILIZATION, DEGRADATION AND DEFORESTATION.

2.1 Review of Peasant farming and landuse

According to Beets (1990), 70-80 percent of the people of developing countries are subsistence peasant farmers. In subsistence farming, continuous production of food for daily livelihood is a must, even when it is unprofitable and uneconomic, because if the farmer stops producing, he and his family will starve (*ibid.*). This has major implications for production methods. It has become apparent in recent times that peasants population, their effect on the land and the extent of the reaction to the increase in wealth of other sections of the population has become a major force that we can no longer afford to ignore (WCED 1987). The reason is that peasants are characterized by one important aspect of their life which is farming associated with overuse of land and vegetation accompanied by degradation due to lack of inputs (Ormerod 1983). Poverty and hunger which are common in peasant life lead to environmental degradation, deteriorating agriculture and hence creating more poverty and hunger (Low 1986, FAO 1991). Economic return which is considered to be the sole criterion for efficient agriculture has progressively been declining among the peasants (WCED 1987). Thus the occurrence of mass poverty among the peasants is a consequence of poor economic returns from agriculture and this has been influenced partly by social, political and climatic conditions (Ormerod 1983).

According to Lopez & Anderson (1983), the peasants have a physiocratic view of the land and therefore they consider land as the source of all wealth. Also their agriculture is closely contiguous and linked to economic development. Consequently, economic development and commercialization of agriculture has destabilized the peasant farmers, without putting in place anything much more productive to replace declining peasant farming productivity. Food production has declined and peasants are progressively being marginalized. The high demand for food, stimulated by population growth, has been liable to increased need for arable land. However, the quest for development has instead of promoting agriculture, deterred it, thus marginalizing the peasants, lowering productivity and degrading agriculture as a whole (Holden 1991). According to Low (1986), the peasants over the years evolved agriculture techniques which enabled them to grow food crops on increasingly poor soils. These often were associated with periods of fallow, when regrowth of the natural vegetation over a period of years, restored fertility to a patch of land which could then be used for one or more years. Alternatively, they used manure from animal dung which allowed some form of fixed but not intensive agriculture. It means that, farmers have avoided agricultural risks by relying, to a large extent, on production methods and techniques developed over centuries, and based on the accumulated experience of generations of farmers. These methods, though result in low yields, are stable and until recently, they were quite sound, ecologically. However, low yields result in little surplus production, which in turn means that, few resources can be made available for acquiring external inputs which are now, so important if appropriate landuse practices are to be adhered (Beets 1990). Thus these and other difficult strategies, enabled the peasant farmer to live on borders of starvation. On this account, the peasants were able to use bad land most effectively, but their operations always

became increasingly difficult mainly because of pressures that the modern world exerts upon them (Somogyi 1989).

Therefore by far, the most important land and forest degradation occurring today, is due to the social and economic effects of modern life on the peasant farmer and the way in which they are destabilizing his way of life (Ormerod 1983). The pace of modern economic development has also increased the farmer's demand for cash and higher standard of living, whatever his supposed traditions of independence, frugality, and distance from the cash economy. Nomads living on marginal lands are being compelled to sell their beasts for cash and arable farmers to sell their staples and to produce a wider range of cash crops (FAO 1991). Goods such as steel hoes, machetes, shotguns, bicycles and transistor radios are increasingly desired by the peasant, while inflation makes their cost even greater in terms of crops produced but not consumed by the farmer and his family. Among the consequences of this situation is that, peasants resort to agricultural forms that involve uncovering of the soil of its natural vegetation (WCED 1987). As the intensity of agriculture becomes greater, more soil is uncovered and exposed to more destruction due to soil erosion and leaching of soil nutrients (Sharma 1992).

According to Beets (1990), there are other factors that influence peasant farming. The alternation of dry and rainy seasons is one of them. Agricultural production is significantly affected by a steep gradient of rain period followed by long dry spells. Often, rains come when the peasant farmer may be suffering from malnutrition at the end of the dry season. Ostensibly, this is the peak of his activity, when his survival depends upon the success of his farming operations. Also when rains come, such is the rapidity of growth of both crops and weeds that the farmer's prosperity depends on the number of hands that he can muster at this time. While many strategies are used for obtaining additional labour, the farmer's only sure method is to increase his family size. Thinking of labour saving devices is precluded because of poverty. However, large family size puts the farmer in even more greater demand for food and commodities and with present income levels, he is compelled to struggle for survival rather than improving yields. Coupled with political decisions that affect the use of land and its resources, the peasant farmer is totally alienated from economic development and simultaneously pushed to marginal lands and in the vicious circle of poverty. In the Nguru mountains, where most of the people are peasant farmers, the area is very vulnerable to ecological degradation emanating from economic activities in the struggle for survival. The responses of the peasants to economic hardships facing them, has a strong bearing to the way they use the resources at their disposal such as land, forests, capital, time and labour. The way resources are utilized on the other hand, has a strong influence on landuse practices and hence landuse problems (Kaoneka 1993).

2.2 Broad perspective of landuse problems and landuse changes

According to WCED (1987), human activities have radically reshaped the land natural cover in many places. Vast areas of forests have become pasture and croplands, rangelands have been changed to croplands or to deserts, and natural wetland have been drained and filled, in order to feed and house expanding populations. These human activities have drastically changed the balance of land availability and consequently landuse itself. Landuse problems which are closely

linked to the degradation of the renewable natural resources such as forests are taking a serious toll in retarding economic development. Deforestation being among the important consequences of landuse problems is a threat to biological diversity and climate. Serious soil erosion reduces the capacity to satisfy expanding demands for agricultural commodities. It also jeopardizes the benefits of water resource development. The continuing growth in human population and economic development places increasingly heavy demands on finite resource base. Overexploitation and poor management also takes its toll and in some areas have led to a serious modification or depletion of the resource base (Sharma 1992).

Poor communities are typically dependent on agrarian and pastoral activities and are thus most often vulnerable to effects of environmental degradation. This is due in part, to the shortage of human and financial capital that severely limit their ability to turn to other economic activities, when the natural resource base can no longer sustain them. Also the fact that despite a widespread concern over environmental problems, analysis of resource degradation in such communities is still rudimentary (Lele 1975). In most of these communities the combination of poverty, unequal distribution of land and other resources and population growth is creating incentives for people to overexploit existing resources in order to survive. Exacerbating this is the fact that, economic systems do not always contain automatic self-regulating mechanisms for ensuring perpetual environmental sustainability of current economic development paths (Palo & Mery 1990, Grainger 1993). According to WCED (1987) and Sharma (1992) inequalities in access to natural resources, commercialization of demand for resources, breakdown of traditional resource management systems under external commercial pressure, with the growing of populations and the rising subsistence requirements, are viewed to have contributed significantly to the depletion of the natural resources in most areas. Also the conditions governing the availability and use of the renewable resources, the structure of incentives and disincentives, and the enforcement of the environmental standards, have determined the resource management practices, environmental damage caused and resource depletion. The policies adopted have promoted more intensive exploitation of the remaining natural resources in many places (*op.cit.*).

Globally, the apparent trend of accelerating environmental degradation in recent times has primarily been driven by landuse changes as a consequence of frontier expansion and population growth (Richards 1990). Table 2.1 shows global landuse trends from 1700 to 1980 based on various databases and models summarized by Richards (1990). One important landuse change is that the world's forests and woodlands have declined and are now 81 percent of their 1700 total. The expansion of the cropped land area is almost the same magnitude, though the areas are not coextensive (Adger & Brown 1994). Furthermore, the rate of landuse changes have increased dramatically this century, with the absolute changes in world cropland being greater in the period 1950-1980 than in the 250 years before then. Increased productivity of labour in exploiting land through the application of capital and technologies have been the major driving force for these landuse changes in the last 300 years (*op. cit.*). The agricultural revolution and the opening of frontier land in particular may explain the conversion of land from natural to agricultural use. Population growth is a driving force behind increasing productive use of land and also of the intensity of landuse although the causality between population growth, technological innovation and landuse change is unclear (Boserup 1965, Adger & Brown 1994).

Table 2.1. Global landuse change 1700-1980

Regions	Vegetation types	Area (million ha)					% changes from				
		1700	1850	1920	1950	1980	1700 to 1850	1850 to 1920	1920 to 1950	1950 to 1980	1700 to 1980
Africa	Forests and woodlands	1396	1370	1302	1206	1088	-1.9	-5.0	-7.4	-9.8	-22.1
	Grassland and pasture	2175	2180	2203	2227	2218	0.2	1.1	1.1	-0.4	2.0
North America	Croplands	64	84	131	202	329	31.3	56.0	54.2	62.9	414.1
	Forests and woodlands	1016	971	944	939	942	-4.4	-2.8	-0.5	0.3	-7.3
Latin America	Grassland and pasture	915	914	811	789	790	-0.1	-11.3	-2.7	0.1	-13.7
	Croplands	3	50	179	206	203	1566.7	258.0	15.1	-1.5	666.7
China	Forests and woodlands	1445	1420	1369	1273	1151	-1.7	-3.6	-7.0	-9.6	-20.3
	Grassland and pasture	608	621	646	700	767	2.1	4.0	8.4	9.6	26.2
Other Asia	Croplands	7	18	45	87	142	157.1	150.0	93.3	63.2	1928.6
	Forests and woodlands	135	96	79	69	58	-28.9	-17.7	-12.7	-15.9	-57.0
Europe	Grassland and pasture	951	944	941	938	923	-0.7	-0.3	-0.3	-1.6	-2.9
	Croplands	29	75	95	108	134	158.6	26.7	13.7	24.1	362.1
Former USSR	Forests and woodlands	588	569	536	493	415	-3.2	-5.8	-8.0	-15.8	-29.4
	Grassland and pasture	314	312	304	295	279	-0.6	-2.6	-3.0	-5.4	-11.1
Pacific countries	Croplands	57	78	119	171	265	36.8	52.6	43.7	55.0	364.9
	Forests and woodlands	230	205	200	199	212	-10.9	-2.4	-0.5	6.5	-7.8
TOTAL	Grassland and pasture	190	150	139	136	138	-21.1	-7.3	-2.2	1.5	-27.4
	Croplands	67	132	147	152	137	97.0	11.4	3.4	-9.9	104.5
TOTAL	Forests and woodlands	1138	1067	987	952	941	-6.2	-7.5	-3.5	-1.2	-17.3
	Grassland and pasture	1068	1078	1074	1070	1065	0.9	-0.4	-0.4	-0.5	-0.3
TOTAL	Croplands	33	94	178	216	233	184.8	89.4	21.3	7.9	606.1
	Forests and woodlands	267	267	261	258	246	0.0	-2.2	-1.1	-4.7	-7.9
TOTAL	Grassland and pasture	639	638	630	625	608	-0.2	-1.3	-0.8	-2.7	-4.9
	Croplands	5	6	19	28	58	20.0	216.7	47.4	107.1	1060.0
TOTAL	Forests and woodlands	6215	5965	5678	5389	5053	-4.0	-4.8	-5.1	-6.2	-18.7
	Grassland and pasture	6860	6837	6748	6780	6788	-0.3	-1.3	0.5	0.1	-1.0
TOTAL	Croplands	265	537	913	1170	1501	102.6	70.0	28.1	28.3	466.4

Source: Adapted from Richards (1990), p. 164.

linked to the degradation of the renewable natural resources such as forests are taking a serious toll in retarding economic development. Deforestation being among the important consequences of landuse problems is a threat to biological diversity and climate. Serious soil erosion reduces the capacity to satisfy expanding demands for agricultural commodities. It also jeopardizes the benefits of water resource development. The continuing growth in human population and economic development places increasingly heavy demands on finite resource base. Overexploitation and poor management also takes its toll and in some areas have led to a serious modification or depletion of the resource base (Sharma 1992).

Poor communities are typically dependent on agrarian and pastoral activities and are thus most often vulnerable to effects of environmental degradation. This is due in part, to the shortage of human and financial capital that severely limit their ability to turn to other economic activities, when the natural resource base can no longer sustain them. Also the fact that despite a widespread concern over environmental problems, analysis of resource degradation in such communities is still rudimentary (Lele 1975). In most of these communities the combination of poverty, unequal distribution of land and other resources and population growth is creating incentives for people to overexploit existing resources in order to survive. Exacerbating this is the fact that, economic systems do not always contain automatic self-regulating mechanisms for ensuring perpetual environmental sustainability of current economic development paths (Palo & Mery 1990, Grainger 1993). According to WCED (1987) and Sharma (1992) inequalities in access to natural resources, commercialization of demand for resources, breakdown of traditional resource management systems under external commercial pressure, with the growing of populations and the rising subsistence requirements, are viewed to have contributed significantly to the depletion of the natural resources in most areas. Also the conditions governing the availability and use of the renewable resources, the structure of incentives and disincentives, and the enforcement of the environmental standards, have determined the resource management practices, environmental damage caused and resource depletion. The policies adopted have promoted more intensive exploitation of the remaining natural resources in many places (*op.cit.*).

Globally, the apparent trend of accelerating environmental degradation in recent times has primarily been driven by landuse changes as a consequence of frontier expansion and population growth (Richards 1990). Table 2.1 shows global landuse trends from 1700 to 1980 based on various databases and models summarized by Richards (1990). One important landuse change is that the world's forests and woodlands have declined and are now 81 percent of their 1700 total. The expansion of the cropped land area is almost the same magnitude, though the areas are not coextensive (Adger & Brown 1994). Furthermore, the rate of landuse changes have increased dramatically this century, with the absolute changes in world cropland being greater in the period 1950-1980 than in the 250 years before then. Increased productivity of labour in exploiting land through the application of capital and technologies have been the major driving force for these landuse changes in the last 300 years (*op. cit.*). The agricultural revolution and the opening of frontier land in particular may explain the conversion of land from natural to agricultural use. Population growth is a driving force behind increasing productive use of land and also of the intensity of landuse although the causality between population growth, technological innovation and landuse change is unclear (Boserup 1965, Adger & Brown 1994).

Table 2.1. Global landuse change 1700-1980

Regions	Vegetation types	Area (million ha)					% changes from				
		1700	1850	1920	1950	1980	1700 to 1850	1850 to 1920	1920 to 1950	1950 to 1980	1700 to 1980
Africa	Forests and woodlands	1396	1370	1302	1206	1088	-1.9	-5.0	-7.4	-9.8	-22.1
	Grassland and pasture	2175	2180	2203	2227	2218	0.2	1.1	1.1	-0.4	2.0
North America	Croplands	64	84	131	202	329	31.3	56.0	54.2	62.9	414.1
	Forests and woodlands	1016	971	944	939	942	-4.4	-2.8	-0.5	0.3	-7.3
Latin America	Grassland and pasture	915	914	811	789	790	-0.1	-11.3	-2.7	0.1	-13.7
	Croplands	3	50	179	206	203	1566.7	258.0	15.1	-1.5	666.7
China	Forests and woodlands	1445	1420	1369	1273	1151	-1.7	-3.6	-7.0	-9.6	-20.3
	Grassland and pasture	608	621	646	700	767	2.1	4.0	8.4	9.6	26.2
Other Asia	Croplands	7	18	45	87	142	157.1	150.0	93.3	63.2	1928.6
	Forests and woodlands	135	96	79	69	58	-28.9	-17.7	-12.7	-15.9	-57.0
Europe	Grassland and pasture	951	944	941	938	923	-0.7	-0.3	-0.3	-1.6	-2.9
	Croplands	29	75	95	108	134	158.6	26.7	13.7	24.1	362.1
Former USSR	Forests and woodlands	588	569	536	493	415	-3.2	-5.8	-8.0	-15.8	-29.4
	Grassland and pasture	314	312	304	295	279	-0.6	-2.6	-3.0	-5.4	-11.1
Pacific countries	Croplands	57	78	119	171	265	36.8	52.6	43.7	55.0	364.9
	Forests and woodlands	230	205	200	199	212	-10.9	-2.4	-0.5	6.5	-7.8
TOTAL	Grassland and pasture	190	150	139	136	138	-21.1	-7.3	-2.2	1.5	-27.4
	Croplands	67	132	147	152	137	97.0	11.4	3.4	-9.9	104.5
Former USSR	Forests and woodlands	1138	1067	987	952	941	-6.2	-7.5	-3.5	-1.2	-17.3
	Grassland and pasture	1068	1078	1074	1070	1065	0.9	-0.4	-0.4	-0.5	-0.3
Pacific countries	Croplands	33	94	178	216	233	184.8	89.4	21.3	7.9	606.1
	Forests and woodlands	267	267	261	258	246	0.0	-2.2	-1.1	-4.7	-7.9
TOTAL	Grassland and pasture	639	638	630	625	608	-0.2	-1.3	-0.8	-2.7	-4.9
	Croplands	5	6	19	28	58	20.0	216.7	47.4	107.1	1060.0
TOTAL	Forests and woodlands	6215	5965	5678	5389	5053	-4.0	-4.8	-5.1	-6.2	-18.7
	Grassland and pasture	6860	6837	6748	6780	6788	-0.3	-1.3	0.5	0.1	-1.0
TOTAL	Croplands	265	537	913	1170	1501	102.6	70.0	28.1	28.3	466.4

Source: Adapted from Richards (1990), p. 164.

Over the same period of landuse changes discussed here (i.e. 1700-1980), Global human population increased more than sevenfold, from 0.6 billion to 4.43 billion, causing much pressure on resources (Adger & Brown 1994). Generally, landuse change is a continuous process, evolving process, and is the single most important manifestation of human interaction with the biosphere. The scale and rate of change of landuse is greater now than at any time in history due to rapid technological change and population growth. Landuse practices and landuse change play an important contributory role in the human impact on natural forests, the environment and ultimately on the whole biosphere.

2.3 Sustained Management and optimal utilization of tropical rainforests.

Sharma (1992) identifies three general principles which normally form the theoretical basis for management systems of tropical forest systems. These are: (i) measuring in social terms the costs and benefits for the society as a whole; (ii) identification of all potential uses, the interest groups and the interaction between them; (iii) including the time perspective (i.e. consideration to future needs). Such a management system for forest resource exploitation can be achieved in two principle ways: (a) By managing the forest as a renewable resource hence aiming at sustained yield from the resource. (b) By "mining the forest resource (i.e. managing the forest as a non-renewable or exhaustible resource). The latter leads to resource degradation and depletion effects such as deforestation. The management of the forest resources in the Nguru mountains is focused on sustainable management. Consequently, this review will not deal with optimal exploitation of exhaustible resources, a subject dealt widely by several authors such as Solow (1974), Schulze (1974), Fisher (1981), Miller and Upton (1985), Fisher & Hanemann (1986) among others. The tropical rainforest need to be managed and exploited optimally. The models for optimal exploitation of such a resource require that biological and economic knowledge are combined to foster the highest possible sustained output from a human point of view (Clark 1976, Sødal 1988; Pearce & Turner 1990). In this context, Maximum Sustained Yield is defined according to Pearce & Turner (1990) as the highest possible biological output from a renewable resource which can be extracted repeatedly without decreasing the stock in the long run. This occurs when the growth rate reaches its maximum. However, Maximum sustained yield is considered not an optimal management policy because of the costs of harvesting which are a function of the effort used and the stock level. Thus to arrive at the socially maximal output, costs and revenues are also introduced.

Normative analysis shows that, the maximum sustained yield is not optimal when harvesting costs are considered in a static environment (i.e discount rates are not considered). This theoretical model underscores the point that under normal conditions, maximum social profit is realized only if effort is restricted and this can be achieved by introducing property rights to the resource or to tax the use of the resource (Pearce & Turner 1990). The role of property rights in shaping forest resource utilization is the subject of the next section. However, it is important to note that a dynamic model for resource utilization introduces the discount factor. For the user of the forest resource, the discount factor equals the highest output rate of the alternative uses of the capital invested (*op.cit.*). Hence, a high discount rate means that there is a high demand for the forest

resource benefits on the short term. This also implies a short time perspective, which is not in favour of sustainable forest management or forest conservation objectives.

2.4 Property rights and forest resource utilization

The success of sustainable management of forest resources depends partly on the way incentives for sustainable behaviour are instituted among the different users of the forest resource (Pearce & Turner 1990). Destructive deforestation and land degradation have been occurring rapidly in recent decades because market and policy failures provide strong incentives to exploit forests (Sharma 1992). Market failures stem from undefined property rights to certain aspects of land and forests, both within a particular time period and between the present and the future (*ibid.*). One of the basic issues tailored to incentives for sound forest and land management practices is the question of property rights. Understanding of property rights and the rules used to create and enforce them, is important to shape perceptions of resource degradation problems and the prescriptions recommended to solve such problems (Schlager & Ostrom 1992). The ambiguous property rights blur analytical and prescriptive clarity. Thus to achieve efficiency, property rights must be well defined, exclusive, secure, enforceable, and transferable (Sharma 1992). Schlager & Ostrom (1992) cite the term "common-property resource" as a glaring example of a term frequently used to refer to varying empirical situations. It may refer to: (i) property owned by a Government; (ii) property owned by no one; and (iii) property owned and defended by a community of resource users. The term is also used to refer to any common-pool resource used by multiple individuals regardless of the type of property rights involved (*op.cit.*).

In regard to common-pool resources, the most relevant operational level property rights are "access" and "withdrawal" rights which are defined as follows: (i) access is the right to enter a defined physical property; (ii) withdrawal is the right to obtain the products of a resource (*op.cit.*). Moreover, common-pool resources are also associated with collective-choice property rights which include management, exclusion and alienation. Management refer to the right to regulate internal use patterns and transform the resource by making improvements. Exclusion refers to the right to determine who will have an access right, and how that right may be transferred. Alienation means the right to sell or lease either or both of the above collective-choice rights. The purpose of this section therefore, is to outline some theoretical aspects of property rights and their impact on land and forest resource utilization in general.

2.4.1 Context of property rights

According to Schlager and Ostrom (1992), the terms "rights" and "rules" are frequently used interchangeably in referring to uses made of natural resources. However, clarity in analysis is enhanced by realizing that "rights" are the product of "rules" and thus not equivalent to "rules". "Rights" refer to particular actions that are authorized whereas "Rules" refer to the prescriptions that create authorizations. Thus a "property right" is the authority to undertake particular actions related to a specific domain (Commons 1968). Randall (1987) defines property rights as the exclusive right to control, use and receive benefits from a resource. Therefore, for every right an individual holds, rules exist that authorize or require particular actions in exercising that property

right. All rights have complementary duties, and to possess a right implies that, someone else has a commensurate duty to observe this right. Thus rules specify both rights and duties (Schlager & Ostrom 1992). Property rights range from authorized user, to claimant, to proprietor, and to owner. All these categories of property rights, face incentives that are frequently substantial enough to encourage long-term investments in the improvement of resource systems (*ibid.*).

Property rights may also be *de facto* or *de jure* (*ibid.*). This distinction emanates from the sources of the rights of access, withdrawal, management, exclusion and transfer. When property rights originate from the Government whose officials explicitly grant such rights to resource users, such rights are *de jure* rights in that they are given lawful recognition by formal, legal instrumentalities. Rights holders who have *de jure* rights can presume that if their rights were challenged in an administrative or judicial setting, their rights would most likely be sustained. Property rights may also originate among resource users. In some situations resource users cooperate to define and enforce rights among themselves. Such rights are *de facto* as long as they are not recognized by Government authorities. Users of a resource who have developed *de facto* rights, act as if they have *de jure* rights by enforcing these rights among themselves. In some settings, *de facto* rights may eventually be given recognition in courts of law if challenged, but until so recognized they are less secure than *de jure* rights. Within a single common-pool resource situation a conglomeration of *de jure* and *de facto* property rights may exist which overlap, complement, or even conflict with one another (*ibid.*).

Randall (1987) identifies four criteria for a non-attenuated property rights regime. These criteria are (i) complete specification; (ii) exclusivity; (iii) transferability and; (iv) enforceability. However, in practice, property rights are very seldom absolute. They are often circumscribed in some way by the generally accepted rules of the society, hence they are attenuated. Bromley (1991) advances four levels of property rights that can be recognized. These are as follows: (a) state-owned property regimes; (b) private property regimes; (c) common property regimes, i.e. private property for a group of co-owners; (d) non-property regimes, i.e. open access. From the viewpoint of management, two important aspects ascribe to property rights. These are: (i) revenue collection; (ii) resource use. For a renewable resource like a forest, benefits are realized by the owner if he secures existence and regeneration of the forest.

2.4.2 Property rights and revenue collection from resource users

Forests are a source of a variety of benefits whose utilization require the use of labour and capital. Under perfect competitive market conditions, these together with land, are allocated such that no additional benefit can be gained by changing their distribution. One aim of the forest owner is to gain profit, which is the difference between benefits and costs. In the resource management context, it refers to the resources's ability to generate an output for the forest property owner in addition to what must be paid for the use of labour and capital (Skage & Næss 1994). If the forest is state-owned, the benefits should be distributed equitably within the society. The royalties (stumpage fee paid to get permission to use a standing tree) are therefore not a cost factor, but rather a production result or the value of the production factor generated by what Ricardo referred to as "the indestructible powers of soil" (*op.cit.*). A forest product consumer

should therefore pay to the owner, for using the natural resource (i.e. the tree), like he pays for using labour and capital. The resulting revenue collections should be captured by the society in case of a state-owned forest property. This revenue is essential to facilitate forest management and control of exploitation both at local and Government level. In the absence of revenue collection from the use of a forest resource, forest management activities will slack, leading to dilapidated forest condition as it seems to be the case with the tropical rainforest in the Nguru mountains.

.2.4.3 Property rights and sustainable forest management

Different bundles of property rights, whether they are *de facto* or *de jure*, affect the incentives individuals face, the types of actions they take, and the outcomes they achieve. An ideal property rights regime gives the owner, incentives for efficient resource allocation in the meaning that, the available input factors (labour and capital) are used so that it gives the highest possible output. Since failure to do so results in a lower output and a loss for the owner, it is a very strong incentive for efficient resource allocation and sustainable management. The role of property rights in resource management and utilization is very crucial, because the lack of some basic characteristics of property rights such as proper definition, exclusiveness, security, enforceability, and transferability in local land markets, is probably the single most important cause of problems related to forest products for local consumption such as fuelwood (Sharma 1992). Property rights problems are also the root cause of the environmental problems and fuelwood scarcity associated with deforestation, and ill-defined property rights provide pervasive disincentives against tree growing (*ibid.*). Private property rights that are ill-defined or attenuated also contribute to forest product scarcity and provide obstacles to implementing successful fuelwood projects, especially those based on encouraging small farmers to use agroforestry systems or otherwise grow trees for local use. Insecure land tenure reduces investment incentives and encourages preference for current consumption over future consumption (Feder *et al.* 1988).

A number of recent attempts to move land tenure from centralized control to more local or private control have demonstrated the efficiency gains that are possible (Spears 1988, Sharma 1992). However, the specific property rights regime that should be implemented will vary for individual locations and situations. Privatization may be best where land and production systems warrant individual or family investment. It may also be best when shifting cultivation or other agricultural practices have already resulted in *de facto* privatization. However, privatization may not be best when the land area is extensive and cannot be protected from outsiders, when the value of production is too low to warrant individual investments, and when products are diverse and used by a variety of people, except when the products are of high cash value (Sharma 1992). In small, self-sustaining rural communities, where strong traditions of community or tribal management of resources exist, and where population and other external pressures are mild, community management of forest resources such as fuelwood resources may be appropriate. Indeed, traditional common property systems have been used successfully throughout history to manage resources on a sustained basis (Ciriacy-Wantrup & Bishop 1975, Runge 1981). Government ownership and control of forest resources for local consumption also can be efficient under certain conditions.

The issue in resource management, is not so much that any particular group should manage the resource, but that the group should be able to restrict access and have the necessary human resources available to manage the resource, and that either the land or the proceeds from the land should be distributed equitably among the affected people (Sharma 1992). The classification of traditional common property rights based on customary land tenure arrangements and impacts on resource use are analyzed by Hughes (1972 & 1974) based on studies in Swaziland and Zimbabwe. Beginning with the "rights of avail" he notes that "held by the community as a whole but in which every member of that community automatically participates. From this participation (one might say from this share of the "right of avail") flows the rights to make use of what the group considers to be a reasonable use of the natural resources available to the community, including land" (Hughes 1972, p. 62). From this right of avail, each group member derives other rights: the right of accommodation, right of tillage, right of pasture, right of water, right of stover, right to hunt, right of way, right to delve, right to collect. However, none of these in themselves establishes a firm legal relationship between an individual or family group and a particular parcel of land. Actual occupation (of residential site) or cultivation (of arable lands) is necessary to change these "preferential rights" into the complex of rights that Holleman (1949, p. 37, in Low 1986) has called "Bantu ownership". "Bantu ownership" includes the right to possess the land, the right to exclude other members of the community from making use, without permission, of any land over which Bantu ownership has been acquired. However, it does not include the right to alienate the land to those who are not members of that land-holding community. Furthermore, ownership can be lost through prolonged failure to use the land and that, continued ownership is entirely dependent on continued acceptance as a full member of the community (Low 1986). According to Schlager & Ostrom (1992) an important difference often discussed in economics is that between property owners, who hold a complete set of rights, and all other users who do not hold complete rights. In particular, the right of alienation is believed crucial for the efficient use of resources. Alienation rights, combined with rights of exclusion, produce incentives for owners to undertake long-term investments in a resource. Through the sale or lease of all or part of the property rights owners hold, they can capture the benefits produced by long term investments. In addition, alienation permits a resource to be shifted from a less productive to a more productive use (Posner 1975). Ownership, however, does not guarantee the survival of a resource such as a forest. If owners use a relatively high discount rate, they may still destroy a resource, whether forest or other (Clark 1976) or engage in activities leading to substantial overexploitation, resource abuse, and overcapitalization (van Ginkel 1989, Bromley & Cernea 1989).

Owners of natural resources such as forests, often invest in the physical structure of resources that maintain or increase the productivity of the resource. Besides rights of alienation, another important distinction among rights-holders is that between claimants and authorized users on the one hand, and proprietors and owners on the other hand, based on the rights of exclusion. The rights of exclusion produces strong incentives for owners and proprietors to make current investments in resources. Because proprietors and owners can decide who can and cannot enter a resource, they can capture for themselves and for their offspring the benefits from investments they undertake in a resource. Posner (1975) notes that owners and proprietors are reasonably assured of being rewarded for incurring the costs of investment. Such investments are likely to

take the form of devising withdrawal rights that coordinate the harvesting activities of groups of owners or proprietors so as to avoid or resolve common-pool resource dilemmas. In addition, owners and proprietors devise access rights that allow them to capture the benefits produced by the withdrawal rights (Dahlman 1980).

Claimants, because of their rights of management, face stronger incentives than do authorized users to invest in governance structures for their resources even though their incentives are weaker than proprietors or owners. Claimants can devise operational - level rights of withdrawal for their situation. Without collective-choice rights of exclusion, however, they can no longer be assured of being rewarded for investing in withdrawal rights. Consequently, whether claimants exercise their rights of management depends upon whether they act within a set of circumstances that allows them to capture the benefits of coordinating their activities even without rights of exclusion. For instance, claimants may utilize resources that no other groups are interested in using, or claimants may be physically isolated from other populations so that exclusion is not problematic. In such situations, claimants are likely to be able to capture the benefits from exercising their rights of management. Finally, authorized users possess no authority to devise their own rules of access and withdrawal. Their outcomes are dependent primarily upon the operational level rights that others define for them. Whether the incentives they face induce them to act so as to achieve efficient outcomes, depends upon the institutional design skills of those who hold the collective-choice rights. Since authorized users do not design the rules they are expected to follow, they are less likely to agree to the necessity and legitimacy of the rules. Authorized users may engage in a game with rule enforcers, seeking to gain as much as possible. This leads to an overinvestment and may lead to inefficient outcomes.

In conclusion, under various property regimes, sustainability in resource management can only be achieved if the property owner takes into account all relevant social benefits and cost factors involved. The owner, besides blind faith in private ownership, common-property institutions, or Government intervention, need to understand (i) the conditions that enhance or detract from the emergence of more efficient property-rights regimes related to diverse resources; (ii) the stability or instability of these systems when challenged by various types of exogenous or endogenous changes; and (iii) the costs of enforcing regulations that are not agreed upon by those involved. Further, the performance of property-rights regimes in field settings need to be compared to other regimes in field settings. No real-world institutions can win in a contest against idealized institutions. The valid question is, how various types of institutional arrangements perform comparatively, when confronted with similarly difficult environments.

2.4.4 "Open access" resource use, "the tragedy of the commons" and property rights

The mismanagement of tropical forests (for most part not managed at all) has been voiced in recent times by WCED (1987), Sharma (1992), WRI, IUCN & UNEP (1992) among others. One main cause is the inappropriate institutional arrangements for property rights regarding the tropical forests (Panayotou & Ashton 1992). The biggest problem related to property rights regimes and tropical forests, is the lack of ability to enforce state-ownership of tropical forests. In a situation with substantial rural population pressure and vast areas of state ownership which

are not being properly enforced as in the Nguru mountains, the areas are likely to end up in a situation similar to "non-property" or "open access" whose one main outcome, is resource degradation due to mismanagement and overexploitation. The open-access nature of forest lands in developing countries is probably the most significant impediment to solving land and forest conservation problems (Sharma 1992).

In order to avoid a "non-property" situation forest resources must be owned by an entity - a state, community or an individual (private owner) - or else they will suffer from a situation described by Hardin (1968) as "the tragedy of the commons". This situation is characterized by absence of restrictions or control over the use of the resource, hence "open access", and "the rule of capture is the only rational management rule" (Panayotou & Ashton 1992, p. 209). Hardin defined (mistakenly) common property resources as unmanaged, "open access", no-man's land, inevitably doomed to degradation as each individual withdrew more of the resource than would be optimal from the perspective of the user's as a whole. Ironically, what he was addressing was "open access" and not common property resource management, which implies, collective resource management systems (Unasyuva 1995). Hardin has already modified his position to rectify his oversight in a more recent work in which he argues that, the "tragedy of the commons" is inevitable only in a situation characterized by the absence of management. He also distinguishes between unmanaged and managed commons resources (Hardin 1994). "Common property" is used to refer to a property rights arrangement in which a group of resource users share rights and duties towards a resource (McKean & Ostrom 1995). There is property rather than non-property rights and these are common, not to all, but to a specified group of users. Therefore, common property is not access open to all, but access limited to a specific group of users who hold their rights in common (Runge 1981, Bromley & Cernea 1989). It is also important to note that of the four types of property: public, private, common and open access, common property is shared private property and subscribes to private property attributes (McKean & Ostrom 1995). Under open access, there are no formal or informal institutions restricting the use of a resource, hence it is optimal for each user, to utilize the resource values as long as there is private profit of using one more unit of the resource. Not to do so means that the profit is left to others, and the incentive for long-term planning is non-existent (Skage & Næss 1994). In consequence, common users tend to derive for themselves, as much profit from the resource as they can and in consequence, deplete the resource. Open access works well only when there is little need to manage a resource at all: when demand is too low to make the effort worthwhile (McKean & Ostrom 1995).

In resource-economy perspective, open access means that the resource is overutilized with the following economical and ecological implications: (a) Economical: The "tragedy of the commons" means that all the profits from the resource are lost because of excessive use of labour and capital. (b) Ecological: The effects on the resource itself will depend on the private utilization costs. If the resource is easily accessible and utilization costs are small, the resource is likely to be depleted for the resource values. Total degradation of the forest resource occur if there is a lower limit for the forest resource's ability to regenerate, and if the value of the resource are high relative to the costs (Sødal 1988). Hardin paper (and its prevailing argument, echoed and elaborated in numerous subsequent publications), have had a powerful influence in promoting

policies in favour of individual privatization or Government appropriation and management of common property natural resources, including forest land and trees (Unasylva 1995). It has also helped to focus the attention of an entire generation of social scientists on the challenge of resource degradation and the role of local communities in sustainable management. In many developing countries including Tanzania, Governments have put large tracts of forest land under Government control (institutionalized arrangement) by creation of Forest Reserves intended to protect forest resources. Unfortunately, the resources nationalized by Governments often were not open access resources, but rather, shared private property which was carefully managed by local communities through internally coherent rules that regulated use and controlled access. In a paradoxical situation, by assuming ownership and responsibility for resource management, Governments have caused many of these common property management systems to break down, creating in fact the very type of open access situations they were intended to control (*op.cit.*).

According to Unasylva (1995), there are circumstances where common property regimes are the most appropriate form of forest resource management—a self-reliant, participatory approach that provides sustainable benefits and ensures resource conservation. Hence it would be a grave mistake, to dismiss common property regimes as relics of the past, intrinsically unworkable or incompatible with contemporary society (McKean & Ostrom 1995). In the Nguru mountains, Forest Reserves were also created. However, due to peoples heavy dependence on forest resources, they still reap many benefits from the tropical rainforest and these are high relative to the costs of extraction. Coupled with poor control, the net result is the tendency to overuse the forest, leading to degradation of the resource. If this situation is allowed to continue unabated, it will result into loss of currently enjoyed economic benefits in the long-term.

2.4.5 Property rights when externalities exist and effect on forest management

Property rights over a resource are often associated with externalities either positive or negative. Gregory (1987), defines "externalities" as either costs or benefits that do not enter into the financial accounting system of the firm or the industry. One way to make resource users as well as the consumers to get information of the social costs and benefits through the price system, is to "internalize" the effects (i.e. including these effects) in the accounting system of the firm or industry (*ibid.*). According to Randall (1987), there are various discussion aspects concerning this issue. One is to assume a situation where there is a negative externality and that only two parties are involved: the acting party (the one creating the externality) and the affected party (the one experiencing a loss of welfare due to the externality). One solution is for the acting party to pay compensation to the affected party equalling the externality. The other is for the affected party, to "bribe" the acting party in order to reduce the level of the externality. How property rights are defined will determine which of these solutions will be chosen. If the acting party has the rights, the second solution is chosen. If the acting party has no rights, they have to take into account the effect of their activity. An institutional alternative to this series of bilateral exchanges, is to create a common property regime to make resource management decisions jointly such as in community participation programmes in forest management (McKean & Ostrom 1995). Common property regimes may become a desirable option when, more intensive resource use, multiplies externalities between parcels and increases collective agreement on fairly restrictive use rules,

and when collective enforcement of those rules becomes easier than endless one-on-one deals (*op.cit.*). There are certainly many problems when it comes to quantification of externalities and enforcement of property rights. Either way, the optimal approach is to reduce the externality to a point where, the social gains of reducing the externality equals the social costs of reducing it (Randall 1987). The Forest Reserve has both positive and negative externalities. Positively, there are benefits such as climate amelioration, carbon sequestration and water supply to neighbouring areas. Negatively, it may harbour vermin, denies local communities potential agricultural land and other restrictions and may lead to their conviction when they breach forest laws. The multiple use of the forest is one source of the externalities associated with the forest resource. In practice, forests are managed for sustained yield of products. At the extreme, is the multiple use concept, which aims at finding the optimal balance between all potential uses.

The major objective of the multiple use model for sustainable management of forest resources, is to maximize net present social value of the forest land, and to find an "optimal mix" of potential uses through determining social costs and benefits. Panayotou & Ashton (1992) state that management problems are likely to arise because multiple uses of one forest area also may involve: (i) multiple users (ii) multiple and conflicting objectives (iii) multiple time frames (iv) negative interactions among uses. A number of factors must be considered, including: economic, physical, ecological, institutional, social and political. Based on economic theory, the multiple use model, employs social profitability to decide the value of each of the different potential uses. Social profitability means that, the social value of all benefits exceeds the costs. Thus cost benefit analysis can be used to find the social profitability in practice, and can also be used to compare different management systems with regard to social profitability. A brief review of Cost-benefit analysis is given in Monela (1995c). Two potential problems related to sustainable forest management which arise when using this method are: (a) It is difficult to identify and quantify social values, and it is difficult to choose the appropriate discount rate for the future benefits and costs. (b) Costs and benefits are distributed unevenly in time and space and the consequence of this is that: (i) securing the resource in the long-term will often mean restrictions on short-term access to the resource; (ii) poor people in rural areas have high preferences for utilization of the resource now, and even if conservation measures may prove beneficial for them in the future, they are likely to suffer most from restricted access; (iii) the benefits, for instance, of conserving biodiversity, will be received by the whole international community, while the local people must pay the costs through restricted access to the resources. It is due to such constraints that, despite efforts to conserve forest resources, degradation and deforestation pressure are still important problems in tropical rainforests. This is an important subject discussed in the next section.

2.5 Review of forest degradation and deforestation

2.5.1 Context of forest degradation and Deforestation

According to WCED (1987), forests are a vital factor in maintaining environmental quality. They are also one of the four major biological systems that directly and indirectly supply food to mankind, the other three being grassland, cropland and fisheries. The tropical rainforests are reservoirs of rich genetic resources. The direct commercial value and indirect benefit of forests

is very high and ever-increasing (Munasinghe 1992). It is this property of rainforests that has attracted the profit seekers as well as the local people to over-exploit the forest and threaten it through deforestation pressure and degradation. According to the definition used in the FAO 1990 Forest Resource Assessment, "deforestation" refers to a change of landuse with the depletion of tree crown cover to less than 10 percent (Adger & Brown 1994). A more recent definition adopted in the present study is given by Grainger (1993), who defines "deforestation" as the temporary or permanent clearance of forest for agriculture or other purposes. The key word here is clearance such that, the forest has to be cleared and replaced by another landuse. If forest is not cleared then deforestation does not take place (*op.cit.*). Deforestation is therefore a dynamic process which physically and biologically, degrades the forest ecosystem and sometimes irreversibly with disastrous social, economic and political consequences. Such consequences manifest themselves in form of genetic depletion of the valuable species, mechanical damages of trees, flooding, erosion, loss of vegetation cover, increasing wood supply distances and sociological consequences such as ever-increasing urbanization, as people cannot adequately sustain themselves in rural areas (WCED 1987, Sharma 1992). Deforestation is a widely used term and sometimes can have different meanings in different contexts. Disturbance deforestation, refers to all man-made disturbances that seriously alter a forest; Conversion deforestation, refers to man-made disturbances that subsequently convert forest lands to alternative uses. Many man-made disturbances, however, permit land to remain in forest use. Wasteful (or destructive) deforestation depletes forests and replaces them with alternative uses that yield lower-value goods and services (Sharma 1992).

In the tropics, clearfelling constitutes deforestation but it is rare (Grainger 1993). The common forestry practice is selective logging. This does not cause deforestation since it removes only a few trees per hectare and leaves the rest behind. However, some trees are damaged, forest structure is temporarily changed when the canopy is disturbed and there are also changes in biomass and species composition. Many of these changes will be reversed over time as forest regenerates, but they are changes nonetheless. Selective logging and other lesser impacts should not be ignored but should be defined in the correct context. For those concerned with specific effects of human impacts such as on biodiversity, the difference between logging and deforestation is absolutely crucial. In this context, it becomes important to distinguish between deforestation and degradation. Degradation is defined by Grainger (1993), as a temporary or permanent deterioration in the density or structure of vegetation cover or its species composition. This encompasses the effects of selective logging, which causes temporary change in canopy cover, forest structure, biomass and species composition and lowers productive capacity. Degradation in which the density of vegetation is reduced to zero is obviously the most extreme, leading to deforestation (*op.cit.*). In most developing countries, due to rapidly increasing population pressure, more and more land is needed for agriculture and more and more wood for fuel. Consequently, the world's wooded lands are being deforested and degraded at a scale never seen before in human history (Sharma 1992). Deforestation and land degradation, largely interlinked, have become a worldwide problem carrying a high cost to the development effort (Munslow *et al.* 1988) - a symptom of man's incompetent dealing with the earth's living resources (Munasinghe 1992). The fate of the tropical forests and woodlands is one of the major environmental issues of today, attracting more attention than ever before (*ibid.*).

The concept of deforestation and development are strongly interlinked. Paradoxically, in the Third World, when forests are cleared for just about any purpose they are said to be cleared for "development". On the other hand, the concept of development has recently been broadened to include, *inter alia*, environment aspects, such as high forest cover or sustainable management of forests. Accordingly, protection of forest from deforestation, conservation and deceleration of deforestation have become legitimate objectives of national and international development efforts (WCED 1987). Development is adopted here as a process of co-evolution with the changing forest environment, while itself being a source of environmental change. Therefore, deforestation is viewed as being closely linked with development. In countries with relatively high forest cover initial clearing to mobilize development is often unavoidable, when economic development implies structural transformation within the economy (Adger & Brown 1994). Depletion of forests is most significant in the tropics, where many people depend on natural forest resources for many economic and environmental goods and services (*op. cit.*). Social, economic and political factors have created incentives for rapid exploitation of forests and intensified pressure on remaining tropical forests and arid woodlands (Sharma 1992). Estimates by FAO/UNEP show that between 1980 and 1985, the annual rate of tropical deforestation was 0.6 percent or 11.4 million hectares, while recent studies estimate deforestation in the tropics at a rate of 17 to 20 million hectares annually (*op. cit.*).

2.5.2 The problem of deforestation and degradation

Forests account for almost 30 percent of the earth's total land area. (Sharma 1992). People throughout the world are increasingly recognizing the importance of forests and trees in improving human welfare. In recent years, the pace of deforestation has been increasing because there are strong incentives to exploit forests. Deforestation in the tropics is now estimated at nearly 20 million hectares annually (Sharma 1992). Many developing countries face acute shortage of fuelwood, fodder, timber and other forest products. Atmospheric pollution threatens temperate forests in many industrialized countries, while many tropical and temperate areas lack forests altogether. By the year 2000 the world population will increase by one billion, with developing countries accounting for most of the increase (Sharma 1992). This rise in population, coupled with a rise in income, will increase demand for both market and non market forest goods and services, and that demand will place more pressure on existing forests, particularly in developing countries. Deforestation in the tropics is expected to continue to be significant throughout the 1990's (*op.cit.*).

The misuse of forests has other significant social, economic and environmental costs with local, national, and global implications. Depletion of forests has resulted in loss of biodiversity, possible global climate change, degradation of watersheds and desertification. In many countries, forest dwellers have been displaced and cultural diversity threatened. Reduced fuelwood supplies have significantly influenced how women and children (the primary fuel gatherers) spend their time. Deforestation, together with land degradation, exacerbates the problem of poverty in rural areas. Besides having adverse environmental and social consequences, wasteful deforestation generates economic losses, including the permanent depletion of a renewable resource, loss of genetic diversity, and reduction of agricultural productivity (Grainger 1993, Adger & Brown 1994).

2.5.3 Theoretical paradigms of development to explain factors underlying deforestation

The social conditions that are considered primary factors underlying Third World deforestation, tend to fall into recognized theoretical paradigms of development. Population increases are couched in terms of neo-Malthusian demographic pressure, contributing to land and resource scarcity. Issues of internal development and privatization of resources fall within the bounds of Modernization Theory, whereas global market pressures and influences tied to international lending practices, raise questions commonly asked within the bounds of the Dependency Theory. Mascarenhas (1991), pointed out that, although each of these perspectives contribute significantly to the understanding of social factors influencing deforestation, none adequately addresses the entire picture. For example, tenurial traditions and tax policies often provide incentives for inefficient and inappropriate forest land use leading to deforestation. Many of these underlying causes are related and because they are so often embedded in divergent social and economic context, their relative importance varies substantially among countries.

2.5.4 Theory of deforestation

Palo (1984), Palo & Salmi (1987) and Palo & Mery (1990) advance a provisional theory of deforestation as a vicious circle whereby, population growth along with consequent domestic demands, international demands and asymmetry as well as access roads appear as driving forces or external shocks in the causal system as shown in Figure 2.1. Environmental deterioration in the form of deforestation, soil erosion and other detrimental consequences, forest-based development and human depression compose the other key functional factors in this causal system. Planned control by Government and automatic control by market ("invisible hand") are two primary mechanisms often used to control socio-economic development toward social well-being within national economies. However, in the tropics both of them fail to control deforestation (Palo & Mery 1990). While Governments are neither motivated nor able to control deforestation through policy measures or coercion market mechanisms provide no negative feedback loops to check deforestation in the tropics (*ibid.*). In general, markets play a minor role in the distribution of forest-based commodities in developing countries. Moreover, they are often ineffective because of widespread market failures. Vaguely defined and unequitable land tenures add a complicating dimension. Property and tenure rights are systems of authority established by cultural traditions, colonial powers or national Governments and they form a set of right-to-control land assets. These strongly affect the bargaining powers of various parties and thereby the distribution of income and wealth (Palo & Salmi 1987). The rural poor, the main agents of degradation, are effectively prevented from borrowing from the credit markets in the absence of guarantees due to lack of tenure or uncertain tenure. In most developing countries, most publicly owned forests are an open access resource. Open access resources in the form of forests create more market failures (Pierce 1988). Under open access conditions increasing scarcity of forest does not raise its price sufficiently (if at all) in order to mobilize adequate management or substitution. Asymmetry and uncertain tenure conditions still prevail in developing countries. International asymmetry as explained by the "Dependency Theory" exacerbates the situation. All these situations compound the problem of deforestation (Palo & Mery 1990). The role of each factor is discussed more in the sections which follow.

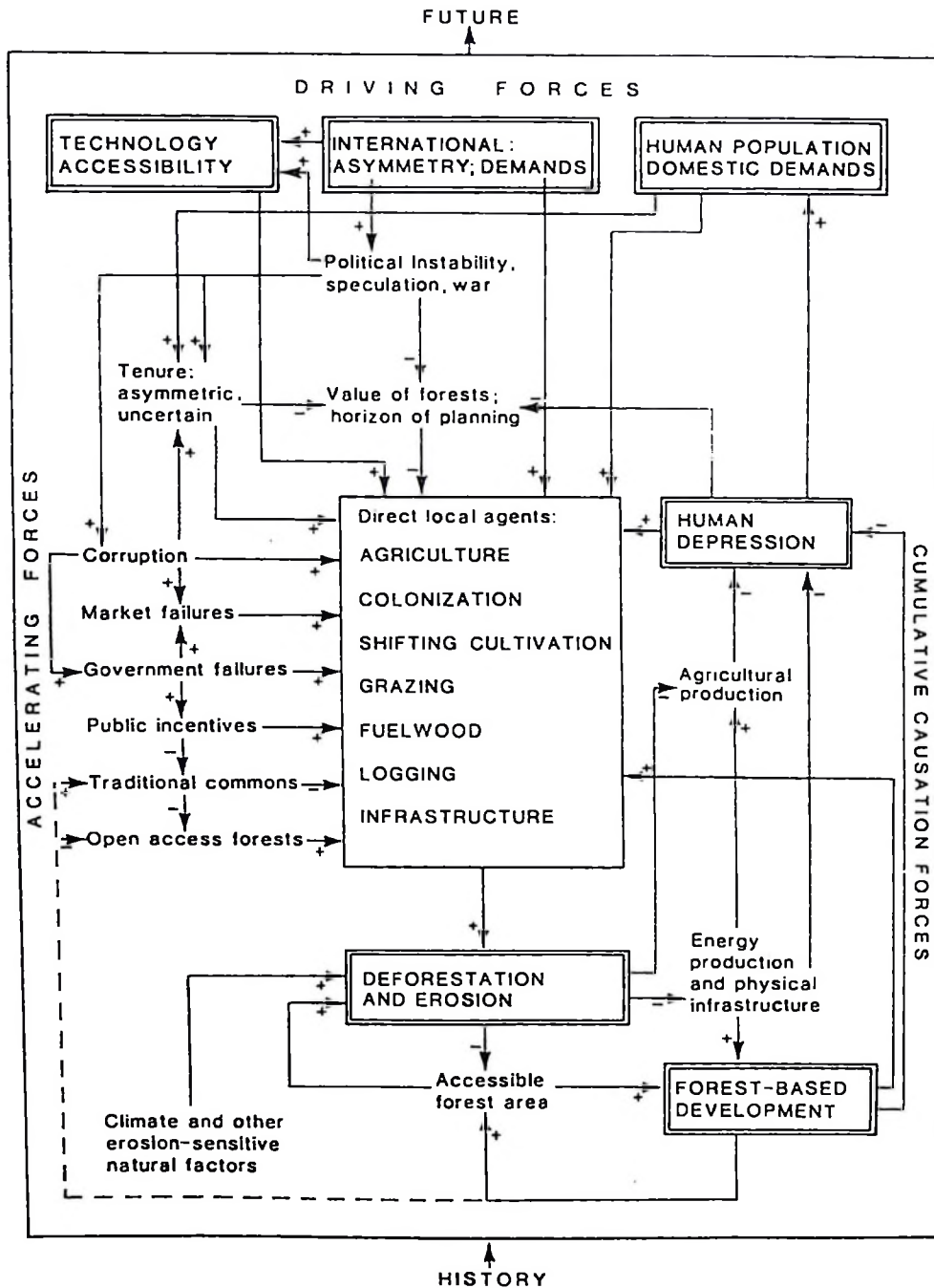

Figure 2.1. System causality of deforestation and regressive development process in developing countries (plus sign= positive feedback, negative sign = negative feedback)
 Source: Adapted from Palo (1990) p. 157.

2.5.5 The Gap Theory and estimation of deforestation dimensions and rates

Despite the threatening aspects of deforestation, the dimension of this phenomenon and numbers of people suffering from it are only vaguely known (Ahlback 1992). Many attempts, however, have been undertaken theoretically to determine the rate of tropical deforestation globally and in single countries. Over time, methods have changed, more information obtained and new trends in thinking evolved. The "Gap Theory" as stated by Leach and Mearns (1988), Munslow *et al.* (1988) and Dewees (1989) has been used for estimating deforestation rates. This has also been applied in Tanzania (Ahlback 1986, 1988 & 1992). It is based on the assumption that, the woodfuel crisis is a simple, direct problem of energy supply and demand, and that woodfuel consumption is the principal cause of deforestation and consequently, of mounting woodfuel scarcity. Until recently, this view has been encouraged even by the World Bank and other donor agencies and in consequence figures and conclusions based on this theory have been widely cited. The case in point is the 300 000 - 400 000 ha/year, often cited deforestation rate in Tanzania. This figure has been criticized in recent years (NEAP 1994 and NCSSD 1994).

The procedure used in the Gap Theory can be quoted from Leach and Mearns (1988) in Ahlback (1992) p. 94. "to measure the scale of this impact, one estimates the consumption of woodfuel (and sometimes of timber, construction poles and other tree products) in a given region and compares it with the standing stocks and annual growth of tree resources. The latter may be scaled down to allow for controlled Forest Reserves, Game Reserves, and trees in remote places where access is difficult. Typically one finds that consumption greatly exceeds the annual growth of trees..... The next step is to project these present-day gaps. Since consumption has to be met from somewhere, one assumes that the difference - the "gap" - is made up by cutting into tree stocks. Woodfuel consumption is projected, usually in direct proportion to population growth, and calculations are made of the resulting tree stock each year. As consumption rises and trees are felled, annual growth falls, the gap grows bigger, and the tree stock is still further depleted. Inevitably, the stock of trees declines at an accelerating rate towards a final woodfuel and forestry catastrophe when the last tree is cut for fuel.... The final step is to ask what must be done to close the gaps and bring consumption and tree resources into balance. With few exceptions, the answer is afforestation (or demand management by the dissemination of more efficient cooking stoves, etc.) on a staggering scale".

The gap theory therefore forecasts that, within not a long distant future, all accessible tropical forests and woodlands would disappear. In this context, the Gap Theory tends to greatly exaggerate and obscure the scope of the problem, leading to the "fuelwood trap" (Munslow *et al.* 1988) which is misleading. There is a need to distinguish between demand, latent demand, consumption and the extent to which current demands can be acceptably moderated without seriously affecting the household's access to basic human needs. This the gap theory analysts fail to do (Ahlback 1992). Instead, they focus on woodfuel and the symptoms of its scarcity. Too often argues Dewees (1989), this myopic focus has been the driving force behind many projects. Ideally, according to him, energy constraints to development must be evaluated by balancing energy consumption with other variables and costs which influence demand. According to Leach and Mearns (1988), the major flaws in the Gap Theory can be summarized as follows: "the basic

assumption that deforestation is mainly caused by woodfuel consumption; the weak available data in general used (concerning consumption as well as growing stock and yield of wood etc.); the usual neglect to consider the natural regrowth capacity after clearing; the usual assumption that wood consumption is rising in line with population (even while supplies dwindle to vanishing point); the large-scale aggregate perspectives obscuring the fact that the problems in question rather are small-scale location-specific ones; the exaggeration of the need of planned large-scale interventions; and so on. Moreover, besides tending to overestimate fuelwood collection as the main cause of deforestation, the Gap Theory also tends to overestimate the need for tree planting for fuel (Sawe and Leach 1988). It uses methodically low supply figures including only solid roundwood of trees of certain minimum dimension and only of such trees inside forests and woodlands, neglecting those outside. Hence neglected too, is the additional woody biomass of trees and brush, inside as well as outside forests and woodlands, possible to use for fuel. Also neglected, are the large quantities of stock cleared for agriculture mainly burnt for increased soil fertility or for other reasons - quantities which to a large extent instead could be used for fuel."

It is argued by Leach and Mearns (1988) that supply gaps so calculated do not occur in the real world. People have to cope as best they can, economizing on the use of woodfuel or turning to substitutes. In addition, fuelwood collection does normally not even cause deforestation in the strict sense of the term (i.e. complete removal of the trees), normally at most degradation of the tree cover (O'Keefe & Munslow 1988). Leach and Mearns (1988) conclude that until the gap theory, by better information, is put on a correct respectable footing, "it must be regarded as a dangerously misleading assessment and planning tool". Remote sensing and GIS-based techniques provide one better alternative to estimate deforestation". However, the Gap Theory, according to Dewees (1989) has served a valuable function "as a political tool which has successfully raised the awareness of development planners about the interdependencies between trees and people in developing economies. Projections it offers are politically powerful. Thus to conclude, the ideas about the nature of the fuelwood crisis are beginning to change fundamentally. It is more and more recognized that the problem is not only simple supply/demand question (Leach and Mearns 1988 and Dewees 1989). Many other factors are at work, such as labour wages, wood traders, make-ups, monopoly, transport systems, and so on (Palo 1990). However, there is a consensus that the problem exists and is real. In reality, there is no escaping the trend underlying the gap theory. What the projected gaps point towards is the rapid emergence of profound and deeply dangerous imbalance in the wood supply systems of the developing world.

2.5.6 Estimates of deforestation and landuse change data

Although forests are a stock of wealth, they are not directly measured over time as part of agricultural or landuse censuses (Adger & Brown 1994). Many deforestation estimates are therefore based on surveys, which in recent years have utilized remote-sensing techniques (Myers 1989, Grainger 1993). According to Adger and Brown (1994), data difficulties with deforestation rates are numerous globally. In addition to the definitional problems of forest categories, the technology of satellite imagery of rates of loss of forest cover also poses problems. The problems of satellite data collection, which is the only option for global scale data for detecting landuse

change, are formidable. Remote sensing such as Aerial Photography, which relies on solar and thermal wavelength, is weather dependent, though microwave sensors overcome this problem. All systems have difficulty in determining accurate deforestation rates especially where forest loss is through burning and where weather problems allow smoke particles and clouds respectively, to obscure the vegetation cover. Integration of landuse data to determine deforestation rates seems a better option which involves coordination of field surveys, satellite images and other data sources (Mather 1992, Bunce *et al.* 1992).

The first global analysis of deforestation was the 1980 FAO/UNEP Tropical Forest assessment. Completed in 1982, this aimed to provide the first comprehensive and statistically consistent assessment of forest resources, deforestation and afforestation, in tropical countries. Since the completion of the 1980 project, the need for a continuous process of global forest inventory has been made apparent, and a new assessment of tropical forests was initiated in 1990. This was intended to be part of an ongoing monitoring and data gathering process. The 1990 assessment consisted of two phases: the first was based on collation and analysis of existing information, and the second using remote sensing data from multigate high-resolution satellite (Singh 1993). This assessment overcomes many of the problems of comparability by issuing guidelines, published by FAO in 1990, and has developed a software programme known as Forest Resources Information System (FORIS) for use on personal computers and is designed for easy entry, retrieval and storage of data (Adger & Brown 1994).

Data from the 1990 Tropical Forest Assessment is presented in Table 2.2. This shows that total forest area in the tropics has decreased from 1910.4 million ha in 1980 to 1756.3 million ha in 1990; this represents a decline of 15.5 percent. Annual rates of decrease between 1981 and 1990 are calculated to be 0.7 percent in Africa, 1.1 percent in Asia and 0.7 percent in Latin America; equivalent to a decline of 0.8 percent for all tropical countries. Although comparisons are difficult because of changing definitions, deforestation rates may have been lower, probably running at annual rates of about 0.6 percent, in the 1970s (*op.cit.*).

Table 2.3 shows the current state of forest inventories in tropical countries. Only two out of 40 countries in Africa, and six of 33 in Latin America have conducted more than one inventory, and no assessment was available for three countries in Africa when the survey was carried out as part of the FAO 1990 Forest Assessment. Accurate country or regional historical data are clearly lacking for some parts of the world, and even when available, their accuracy may be highly questionable. Table 2.4 presents a comparison of various estimates of forest cover and deforestation by geographical subregions, from 1970 to 1990, as compiled by Grainger (1993). This comparison highlights serious discrepancies. First, it is not clear whether the estimates are strictly comparable, as they use different definitions of deforestation - be it total clearance, selective logging, or degradation - and also different types and categories of forest. Second, methodologies and techniques of measurement differ, and remote sensing has done little to provide more accurate data. Remote sensing techniques offer conflicting estimates, depending on resolution and sampling coverage (Adger & Brown 1994). For example, two estimates of deforestation in Brazilian Amazonia using remote sensing provide very different figures.

Table 2.2 Estimates of forest cover area and deforestation by geographical subregions

Geographic regions and subregions	Number of countries surveyed	Total land area (million ha)	Forest area (million ha)		Annually deforested area (million ha)	Rate of change 1981-1990 (% per annum)
			1980	1990		
Africa	40	2236.1	568.6	527.6	4.1	-0.7
West Sahelian Africa	9	528.0	43.7	40.8	0.3	-0.7
East Sahelian Africa	6	489.7	71.4	65.3	0.6	-0.8
West Africa	8	203.8	61.5	55.6	0.6	-0.8
Central Africa	6	398.3	215.5	204.1	1.1	-0.5
Tropical Southern Africa	10	558.1	159.3	145.9	1.3	-0.8
Insular Africa	1	58.2	17.1	15.8	0.1	-0.8
Asia	17	892.1	349.6	310.6	3.9	-1.1
South Asia	6	412.2	69.4	63.9	0.6	-0.8
Continental south-east Asia	5	190.2	88.4	75.2	1.3	-1.5
Insular south-east Asia	5	244.4	154.7	135.4	1.9	-1.2
Pacific Islands	1	45.3	37.1	36.0	0.1	-0.3
Latin America	33	1650.1	992.2	918.1	7.4	-0.7
Central America and Mexico	7	239.6	79.2	68.1	1.1	-1.4
Caribbean	19	69.0	48.3	47.1	0.1	-0.3
Tropical South America	7	1341.6	864.6	802.9	6.2	-0.7
Total Tropics	90	4778.3	1910.4	1756.3	15.4	-0.8

Source: Singh (1993).

Table 2.3. State of forest inventory in the tropics

Region	Number of countries surveyed	Number of countries with forest resources data at national level							
		No assessment	Forest area information		More than one assessment	Forest conservation and management	Forest plantations	Volume and biomass	Forest harvesting and utilisation
			Before 1980	1980-1990					
Africa	40	3	17	18	2	7	5	2	4
Asia and Pacific	17	0	1	5	11	9	8	8	7
Latin America and Caribbean	33	0	11	16	6	12	4	4	4
Total	90	3	29	39	19	28	17	14	15

Source: Singh 1993

At the Brazilian National Space Agency (INPE), one group estimated a deforestation rate of 1.7 million ha per year for the period 1978-1988, whereas another group at the same agency estimated 8.1 million ha per year for 1987. The discrepancies were a result of using different resolutions, and using different measures or indicators of deforestation (*op. cit.*).

Since accurate estimates wholly based on remote sensing measurement are not currently available, on-the-ground monitoring of forest areas or even of stand growth would presently be the only option to verify remote-sensed data. The reasons for ambiguities in the Brazilian estimates mirror the uncertainties for the whole assessment of tropical deforestation: errors of measurement and extrapolation including the interpretation of satellite imagery obscured by smoke from fires; different definitions of the boundaries of the study; and actual yearly differences due to weather conditions or policy changes (*op.cit.*). However, one emerging message from the more recent studies is that the rates of deforestation in the tropics have increased during the 1980s, increasing by 50-90 percent over the decade according to the most recent estimates of Myers and of FAO as presented earlier.

Table 2.4. Estimates of rates of deforestation in the humid tropics (million ha per year) *

Source	Date	Period	Total (million ha year ⁻¹)
Sommer	1976	1970s	11-15*
Myers	1980	1970s	7.5-20 [†]
Grainger	1983	1976-1980	6.1 [‡]
Myers	1989a	late 1980s	14.2
FAO	1990	1981-1990	16.8 [§]
FAO	1992	1981-1990	12.2 [¶]
FAO	1993	1981-1990	15.4 [¶]

Source: Adapted from Grainger (1993).

Footnote: *15 commonly quoted studies.

[†]7.5 a later revision.

[‡]cf. 7.3 for all tropics.

[§]interim estimate.

[¶]revised interim estimate presented to UNCED.

[¶]1990 Tropical Forest Assessment as reported by Singh (1993): figure for all tropics.

Concerning African deforestation, the landuse change matrix for deforestation-related categories of land use between 1980 and 1980 is shown in Table 2.5. Forest cover in Africa, as shown in Table 2.2, is approximately 528 million ha, with deforestation running at approximately 4.1 million ha per year or 0.7 percent per year. The estimates of Singh (1993) are a preliminary report of the FAO 1990 assessment, so are said to await further data input (Adger & Brown 1994). As most large positive numbers in Table 2.5 are located above the leading diagonal, most observed changes are of loss of forest area, or of forest density. Permanent conversion to non-forest uses accounted for 16 percent of the total deforestation, with conversion to short fallow agriculture making up 34 percent of the change. Fragmented forest, a category of land increasing over the decade, occurs as a result of progressive clearing leading to a mosaic of forest and non-forest areas. Fragmented forest is an intermediate stage on the way to permanent agriculture. According to Singh (1993), this profile of the type of landuse change, a summary of which is presented in Figure 2.2, is an indication of spontaneous land use change, caused by population pressures in Africa. Although this seems intuitively plausible, the increasing agricultural use of former forest does not indicate an exclusively population pressure explanation of deforestation. The causal relationships for the analysis of how population pressure contributes forest degradation and deforestation are further discussed in section 2.5.7 and elsewhere in Monela (1995a).

Regarding landuse changes, Table 2.6 shows a generalized picture of landuse conversions by world region for the period 1977-1987. This table shows that North, South and Central America much of the forest area has been converted to pastureland during this period, whereas in Africa and Asia, most change is associated with other sorts of development, including roads, urbanization and probably degraded forest. What is also clear from Table 2.6 is that Africa, South America and Asia are undertaking net conversion from forest to other uses, whereas North and Central America; and Europe have experienced a net gain in forest area. This illustrates what Mather (1990) has referred to as the "Forest Transition", which postulates that the level of economic development and population density determine the demand for forest products and thus forest cover. The processes and agents causing the conversion of landuse include: Subsistence agriculture, cash cropping, cattle ranching, fuelwood, mining and other infrastructural and industrial development, and the trade in tropical timber (Myers 1994).

Most of landuse changes are a result of the competition for space between human and other species and this competition is demonstrated by the conversion of land to agriculture, infrastructure, urban development, industry and unsustainable forestry. The depletion of natural habitats and the expansion of agriculture concurs with the classic Malthusian thesis which predicted agricultural extensification with increasing human population. Malthus, in 1798, postulated a tendency for human populations to grow geometrically, but for the means of subsistence to grow only arithmetically (Adger & Brown 1994). The former will outstrip the latter over time, resulting in a "Malthusian crisis" (*op. cit.*). Globally, there is little to suggest that this thesis has been proven because although the extensification of agricultural landuse continues, at the same time intensification of production as postulated by Boserup (1965), and out-migration both occur.

Table 2.5. Forest cover change matrix for the tropical African region

Classes at year 1980	Area of classes at year 1990 (thousand ha)									Total at year 1980	
	Closed forest	Open forest	Forest + shifting cultivation	Fragmented forest	Shrub	Short fallow	Other land cover	Water	Plantation	(thousand ha)	(%)
Closed forest	16781	382	83	292	10	524	248	—	—	18 319	24
Open forest	24	10049	48	371	13	118	397	0	1	11 022	14
Forest + shifting cultivation	8	15	557	2	4	52	29	—	—	666	0
Fragmented forest	24	40	1	8089	8	6	294	—	—	8461	11
Shrubs	1	11	—	1	3878	—	164	0	—	4055	5
Short fallow	8	11	10	2	—	2255	53	0	—	2339	3
Other land cover	17	38	11	63	87	34	26452	51	—	26753	35
Water	1	—	—	1	0	3	82	2960	—	3046	4
Plantation	—	—	—	—	—	0	0	—	5	5	0
Total 1990	16863	10546	709	8820	3999	2992	27718	3012	6	74665	
Percentage of total land area	23	14	1	12	5	4	37	4	—		100

Source: Singh (1993).

Footnote: Totals may appear not to be exact due to rounding.

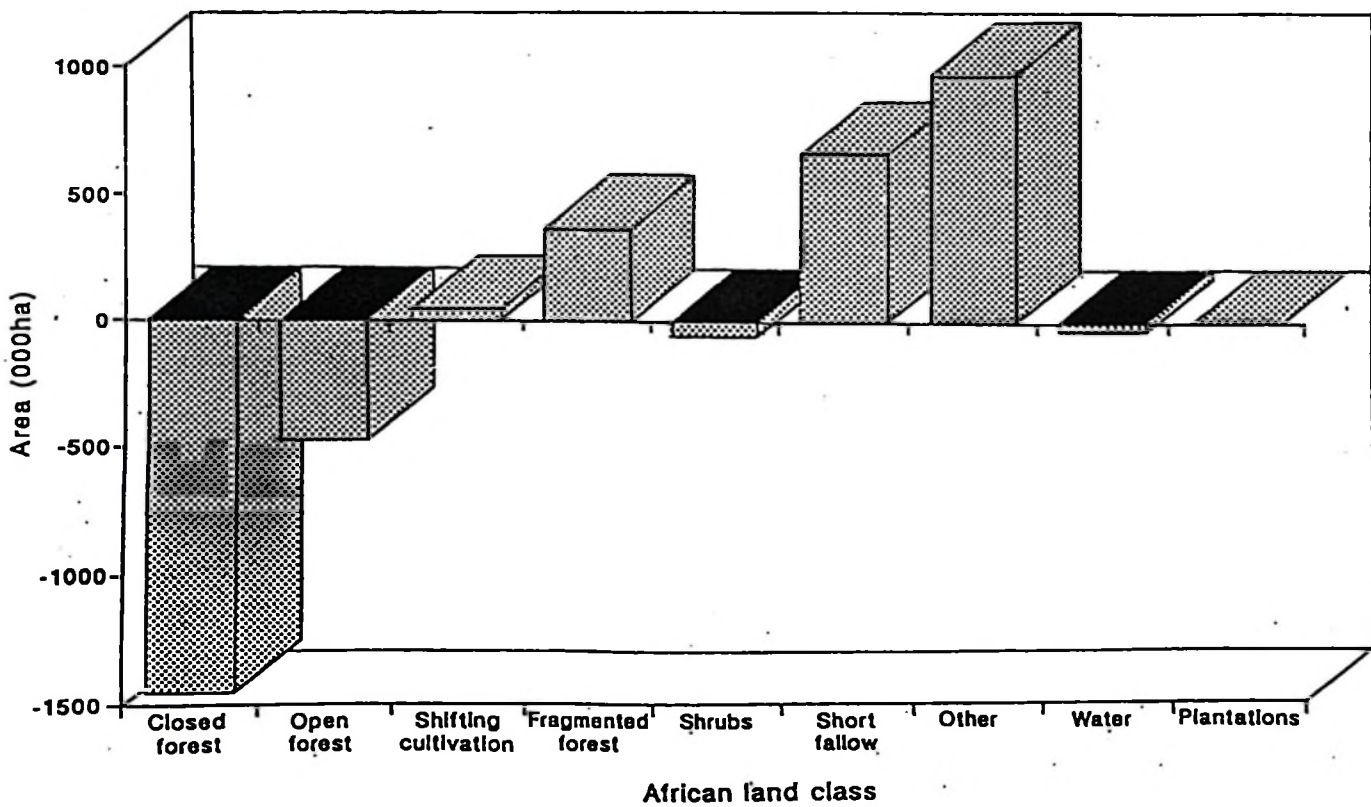

Figure 2.2. Change in land classes related to deforestation in Africa 1980-1990 ('000 ha).
Source: Adger & Brown (1994, p. 90), based on Singh (1993).

Table 2.6. Global land conversions 1977-1987.

	Cropland (million ha)	Pasture (million ha)	Forest (million ha)	Other (million ha)
Africa	+8	-4	-25	+22
North and Central America	+3	+11	+7	-20
South America	+14	+20	-41	+11
Asia	+4	-2	-29	+29
Europe	-2	-3	+2	+4

Source: Pearce and Brown (1994).

Footnote: Other land include roads, uncultivated land, wetlands, built-on land.

Moreover, the exact relation of these processes to environmental degradation, and especially deforestation, is still a subject of intense debate and is dependent on contributory factors such as property rights, particularly whether open access conditions operate (Adger & Brown 1994, Swanson 1994, Pearce & Brown 1994). The role of property rights has been discussed earlier whereas the various schools of thought on the role of population in deforestation is further discussed in the next section.

2.5.7 Socio-economic and landuse-related causes of deforestation in developing countries

2.5.7.1 System causality of deforestation

The causal analysis of deforestation in developing countries is based on an interdisciplinary system model and system causality (Palo 1990). The fundamental feature of this phenomenon is that the causal factors of deforestation are linked together as various chains or mechanisms into a causal system (Figure 2.1). The mechanisms comprise of positive feedback loops which accelerate deforestation. Inaccessibility of forests and successive reduction of forest areas constitute the only effective negative feedback loop (Palo 1990). The structure of the system causality has also been viewed as hierarchic in terms of international, national and local factors. The understanding of the nature and dynamic of deforestation as a physical as well as

a socio-economic process is essential for effective action in order to combat it because the causes are complex and vary widely, and in most cases several interacting factors are at work as shown in Figure 2.1. Some underlying causes originate outside the scope of forestry.

2.5.7.2 Direct causes and underlying factors

According to Palo (1990), Sharma (1992) and Grainger (1993) among others, the principle direct agents of deforestation in developing countries can be summarized as follows:

(i) Agricultural expansion and inappropriate agricultural practices (ii) Overgrazing (iii) Bush fires (iv) Excessive fuelwood gathering (v) Commercial logging (vi) Infrastructure and industrial development. These direct agents are a consequence of some underlying factors or causes.

The main underlying factors or causes of deforestation in developing countries include: (i) Market and policy failure (ii) Population growth and rural poverty (iii) State of the economy (iv) International asymmetry and demand. Generally, the accelerating conversion of tropical forests is occurring for a number of interlocking socio-economic and political reasons (Wood 1990). Alternatively they can be stated as: Inequitable land distribution, entrenched rural poverty, and growing populations which push landless and near-landless peasants onto forest lands; government-subsidized expansion into forests regions by plantations growing export crops, timber companies, and cattle ranches; and government-sponsored population relocation to frontier regions (Adger & Brown 1994).

The decisive indirect role of population growth

Population pressure plays a decisive indirect role as one of the driving forces in deforestation process (Palo 1993). Growing human population creates increasing domestic demands for food, energy, shelter and services of health and culture which again increase pressure on the various direct agents of deforestation either directly or via more asymmetric and uncertain tenure (*ibid.*).

Schools of thought on role of population on tropical deforestation

There have coexisted different schools of thought concerning the role of human population on economic development, environment and tropical deforestation. Malthus introduced his idea on population growing exponentially and food production only linearly two centuries ago. His scenario of the consequent human depression has been overcome by the progress of technology, sectorial transformation and rising real incomes. However, still the Neo-Malthusian tradition has remained vital particularly among biologists and ecologists (Palo 1993). Contrary to the former, Neo-Classical school of economics has considered population pressure either as neutral or beneficial to development. For the later, more people has meant more demand, more labor force, more talented brains and better technology, economies of scale and lower production and distribution costs. Deforestation and other environmental deterioration were assumed to be taken care of the competitive markets: if natural forests for instance would become economically scarce, their increasing real prices would induce more investments in forestry, hence the sustainability is maintained automatically (Woods 1987, Birdsall 1988, Boserup 1990). Poverty is one of the main underlying factors contributing to deforestation. The majority of rural poor rely

heavily on forests and woodlands for income and subsistence (WCED 1987). While traditional rural communities have developed comparatively sustainable forms of resource use, many others are compelled, by circumstances often beyond their control, to exploit forests unsustainably for short-term gain. At present, it is estimated that poverty affects about 1.1 billion people, 75 percent of whom live in rural areas (World Bank 1990).

2.5.8 Consequences of deforestation in developing countries.

Tropical forests maintain a number of functions which contribute to human welfare. Firstly, rural population is to a great extent directly dependent on its immediate environment for supply of water, food, energy, shelter and clothing, thus the deterioration of the environment could be expected to result in the stagnation or decline of the level of living standards. Secondly, the national economies in the non-oil developing countries are highly dependent on the production of primary commodities (World Bank 1990), thus unsustainable exploitation of the natural resource base undermines the prospect of future development in these countries.

The consequences of deforestation, can be defined as benefits or costs relative to their effect on human well-being. The profits of the new land use or the utilization of felled trees etc. are on the benefit side of deforestation. The costs of deforestation comprise the foregone goods and services notwithstanding, whether the losses occur on-site or off-site, immediately or in the future.

In general the negative consequences of deforestation include: (i) economic impacts; (ii) social impacts; (iii) environmental impacts; (iv) loss of biodiversity; (v) climate change; (vi) desertification; and (vii) watershed degradation.

2.5.9 Efforts to arrest deforestation in developing countries

According to Beets (1990) efforts to improve the welfare of the poor must be based on protection and restoration of the environment as a central tenet of Government intervention.

Among the intervention methods include: (i) population stability; (ii) policy reforms; (iii) soil conservation measures; (iv) reconciling wood supply and demand aspects; (v) tree planting; (vi) conservation and management of natural forests and woodlands.

2.5.9.1 Current Policy: Need for change to foster integrity and stability of forest ecosystems

According to Sharma (1992), market and policy failures provide strong incentive to exploit forests hence causing destructive deforestation and land degradation in most developing countries. Since there is always a conflict of interest between private decisions and society's preferences, markets must deal with long term periods for private decisions to reflect society's preferences. Although correcting these market failures would be one approach to forest policy that Governments would take, this approach is rarely pursued. Instead, Government actions frequently compound the market failures inherent in the sector and accelerate deforestation. The central need is for Governments to create appropriate policy environments so that forests retain both their essential natural functions and their capacity to support people. In the short run, especially in the tropics, there is an urgent need to stabilize the extent and quality of existing forests by articulating and finding appropriate solutions to the causes of deforestation. In the long term, the

need is to augment forest resources - through reforestation and afforestation as well as sustained, integrated management of existing forests - for improving human welfare, conserving biological resources, and protecting the environment more broadly.

Given the limits of the existing economic paradigm for dealing with the environmental dimensions of forestry, important decisions relating to the use and management of forests must take into account ecological and ethical considerations as well. Incentive policies and market forces by themselves will not guarantee sustainable use and conservation of forests. The participation of the public sector and local communities also is crucial, as is an improved knowledge base for forest management and preservation. There is also a need to ensure the integrity and stability of forest ecosystems by seeking for a balance between development and preservation.

2.5.10 Review of deforestation and degradation: The case of Tanzania

2.5.10.1 Introductory background

Tanzania compared with many other countries is still well-wooded although progressively it is being deforested due to various causes. A large proportion of land is designated as forests. These forests comprise of natural forests and plantations. The extent and distribution of natural forests in Tanzania has been reviewed in section 1.1. However, plantations occupy only about 80 000 ha (Ahlback 1992). Table 2.7 presents forests of Tanzania by use and legal status.

2.5.10.2 Studies and trends of degradation and deforestation in Tanzania

Deforestation in Tanzania have spread rapidly, affecting first of all semi-arid areas where forest and bush regeneration is slow. Cattle raising lands and tobacco growing areas are also especially affected. Based on the assessment of tropical forests and woodlands in 76 countries, including Tanzania, carried out by FAO in cooperation with UNEP within the Global Environmental Monitoring System (GEMS), during 1978 - 1981, deforestation rates were estimated for the period 1976 - 1980 with 1980 as the reference year, and forecasted for the following period 1981 -1985 (Ahlback 1992). For the case of Tanzania, 130 000 ha were estimated to be annually cleared for agriculture, of which 10 000 ha is from closed forest and 120 000 ha from woodlands.

Table 2.7. Forests of Tanzania by use and legal status, figures are in 1000 ha.

Area	Closed forest Mangroves Woodlands Total	1.400'ha 0.117'ha 42.871'ha 44.371'ha
Use	Productive area Unproductive area Total	34.626'ha 9.745'ha 44.371'ha
Legal status	Forest Reserves National Parks Public forest land Total	13.024'ha 2.000'ha 29.347'ha 44.371'ha

source: TFAP (1989).

Concerning closed forest it was assumed that half the cleared area (i.e. 5 000 ha per annum) will not revert to fallow forest because of soil degradation and soil erosion caused by clearing. Concerning woodland it was assumed that a fifth of the cleared area (i.e. 24 000 ha per annum) will be lost as tree vegetation for a long time because of terrain conditions. Four-fifths of the cleared woodland areas were assumed to remain in woodland fallow.

The estimated total annual rate of deforestation in terms of land lost to wood production for a long term thus was 29 000 ha. (i.e. 24 000 ha + 5 000 ha). No deforestation caused by logging or excessive fuelwood collection was noted, only to a certain extent degradation of tree covers. Only clearing for agriculture was assumed to be serious cause of deforestation. The annual deforestation rate of 29 000 ha is in sharp contrast to the rate of 300 000 - 400 000 ha estimated within the then Forest Division some years ago (Kaale 1983, TFAP 1989). It was based on pure "Gap Theory" calculations, treating fuelwood consumption as the sole cause of deforestation, disregarding clearing for agriculture as another major cause (Ahlback 1992). In recent calculations, both clearing for agriculture and collection of fuelwood have been taken into account, with an assumption of population increase year by year. No afforestation efforts are assumed for this calculation, the same rate as the average during 1980s (i.e. 10 000 ha per annum) as reported by Kaale (1983) is assumed to continue. According to these new calculations, the annual deforestation rate during 1990s would increase from about 350 000 ha at present to almost 500 000 ha of which, due to clearing for agriculture from about 140 000 ha to 160 000 ha, due to fuelwood from about 200 000 ha to 330 000 ha (Ahlback 1992).

Other studies to describe and quantify deforestation in Tanzania include those by Norris (1990), Mascarenhas (1991), Bjørndalen (1992), Kaoneka (1993) and Monela, O'Kting'ati & Kiwele (1993). Norris (1990), using Geographic Information System (Analytical Stereo Plotter and GIS ERDAS) analyzed aerial photographs, and maps augmented with field surveys, to quantify deforestation trends in Morogoro Region, Tanzania. The results showed that 0.3 percent per year of rainforest area was converted from rainforest to other more open land use classes. Also 0.5 percent per year of the area outside the reserved rainforest was converted from woody vegetation to cultivated land and wooded grasslands. The rainforest in some places was completely cleared from the lower reaches of the mountain slopes and that substantial areas on the steep upper slopes were cleared of submontane rainforest for new cultivation and settlements.

Mascarenhas (1991), in his overview of deforestation processes in Tanzania, without quantifying it concluded that, the real destruction of forests in Tanzania has taken place because of the changing perspectives of colonial administrators, settlers, national bureaucrats and people who have exploited natural resources during various periods in the name of economic development. Population growth, economic demands, and heavy dependence on natural resources were cited to worsen the situation which is a consequence of the interaction of complex of forces within the social and the biological systems. These forces include clearing for agriculture, overgrazing, charcoal burning, woodfuel harvesting, bush fires, and harvesting for industrial wood. Bjørndalen (1992) gave an overview of why Tanzania's rainforests are vanishing also without quantification. He concluded that human impact around and inside the reserves was considerable with intensive cultivation due to heavy population pressure affecting the reserves from all sides leaving the forests isolated, fragmented "islands" surrounded by the cultural landscape. The role of past industrial logging, foreign development aid, pitsawing and grazing in degrading the rainforests was also noted.

Kaoneka (1993) made a case analysis to illustrate the extent of decline in natural Forest Reserve area as a result of conversion to other land uses. The analysis was based on aerial photographs for Shume-Magamba area in the Usambara mountains covering a period of 20 years from 1957 to 1976. It was found that the natural Forest Reserve declined at a fairly high rate of 3.8 percent per year. The area under farmlands and village settlements increased dramatically by 83 percent per year. It was concluded that the main cause of deforestation is expansion of farmlands and settlements due to growing population.

Monela, O'Kting'ati & Kiwele (1993), using field surveys and interviews assessed and quantified the environmental impact of charcoal consumption along the Dar es Salaam-Morogoro highway, a typical miombo woodland area in Eastern Tanzania. The study results showed that a total of miombo forest cleared annually for producing charcoal was 4354 ha per year or 2.9 percent per year. The study concluded that such a huge area was cleared as a consequence of the fact that energy from charcoal is the most affordable and efficient fuel for most poor urban dwellers in growing urban centres in the study area. The cost to the environment is tremendous.

2.5.10.3 Causes of degradation and deforestation in Tanzania

Population growth

One of the very crucial factors in deforestation is rapid population growth reinforced by various underlying causes such as poverty and unequal access to land. The population of Tanzania is growing at a rate of 2.8 percent per annum (URT 1988). Since independence in 1961, the population of Tanzania has grown nearly threefold, from slightly over 9 million to over 24 million in 1990 (EIU 1994). About 80 percent of the national population of Tanzania lives in the rural areas (NCSSD 1994). The majority of the rural people depends heavily on forests for their survival and most of the export economy is land dependent (*op.cit.*). The basic assumption is that more people will open up more land and this will inevitably lead to all kinds of problems including deforestation (Mascarenhas 1991).

Population distribution and the influence of urbanization

Not only has the population growth been unprecedented, but there also have been significant changes in population concentration and spatial distribution. During the last four decades, the urban population growth has been two to four times higher than the population growth rate. At present, the urban population of 3.5 million makes up for about 18 percent of the national total and grows rapidly at 7 to 8 percent per annum (NCSSD 1994). The impact of urbanization on deforestation is disproportionate to the number of people living in the urban areas. Larger and larger areas around the urban centres have been systematically deforested of their natural vegetation and tree cover. The demand of the urban people is not only for wood based energy but is also for other wood products (Mascarenhas, 1991). Hofstad (1990) notes that, besides subsistence agriculture as one main cause of deforestation in Tanzania, increasing consumption of agricultural crops in urban areas is probably another major driving force behind peri-urban deforestation. Moreover, the rate of substitution between woodfuel (i.e. charcoal/firewood) and other forms of energy (i.e. kerosine, electricity or gas) plays a important role in this dynamic process.

Population distribution and the influence of villagization

Villagization was an attempt to bring rural development in Tanzania through resettlement of peasants in various parts of the country. Though the programme was successful in some areas, it contributed to deforestation by concentrating people in the settlements (villages). As pointed out by Skutsch (1985), the villagization programme had the effect of clearing vast areas around the newly enlarged villages.

Poverty aspect

As poverty has increasingly become an environmental phenomenon, the poor themselves have become a major cause of ecological decline. The principal instruments in this respect are increasingly the rural poor, who have no land at all or insufficient to support themselves. They have no option but to overexploit natural resources in order to survive (FAO 1989). Despite its rich natural resources, Tanzania is one of the poorest countries in the world. The GNP per capita is equivalent to about USD 100 in 1991 (World Bank 1993). Tanzania (mainland) was ranked

as the second poorest country in the world. According to IFAD; in 1988 nearly 12 million rural Tanzanians or 60 percent of the rural population were living below the poverty line.

Most indices of poverty show the rural population to be significantly more disadvantaged than the urban. A recent poverty profile of Tanzania finds rural people to have bigger families than their urban counterparts. Their dependency burden is greater and their income is less. Poverty in Tanzania is overwhelmingly pervasive in rural areas. Over 59 percent of rural inhabitants are in households where, the adjusted household income is below the poverty line. Over 59 percent of the farmers are poor and about 85 percent of all poor people live in rural villages (NEAP 1994).

Policy problems

A Preliminary Report of a World Bank Environment Mission as indicated by Fottland (1993) states some reasons for deforestation in Tanzania, with emphasis on monetary side: (a) Inadequate pricing policy: The price estimated on forest produce when collected from the forest is far below the price that is possible to obtain at the market. This causes a big volume of forest produce to be collected in the field in order to eke out a living. (b) Weak revenue collection: Not just are the initial prices low, as explained above, the collection of the revenue itself is also something left to desire. This causes faulty information on the activity in the forest to be gathered. (c) Lack of capacity to implement policy and legislation: The forest managers have for a considerable time suffered from lack of resources to do good job. Further, the skills and dedication among the staff recruited in this period may deteriorate. Without the implementing capacity, both legislation and policies become quite useless. (d) Insufficient use of market and property incentives: The current land ownership system does not ensure a peasant that if he plant a tree or a woodlot today, he may also be entitled to harvest it tomorrow. Also there is a question on why a local peasant should not collect whatever he can from the forest today, when there may be a logger from far away cutting it tomorrow.

2.5.10.4 Immediate causes of degradation and deforestation in Tanzania

Annexing forest for agriculture and human settlement

Forest land is annexed for agriculture use due to three reasons: (i) When there is population pressure in the area and the current land area under agriculture and settlement is not enough. (ii) When the area under agricultural use becomes unproductive due to poor agricultural practices e.g. when fertilizers or manures are not used, people have to find virgin land, which is temporarily fertile. (iii) The practice of shifting agriculture. Population pressure in Tanzania have resulted into forest encroachment. According to Kalaghe *et al.* (1988), in West Usambaras, population pressure and land infertility precipitated a political decision which resulted in the degazettement of nearly 13 000 ha of the Shume/Magamba Forest Reserve in the 1960s. Encroachment has claimed eight forest reserves belonging to local authorities. In total, an estimated 30 000 ha of natural forests have been annexed for agricultural and human settlement in West Usambaras during the last 30 years. Shifting cultivation is practiced in Tanzania, despite the regulation requiring people to live in permanent villages. In this agricultural system, a forest or woodland is cleared and burned. Agricultural crops are grown for two to three years and after that the farmers shift to another place. The increase in population has diminished the advantages of shifting agriculture. Because of increased population pressure, the fallow period is short, resulting in serious environmental degradation and permanent loss of forestry cover (Nsolomo & Chamshama 1990).

Impact of logging

Forests are source of income through extraction of logs for sawing commercial timber. In most cases harvesting regulations like sticking to the number of trees to be felled as the permit given,

avoiding to fell undersize trees, avoiding to fell trees near streams or rivers and slopes are not followed. Disregard of these regulations have led to deterioration of forests. For example, in the Shume Magamba Forest Reserve, whole mountain slopes have been deprived of up to 70 percent of their canopy trees by logging. In the Nguru mountains the Manyangu sawmill established during colonial times and later closed, had comparable impact (Norris 1990).

Uncontrolled burning and grazing.

Uncontrolled burning is usually carried out in forest and woodland by pastoralist as a way of inducing growth of fresh grass and eradicating tse-tse flies. In addition, farmers also use fire in clearing farms and honey harvesting. The fires are common in dry season and cause great losses in terms of vegetation burned. Grazing destroys forests and woodlands in various ways; by browsing young trees, destroying regeneration, and compacting the soil. The loss of vegetation exposes the topsoil and has resulted into soil erosion in various places such as Kondoa in Dodoma region, Shinyanga and Arusha in Tanzania.

Wood fuel requirements

Woodfuel is by far the main source of energy in Tanzania, supplying 91 percent of the country's total energy demand, while hydropower and oil account for 7 percent and 2 percent respectively (TFAP 1989). Most of woodfuel consumed in Tanzania comes from natural forests and woodlands and over 95 percent of the total population of Tanzania, depend on wood as the only source of domestic energy (*ibid.*). TFAP (1989) record an annual consumption of 40 million m³ and a sustained yield from natural forest and woodland of 19 million m³ of solid woodfuel annually. To meet the consumption, the deficit of about 20.6 million m³ from allowable cut will be met by over exploiting the few existing forests causing deforestation. On the basis of the Gap Theory, this rate was estimated to be 300 000 - 400 000 ha per year (Kaale 1983, TFAP 1989). However, this figure has been disputed of late (Ahlback 1992). The more recent deforestation rate in Tanzania is 130 000 ha per annum (Sharma 1992). It is also important to note that, the deficit cited above is also exaggerated in the sense that, allowable cut is computed from tree boles, ignoring non-bole wood from branches, small plants etc. all of which are used for firewood.

2.5.10.5 Effects of deforestation

Associated with deforestation are some negative effects on the forests and the environment in general. Some of these negative effects which have been observed in Tanzania are as follows:

Gene erosion

The forests of Tanzania are known to be rich in endemic species. The montane rainforests alone, are estimated to contain over 500 endemic plant species (Ruffo *et al.* 1989). The contribution of natural forests in the future as genetic sources of timber trees, medicinal and food plants seems high. Deforestation has probably resulted in extinction of important fauna and flora species, some of them endemic to Tanzania, consequently affecting biodiversity and the economy of the country, since export of plant products such as timber, is one of the sources of foreign exchange.

Water conservation and management

Water conservation and management is one of the most important functions of natural forests in Tanzania. Most of these forests are located in important catchment areas which receive rainfall of more than 1300 mm per annum. Apart from supplying water for household use, natural catchment forests also supply water for economic activities. For example, catchment forests in Kilimanjaro, Usambara, Uluguru and Udzungwa provide water to hydro-electric plants, industrial purposes and agricultural activities. Destruction of natural forests in catchment areas has resulted in negative effects. For example, due to destruction of forests in west Usambara, a total of 400

streams and numerous springs ceased to exist or became seasonal (Kalaghe *et al.* 1988). Water levels in rivers which originates from areas like Uмба and Pangani have decreased. This has affected irrigation activities on the lowlands. Frequent floods and poor water quality are some other side effects. (*ibid.*)

Influence on microclimate

Although in an indirect way, deforestation influences the local climate by retarding water recirculation, lowering air moisture and reducing precipitation. According to Hamilton & Bensted-Smith (1989), the wide range deforestation in East Usambara, has been accompanied by an increase in temperature in the area during the past 10-15 years. Studies on rainfall record from East Usambaras indicate that it has become more erratic (Kaoneka 1993).

Socio-economic aspects

Deforestation has created serious socio-economic problems in Tanzania, mainly by worsening soil degradation accompanied by a reduction in agricultural production. Due to soil erosion, the agricultural area has expanded for the past decade and has simply compensated for the degraded land. Hence production capacity per unit area of both agriculture and livestock land, has declined markedly. This has contributed significantly to the food shortage in the country and as a result necessitated large imports of food items. It is stated that " from being a food exporter in the late nineteenth century, Tanzania has become a net importer (Ministry of Agriculture 1982). It is estimated that about 300 000 tons of cereals have to be imported annually, valued at USD 30-40 million per year (TFAP 1989). Micro-climate caused by deforestation have resulted in losses of both food and cash crops. This have resulted in frequent famines in areas like the Usambaras and thus causing hardship to the people. The loss in revenues due to the failure of cash crops like coffee, affect the local population as well as the Government, since coffee is the major export crop from Tanzania. Deforestation have also created economic burden to the low income group. Purchase of fuelwood in urban areas accounts for up to 30 percent of annual family income, consequently creating heavy economic burden. However, the prices of fuelwood are rising very rapidly due to increasing scarcity, hence exacerbating the problem (Kaale 1983, NCSSD 1994).

2.5.10.6 Efforts in arresting deforestation and forest degradation

Poverty alleviation

Poverty alleviation refers to lifting the poor out of poverty. In attempts to alleviate poverty in Tanzania, the National Policy on Productivity, Income and Prices of 1981 for example, had the following objectives:(a) To reduce income differential among groups, regions and between rural and urban areas. (b) To promote socialist production and distribution. (c) To raise efficiency in resource allocation and utilization, and (d) To speed up national economic growth. A number of economic programmes were eventually launched. The National Economic Survival Plan (NESP) of 1981, was followed by the Structural Adjustment Programme (SAP) of 1982, drawn up for the period up to 1986 when the Economic Recovery Programme (ERP) was started. The main purpose was to revive agricultural output in general, particularly export crops. The measures, were a number of policy reforms including: Increased producer prices, improved supply of agricultural inputs and improved marketing structures by co-operatives. Since 1984, various measures to liberalize trade have also been taken (Tibaijuka 1991).

Soil conservation efforts

Soil and water conservation measures have been practiced for many years in Tanzania. In 1972, the TANU party expressed concern about the havoc which soil erosion was creating and directed that, more effort should be put into soil conservation and erosion control. In 1973, the famous HADO project was established as a national project under the then Forest Division. It started in

Dodoma region one of the most eroded areas of Tanzania. The important components in soil conservation are terracing, planting trees, shrubs and grasses for erosion control. In 1986 HASHI project was started with an objective of environmental conservation in Shinyanga region. Other projects dealing with environmental conservation are, LAMP-Babati, HIMA- Iringa, SECAP-Lushoto etc. The aim of all these projects is to increase productivity and reduce deforestation pressure.

Village afforestation

In Tanzania, village afforestation is one of the major socio-economic development programmes. The programme started in 1967/68 and is part of the rural transformation interventions adopted by the Government after the Arusha declaration of 1967. It is part of the socialist and rural development policies. The objectives have been, to improve woodfuel and building material supply in rural areas, and to reduce pressure on natural forests and woodland as well as maintaining a sound environmental condition for sustained agricultural production (Kaale 1983). The mode of village forestry include: Establishment of pure woodlot and practice agroforestry, and efficient management and utilization of existing natural forest resources, both at village and household level (Ahlback 1988 & 1992).

Conservation and management of natural forests and woodlands

Regarding conservation efforts, over 171 Forest Reserves have been created. Several foreign donors support management of the Forest Reserves, especially targeting the closed forests. The Government have also obtained a loan in the World Bank to manage woodlands and Forest Reserves. Community participation in the management of natural forests is strongly emphasized (CFP 1991, NEAP 1994, NCSSD 1994).

Institutional control of the forests.

In the latest, 1990 restructuring exercise of Government Ministries, the newly created, Ministry of Tourism, Natural Resources and Environment occupies the pivotal position concerning forestry (NEAP 1994). The changes made, put all matters pertaining to natural resources and environment under an overall Ministry. Forestry has benefitted from these changes which have taken place at a time when, there is also great international concern and attention being given to the environment including forestry. Donors assistance to the sector has been substantial (Fottland 1993).

This chapter, has given a review of peasant farming and landuse. It has also presented some key concepts, theories and general background on socio-economic aspects of forest degradation and deforestation in developing countries and in Tanzania. In the following chapters, the discussion will be narrowed down to the specific area (i.e. the Nguru mountains) analytical framework, to provide part of the necessary background for mathematical programming in Monela (1995c).

3.0 THE STUDY METHODOLOGY

3.1 The study area

3.1.1 Origin, location and access of the Nguru mountains

The location of the Nguru mountains has been described in section 1.3 and in Figure 1.1. Access to the Nguru mountains from Morogoro is via the road to Dodoma before branching at Magole village (about 70 km from Morogoro) to take the Mvomero-Turiani-Handeni road which runs in a South-North direction along the eastern slope of the mountains (Figure 3.1). This road is open and navigable in all but the harshest of rainy periods. The road leading to Mhonda Mission (540 m a.s.l.) from Turiani can be used by motor vehicles until the peak of the rainy season when it becomes impassable. From Mhonda mission there is a relatively easy access (1.5 hours walk) to the rainforest and the Forest Reserve boundary (Figure 3.2). The alternative route to reach the rainforest on foot is along the Divue river in the South of Mhonda mission (2.5 hours walk). The Nguru Forest Reserve is not easily accessible from the other lowland areas around the mountains.

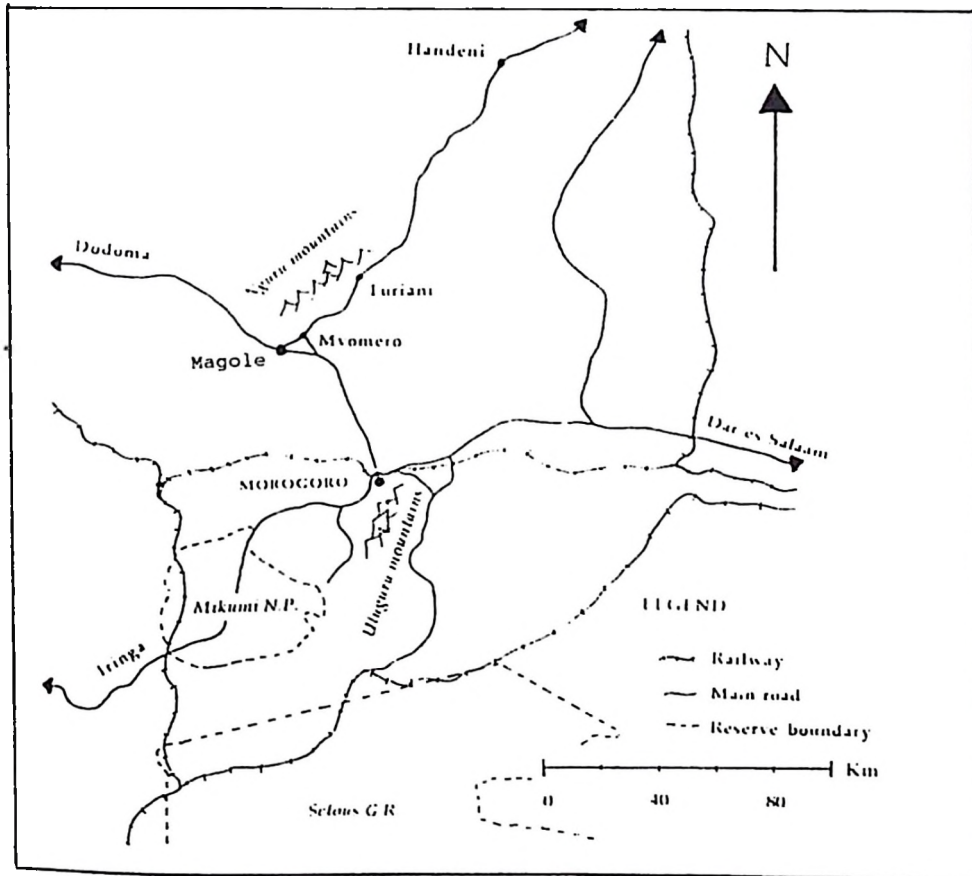

Figure 3.1. Map showing road access to the Nguru mountains.
Source: Skage & Næss (1994).

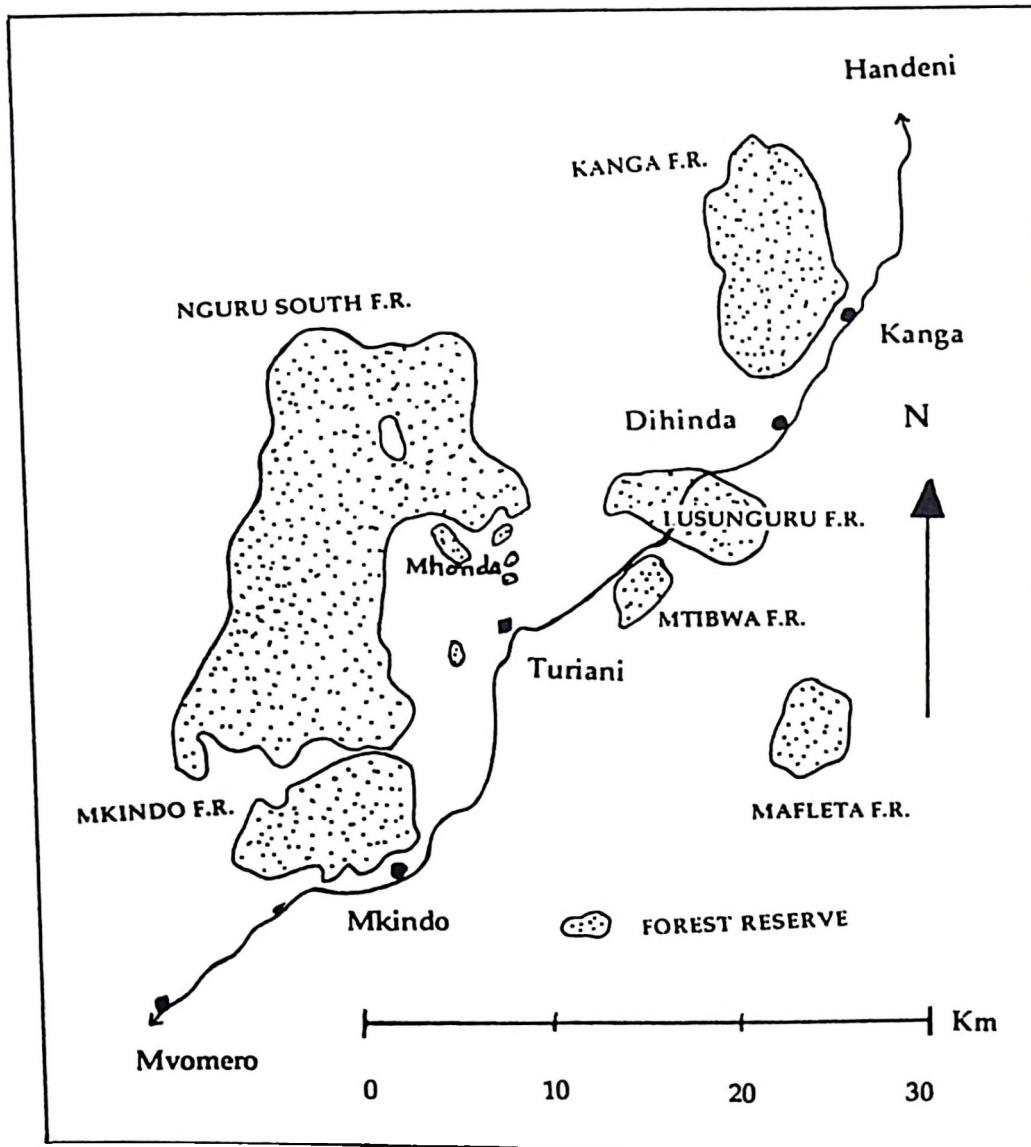

Figure 3.2. Map of the Nguru mountain area showing Nguru South Forest Reserve and Mhonda village. Source: Adapted from Pócs *et al.* (1990).

The "Eastern Arc" mountains extend from the Taita hills in southern Kenya to the Drakensberge in South Africa along the eastern edge of the Central African Plateau (Axelrod & Raven 1978). They were formed out of Precambrian rock during the preliminary break up of Gondwanaland and were uplifted and faulted during the Cretaceous period (*op.cit.*). This is about 65 million years ago (Primack 1993). In Tanzania, the "Eastern Arc" mountains comprise of: the Udzungwa mountains, Uluguru mountains, Usambara mountains, Usagara mountains, Rubeho, Nguu, Malundwe and Mahenge mountains, Ukaguru mountains, Pare mountains and Nguru mountains (Figure 1.1). These ancient crystalline mountains have received moisture from the north-east Trade Winds blowing inland from the Indian Ocean. Over the years these winds had created an environment capable of supporting lush, rich tropical rain forests, which have developed and evolved undisturbed. The forests in these mountains are thought to belong to the Afro-montane archipelago-like regional center of endemism (White 1983). Because of the richness and uniqueness of the flora of these mountains their origin is traced to the possible link between the "Eastern Arc" mountains and Madagascar, before the late Cretaceous dissection of Gondwanaland. The reason being that there is a high floristic correlation between the vegetation in these mountains with that of Madagascar, the Mascarenes and with some parts of tropical Asia than with the younger East African volcanic mountains such as Kilimanjaro, Meru and Rungwe (Pócs 1982).

The high degree of endemism and other phyto-geographic aspects have led to categorization of these East African relict mountain forests as "exceptionally endangered areas" of high conservation value (Myers 1980). According to Coetze (1964), there have been fluctuations in the East African vegetation cover over the years due to climatic changes. However, the rainforests persisted throughout the ages at some level in the mountains. The mountain tops were in effect like islands containing relict patches of moist montane forests and other vegetation types. These were isolated for millennia from other forests, and also partially isolated from each other. The age of these forests, along with the isolation, has led to the evolution of a rich, diverse and distinct flora and fauna, with a large proportion of endemic species in all taxa with the exception of mammals (*ibid.*).

3.2 Data types and collection methods

Primary data were collected by field observation and interviews guided by a questionnaire (Appendix 1). Secondary data were obtained by compilation of information from secondary sources mainly publications, aerial photographs and reports obtained from the local authorities, Government offices and agencies. The local authorities, the Morogoro Catchment Forest Project and District Authorities provided valuable secondary information.

3.2.1 The household survey

This involved administering a questionnaire in Mhonda village, supplemented with informal interviews and discussions with various people in Mhonda and some selected villages inside and on the periphery of the tropical rainforest, during a one year period 1993/94. A total of 77 households systematically sampled were surveyed using a questionnaire. The sample size, the sampling procedure and identification of sample units in the field was based on the procedure explained in Monela (1995c). Informal interviews with people living inside and on the rainforest periphery, and up to three hours walk from the forest boundary were also conducted in a number of selected villages to supplement the questionnaire and to get impression of the overall situation in the study area. These villages are: Mlaguzi, Mhonda, Kambola, Kwelikwiji, Manyangu, Msangazi, Kwadole, Semwali, Lubata, Magunga, Maskati, Ubiri, Kibati Manyangu, Nkombora and Disango. The survey areas were approached on foot using local guides aided by the 1974 Morogoro District Map (Scale 1:250 000). The majority of the interviews were conducted at homesteads and in the field with both men and women participating. The household survey was conducted by the researcher and 5 male assistants, all University graduates with experience in survey work, who administered the questionnaire and conducted the interviews. Living in the

village for the entire survey period, they walked to all areas covered by the survey observing and talking to household members, leaders and people with good knowledge of the community and its environment such as extension staff and other local Government agents therefore, collecting information from well informed sources. The interviewers took time to explain the purpose of the survey, noted the answers in the presence of the interviewees and filled in the questionnaire at the same time. The assessment of the interview process (i.e. quality of the data obtained and interview atmosphere) was also noted by the assistants and evaluated by the researcher. Questions were designed to get information on landuse practices, landuse problems related to agriculture and forestry, and main factors causing landuse problems in the Nguru mountains.

In the questionnaire, by asking questions with regard to non-attractive aspects of forestry and agriculture, landuse conflicts and their main causes were identified. Through questions on local people's dependency on the rainforest and constraints due to collection of nontimber forest products as well as due to cutting of logs, firewood and poles, problems in forestry landuse were identified. Problems in agriculture were identified through questions on constraints to, and impacts of agricultural production. More landuse problems and factors causing them were identified in informal interviews with people with good knowledge about the study area, due to their experience or long stay or service in the study area. These included staff of the Forest Service at local, District and Region level, local leaders and local people. These provided information which has a bearing on landuse and landuse problems. Such information was on local customs and beliefs, use of forest resources, history of the area, as well as the organizational and administrative aspects of land and forest management in relation to landuse.

3.2.2 Field observations

Field observations involved frequent visits (twice per week) in specific forest sites and in the forest as a whole depending on accessibility. The visits aimed at observing and noting the condition of the forest and impact of agriculture and forest exploitation. These field observations involved making transect walks across the forest in several directions such as from bottom of the mountain to the top, and representative transect walks in each specific forest type and following as many established or semi-closed trails as possible. The observations through foot surveys covered the following aspects: prominent bio-physical features, present ecological classification of the vegetation types (i.e. type and location of forest), type and relative abundance of the key and minor species, observable present forest boundaries and ground features with characteristic patterns. Present vegetation and landuse types thus described were classified as belonging to one of the following classes: (i) farmland; (ii) continuous rainforest belt; (iii) patches of rainforest (iv) wooded grassland, scrub and thicket; (v) settlements; (vi) bareland. These classes were also used to estimate landuse/cover changes based on aerial photos and field observation. Besides these classes, ecological description of various vegetation types by elevation was also made.

Depending on the accessibility and type of vegetation in question, estimating the location of forest, present boundary and defining the class was done either by: (i) actually entering the area, and noting the position of the boundary relative to other nearby characteristic features or; (ii) observing the present boundaries from a series of check points giving a good overview of the area in question, and from there, determining its location in the landscape. No ground surveying technique involving equipment other than an altimeter, maps, photos and binoculars were employed. Thus the defining of the boundaries was based on the subjective interpretation and descriptions of the landscape. A series of 35 mm photos were also taken in some selected areas. Notes from the field were compared with vegetation classification map for the area. During these transect walks plants were recorded and specimens taken for identification. The results are reported in Monela (1995b). The identification of the specimens relied on field keys, local expertise and verification at Sokoine University of Agriculture Herbarium and the Morogoro-based National Tree Seed Centre. Foot surveys were undertaken to determine through physical counts, the foot trails and trail density, recent land slides, areas affected by pitsawing and

other cutting down of trees (both licensed and unlicensed), areas encroached for agriculture, areas affected by bush fires and areas affected by extractive use. In pitsawn areas, stumps left after cutting down trees were counted and other impacts determined. Observations were also made on timber harvested and collection of nontimber forest products such as firewood, fodder and food supplements. During these observations pitsawyers and collectors were interviewed. To identify dependency on the Forest Reserve, a dependency indicator used was access to (and condition of) alternative forest outside the Forest Reserve. This was assessed on the basis of maps, interviews and observation. Forest condition was not evaluated independently but considered poor when Forest Reserve at comparable accessibility was definitely preferred. Subjective assessment of relative poverty or ability to purchase substitutes to forest products was also made to give an indication of dependency on the rainforest. This was done by recording, for the sampled households, a number of "village wealth" indicators such as bicycles, stoves, electricity, tap water and Good houses with corrugated iron sheets. Possession of such items indicated ability to purchase substitutes and vice versa.

Pressure was determined by directly assessing effects on habitat, in selected locations especially where timber cutting, pitsawing, firewood and pole cutting were taking place. In order to obtain information about the entire area, assessment of pressure also relied upon forest staff statements and documents indicating geographic distribution of pressure. Depth of the affected area was taken as a measure of the severity of pressure. Although population in the villages and livestock density as well as encroachment incidence, are good approximate measures of pressure, the better indicators used to determine impact on the habitat were (i) proportion of area affected by extractive use; (ii) depth of the affected area; (iii) density of foot trails across the boundary; (iv) density of resident population in the Forest Reserve. The proportion of area affected by extractive use refers to the area where grazing and collecting of nontimber forest products such as fodder, thatching grass, firewood, pitsawn timber, poles, forest food products and medicinal herbs is done by local people residing outside the Forest Reserve. The assumption is that a greater proportion of area affected, reflects a greater overall demand as well as poor resource quality in areas close to settlements. Depth of the affected area (distance from boundary) indicator, complements the affected area indicator. The assumption here is that, grazing and collecting near to the geographic centre of the Forest Reserve, is potentially more demanding than near the periphery. For selected forest blocks/ranges, the maximum distance of affected area was estimated in the field (and with help of a topographic map) at a right angle from the boundary line in steps of 1 km while correcting for ambiguous configuration in some parts of the forest boundary.

Density of foot trails across the boundary was obtained by counting well defined trails which were obviously in regular use by people. To avoid double counting, trails less than 50 m apart were counted as one trail. When the survey line was not identical with the boundary, only trails on the side away from the boundary and leading further into the Forest Reserve were counted. Positions were fixed by landmarks because the survey was conducted on foot. Areas not accessible on foot were not counted. Some blocks could only be accessed through a single route. The assumptions here are that the presence of well trodden trails is an indication of the frequency with which people and livestock enter the grazing and collecting site. Moreover, high trail density and absence of long stretches without trails, indicated widespread use of the area. Density of resident population provided an indication of pressure from within. It involved enumerating villages, people and livestock who reside within the rainforest boundary. Opportunity indicators were assessed by evaluating forest land in terms of offering itself for management in the interest of both people and the forest authorities for specific needs at specific places. Opportunity is the factor which determines what management action can, and should be taken in regard to human dimension hence, is the third important factor next to pressure and dependency.

3.2.3 Data from secondary sources

Publications and reports obtained from the local authorities, Government offices and agencies and personal communication with relevant people at the Morogoro Catchment Forest Project, District

and Regional Authorities provided valuable secondary information on general aspects and on specific issues such as records on offenses in the forest, concessions, arrests, fines, and compounding of offenses, volumes of timber harvested with and without license, landuse problems and their causes, people's attitude on forests and institutional problems affecting land use.

An analysis of land use/cover changes and vegetation classification in the Nguru mountains, was also done based on aerial photos taken in different years supplemented with topographical maps and notes from field observations. This analysis aimed to illustrate landuse and vegetation cover changes as a result of human economic activities and the impact of these changes on the tropical rainforest. Using standard GIS procedure, panchromatic (black and white) aerial photos of 1949 and 1966, on a scale of 1:25000, 1:40000 and 1:80000, obtained from the Surveying and Mapping Division, Dar es Salaam were interpreted and results analyzed. The 1966 photos were of reasonably good quality than the 1949 photos which were of relatively poor quality due to age. No aerial photos have been taken in the area since 1966. Hence documentation of the present (1993) forest coverage essential for estimating recent landuse changes, was therefore conducted solely through field observations carried out during a series of visits to the study site, aided by recent topographical and vegetation maps of the study area (Scale 1:50000, Series Y743 DOS 422, Sheet No. 166/1).

The field observations thus, provided data on present ecological classification of the vegetation types and their location, and type and relative abundance of the key and minor species that were identified. Observable present forest boundaries and vegetation types were compared with those identified on the 1949 and 1966 photos and changes were noted and included on transparent overlays on the 1949 and 1966 photos. Samples of vegetation types, and other ground features with characteristic patterns in the field were sought on the 1949 and 1966 photos, based on characteristic shades and textures which could be easily seen. If found to be still occupying somewhat the same area, and to be of a structure indicative of the structures observed on the photos, these samples were used as keys for identification and classification of other similar vegetation types. By determining the difference in area coverage between the various vegetation and landuse types over time, the land use/cover changes for the period between 1949 and 1994 were determined. The results are presented in Chapter 4.

3.2.4 Data analysis

The data collected using the techniques explained were analyzed by descriptive statistics using frequency counts, tabulations and percentages to elucidate landuses, landuse problems and main factors causing landuse problems in the Nguru mountains. Some data categories and results are reported in Monela (1995b and 1995c).

4.0 RESULTS AND DISCUSSIONS

4.1 Some ecological factors which have shaped landuse practices in the ^Nnguru mountains

Ecological factors have played an important role in shaping the existing landuse practices, landuse problems and factors causing landuse problems in the Nguru mountains. The farming systems, settlement patterns, forestry practices and other landuses existing in the Nguru mountains have been directly or indirectly influenced by the ecology of the area. The ecological factors include geology and soil, topography, climate, vegetation types and fauna ecology. These are described in the sections which follow to elucidate their role in shaping landuse pattern in the area.

4.1.1 Influence of geology and soil

The geology of the Nguru mountains has close linkage to the origin of these mountains described in section 3.1.1. Basically these mountains are built up by fault blocks of old crystalline bedrock. This bedrock of the Nguru mountains and the surrounding area belong to the upper group of the Usagaran System within the Mozambique belt, which is the structural unit in which, a wide variety of sedimentary and volcanic rocks have been subjected to a similar metamorphic history (Axelrod & Raven 1978). A series of geological surveys carried out in the area in the late 1960's and during the 1970's show that, the main constituent of these rocks are gneiss and granulite and to a lesser extent schists and granites (Awadalla 1970). From these rocks the Nguru mountains were uplifted and faulted at the eastern edge of the south-central African Plateau during the Cretaceous times (Axelrod & Raven 1978). There have been no systematic soil surveys conducted in the Nguru mountains in the past. However, the 1976 Atlas of Tanzania soil map based on the United States Department of Agriculture (USDA) Soil Classification System gives some insight of the soils in the area.

The main soil types are entisols and ultisols. These are loamy soils with good drainage. In drier foothills and plains more sandy entisols and vertisols are typical whereas in water-logged plains, inceptisol loams are more predominant. Land tillage and type of implements used have been partly influenced by the geology and nature of the soils. Loamy soils with good drainage require simple tools like a handhoe to till them. So are sandy entisols and vertisols. The water logged soils are also not so heavy for tillage with simple farm implements. The crops grown in the Nguru mountains are also those which can thrive well in such soils. Both shallow and deep-rooted crops are grown. These crops are discussed section 4.2.4 and in Monela (1995c).

4.1.2 Influence of topography

From field observations carried during this study and information from topographical maps of the area, it was found that the topography of the Nguru mountains comprise of the Masumbwe peak, the Central and Manyangu plateaus and the Kanga mountain. Masumbwe peak is 2110 m a.s.l. and forms a landmark. This connects to the Central plateau in the North which covers about 100 km² at 1800 m a.s.l.. The summits of the plateau are not steep and the highest point of the Nguru mountains, Mafulumula peak (2400 m a.s.l.) barely emerges from the surrounding area. However, the escarpments of the plateau are steep and rocky forming high cliffs in all directions. The high precipitation (above 2000 mm per year) received by the plateau has made it dissected by many small streams many of which break into spectacular waterfalls along the edge. The Chazi waterfalls, 250 m high, can serve as an example. The Diwale river separates the Central plateau from the Manyangu plateau with a summit protruding to 1920 m a.s.l.. However, the rocky faces of the plateau extend abruptly to the West and to the North. The Diwale river is an important connection route between the eastern and western sides of the Nguru mountains.

The three blocks (i.e. Masumbwe peak, Central and Manyangu plateaus) which form a chain are separated in the North from the Kanga mountain by the 420 m a.s.l. Mjonga valley. The summit

of the Kanga hills is at 2019 m a.s.l.. In the East-West direction, some dramatic features may also be seen. On the East, the mountains emerge quite abruptly with steep slopes and sharp rocky ridges rising up from the Mkata plains in the alluvial valley of the Wami and Kirengezi rivers. The western and northern slopes are gentle although some cliffs may be seen on the Masumbwe peak and its west faces. This kind of terrain has provided the inhabitants of the Nguru mountains with fertile valleys for cultivation of various crops and streams for irrigation of these crops. The landuse practice and landuse problems in the area have a strong bearing to the terrain factors of the area. For example cultivation along stream banks associated with vegetation clearing is one source of soil erosion which causes loss in fertility and hence decline in crop productivity.

4.1.3 Influence of climate

Climatic data in the Nguru mountains were obtained from several stations located in the area. The lower lying stations at Mtibwa Government plantations and the highest altitude stations, one on the eastern slopes (540 m a.s.l.) at Mhonda Mission and another on the western slopes (1560 m a.s.l.) at Maskati Mission. Records from these stations show the Nguru mountains climate as tropical. Table 4.1 shows a summary of average meteorological data for five stations in the Nguru mountains. Rainfall is high and bimodal with a relatively short dry spell. Heavy rainfall is experienced in March to May and from October to December when the predominantly Easterly Trade Winds bring moisture from the Indian Ocean. March to May is the period of longest and heaviest rainfall. The mean annual rainfall on the eastern slopes (the windward side) varies between 1200 mm and 4000 mm whereas on the western slopes (the leeward side in the rain shadow) it varies between 800 mm and 2100 mm with rainfall being lowest at the foothills and highest between altitudes of 1800 to 2100 m a.s.l.. At higher elevations the precipitation is often higher throughout the year because of contribution from fog and mist. However, as can be expected in such a mountainous area, the rainfall shows much local variation.

Winds are cool to moderate with little drying effect all year round, influenced by the Trade/Monsoon winds. The mean annual temperature varies between 25°C on the eastern foothills and 15°C with occasional frost on the Mafulumula summit (i.e. the highest peak in the Nguru mountains). The annual temperature fluctuations in the area are minimal. However, December is often the hottest month. Due to the relatively high rainfall in the eastern side of the mountains than the western slopes, more crops are grown in the eastern side of the mountains than on the western side. Moreover, farming is a more important economic activity on the eastern slopes than on the western side where, fewer crops can thrive. Thus the nature of landuse practices and problems are considerably a function of the climate of the area. Furthermore, population pressure is higher on the more fertile eastern side with more reliable rainfall. Population pressure have imparted more landuse problems in the area as discussed further in Monela (1995a, 1995b and 1995c).

Table 4.1. Summary of monthly meteorological data in the Nguru mountains, average for five stations.

Item	J	F	M	A	M	J	J	A	S	O	N	D	TOTAL
Mean monthly rainfall (mm) (1952-1981)	133	119	183	236	115	22	17	21	34	68	112	120	1180
Mean monthly Maximum temperature (°C) (1970-1981)	33.7	33.6	33.1	31.5	30.1	29.7	29.5	29.7	30.7	33.3	33.5	34.0	-
Mean monthly Minimum temperature (°C) (1970-1981)	19.0	18.7	18.3	18.7	17.3	14.0	15.6	15.1	15.6	16.6	17.1	17.8	-
Mean monthly evapotranspiration (mm) (1972-1978)	165	175	189	137	107	95	126	114	141	167	170	195	1781
Relative humidity (%)	72.9	73.0	75.2	81.0	80.4	75.2	75.0	73.2	72.5	70.6	69.9	70.4	-

Source: CFP 1994.

Footnote: J = January, F = February, M = March, A = April, M = May, J = June, J = July, A = August, S = September, O = October, N = November, D = December.

4.1.4 Influence of vegetation aspects

The nature and type of vegetation of the Nguru mountains have had considerable impact on landuse practices and landuse problems which exist in the Nguru mountains. Moreover, it is of much interest because of the relatively rich and unique flora still found in the area. The Nguru mountains are among the few areas in East Africa where all the natural vegetation belts can still be found. These range from the miombo woodlands or lowland rain forests on the alluvial plains to the altimontane bamboo thickets on the high summits of the Central plateau. Although these mountains are relatively still unexplored mainly due to inaccessibility of the central parts, field observations in the rainforest showed the presence of rich and unique forest flora as presented in Monela (1995b). These mountains still have large remaining areas of intact rain forest which are rather unique in many characteristics.

Based on the results of field observations, the classification of the vegetation types found on slopes of the mountains revealed the following vegetation types by elevation: (i) Lowland rainforest; (ii) Dry semi-evergreen forest; (iii) Miombo woodland; (iv) Sub-montane rainforest; (v) Evergreen montane rainforest; (vi) Mossy montane rainforest; (vii) Montane rainforest; (viii) Mesic montane evergreen forest; (ix) Elfin forests and ericaceous heaths; (x) Bamboo forests and thickets; (xi) Edaphic communities (Figure 4.1). Most of the Nguru mountains were covered by submontane and montane rainforests usually between 700 and 1800 m a.s.l.. Lowland rainforests were extremely rare because of the extensive agricultural practices in the lowland foothills. Most lowland rainforests have been converted to open farmlands with few trees remaining. This point is further discussed when analyzing landuse/cover changes and-vegetation classification using

aerial photos. Field observations further revealed that farming activities particularly land clearing to open new farms is towards the rainforest. The reasons to explain why agricultural pressure is towards the rainforest are discussed in later sections. Therefore it becomes important to describe the vegetation types in the Nguru mountains in order to appreciate their role in shaping the nature of landuse practices and landuse problems in the area.

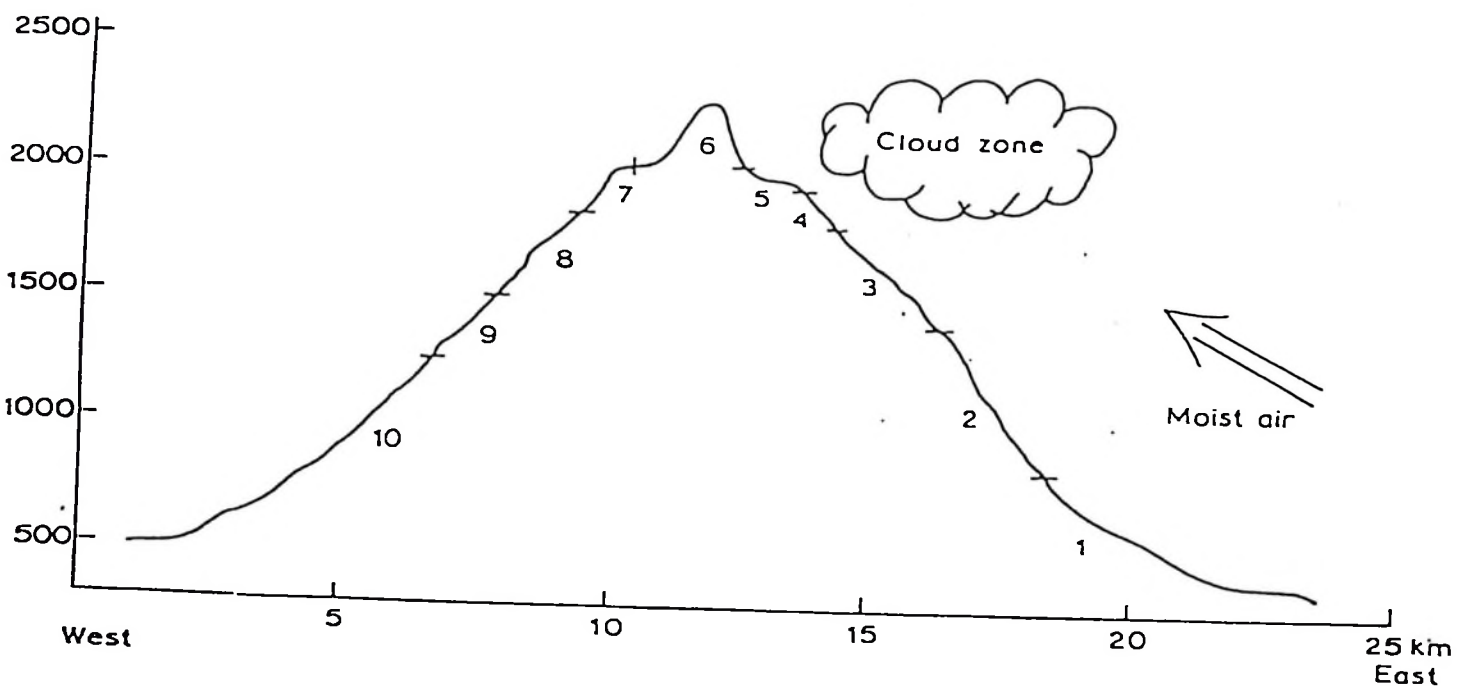

Figure 4.1. Scheme to illustrate the major vegetation types on the Nguru mountains.

Source: Own field data and adapted from Bjørndalen (1992).

- Footnotes:(1) Cultivated land with villages, annual fields and perennial crops, but with remnants of former lowland rainforest occurring as solitary trees or small groves along river valleys
- (2) Submontane rainforest
- (3) Typical montane rainforest, with increasing loads of epiphyte upslope
- (4) Mossy, montane rainforest with extreme heavy loads of epiphytes (cloud forests).
- (5) Mossy, elfin forest with huge mats of epiphytes
- (6) Bamboo thicket/forest
- (7) Rock outcrops with ericaceous heaths (*Erica arborea* and others), Often with endemic giant *Lobelias*
- (8) Mesic montane evergreen forests without a significant content of epiphytes
- (9) Dry/mesic submontane evergreen forests with xerophyllous elements
- (10) Miombo woodland (or other dry woodland/ shrubland).

4.1.4.1 Lowland woody vegetation

This vegetation type was mostly found at an altitude range of between 360 and 800 m a.s.l. and included the following classes: Lowland rain forest, dry semi-evergreen forest and miombo woodlands.

Lowland rainforest

This type of forest is mainly on the eastern slopes where annual precipitation is about 2300 mm. It is characterized by tall forest canopy (30-40 m) but not as variable as that of the submontane forests found at higher altitudes. Patches of this forest type were seen in the lower parts of the Divue and Mkindo valleys. Stands of this vegetation type were also found in the Diwale valley and its side valleys between 550 and 900 m a.s.l. However, most of the area at this altitude is under cultivation pressure which threaten this forest type.

Dry semi-evergreen forest

This climatic climax vegetation was found on the drier lower slopes of the mountains. A moderate tall canopy (8-25 m) was typical feature with partly deciduous species especially emergents. The presence of succulents and tree-sized *Pandanus engleri* was also typical.

Miombo woodlands

These were found up to about 1200 m a.s.l. on the drier northern, southern and western slopes of the mountains and foothills. They are fire climax vegetation type resulting from recurrent regular fires on dry semi-evergreen forests. Several beehives were noticed in this vegetation type particularly in the vegetation close to the forest boundary, in lowland savanna forest and in secondary forests because this vegetation type has more trees which provide flowers for the bees.

4.1.4.2 Submontane rain forests

These forests were found on all parts of the eastern slopes and in wetter valleys on the western slopes between 800 and 1500 m a.s.l.. They were the tallest, most complex forests of the mountains containing most tropical timber trees. The canopy was multi-story, with 40-55 m emergents many of them with buttress roots. The rich tropical rainforest environment with abundant epiphytes, tree ferns, climbers and lianes could be noticed. Rainfall of about 2500-3000 mm of rain per year with no prolonged dry periods is needed to sustain them. These forests together with the lowland forests of the Diwale valley have been most heavily exploited by local sawmills and pitsawyers to the extent that some once abundant species such as *Entandrophragma excelsum* have been wiped out. A drier type of submontane evergreen rainforest was seen on mostly rocky soils on the western slopes below Maskati Mission and on the south-east ridge of Kanga mountain between 900 and 1300 m a.s.l.. This was characterized with a somewhat lower canopy and xero-tolerant species.

4.1.4.3 Evergreen montane rainforests

There were several classes of this forest type varying in structure and composition according to variations in rainfall and altitude. These are (i) Mossy montane forest (ii) Montane rainforest (iii) Mesic montane evergreen forest (iv) Elfin forests and ericaceous heaths

Mossy montane rainforest

This is the most luxuriant type of montane forests found on the upper eastern slopes which receive more than 3000 mm of rain per year and heavily influenced by precipitation from mist and fog. The typical altitude was 1800-2000 m a.s.l. and usually merged into the elfin forests found higher up. The canopy was 20-30 m high and was rich in epiphytes mostly ferns and bryophytes completely covering the trunks, branches and shrubs.

Montane rainforests

These were found between 1400 and 1800 m a.s.l. on the eastern slopes and between 1600 and 2000 m a.s.l. on the western slopes. They generally covered large areas all over the mountains. The multi-story canopy was 20-30 m high and lacked the luxuriant epiphytic cover possibly because it receives less precipitation than the mossy montane rainforest.

Mesic montane evergreen forest

This type of forest had a single story canopy distinguished by its scantiness of epiphytes, lack of tree fern, buttress roots and its much less hygrophillous undergrowth. It was most common on the drier southern and northern parts of the mountains and partly on the western slopes usually between 1500 and 2000 m a.s.l..

Elfin forests and ericaceous heaths

These were altimontane stands of stunted 3-6 m tall trees with a very dense, microphillous canopy. They occurred at or near the upper climatic forest limit or on special soils on the central plateau at the head waters of the Chazi and Divue streams at about 1900-2100 m a.s.l.. On shallow rocky soils, elfin forests were replaced by 2-3 m tall open ericaceous heaths dominated by *Erica arborea* and *Phillipia species*.

4.1.4.4 Bamboo forests and thickets

These bamboo stands occurred above and behind the wettest slopes in the coolest belt of the mountains. The mountain bamboo, *Arundinaria alpina* formed an almost continuous belt on the summit and western slopes of the highest peak of the Nguru mountains, Mafulumula, between 2000 and 2400 m a.s.l.. Isolated stands were also found on the ridges near the southern edge of the plateau and on the isolated summits above Maskati in the west where bamboo stands extend down to 1850 m a.s.l..

4.1.4.5 Edaphic communities

These are plant communities seen in the mountain environment in addition to the forests and woodlands on the slopes, ridges and lowland plains. They occurred as communities adapted to the special situations of bare cliffs and rock, riparian or alluvial plains. Their role in the mountain ecosystem cannot be ignored. Riparian forests are an important and characteristic forest type in the mountain environment. The forests found along rivers and streams on the slopes resembled in structure and composition to their neighbouring forests. However, riparian forests on the alluvial plains to the East of the mountains were quite different. Their emergent trees were deciduous, with only the smaller trees and shrubs being evergreen. In the riparian forests elephant grass were widespread in lowland river courses. Furthermore, much of the permanently flood areas of the Mkata plains along the eastern slopes of the Nguru mountains, now sustain a dense cover of papyrus reeds. Several large mammals evicted from the mountains as a result of human pressure have moved to this area which is extensive enough for game grazing.

4.1.4.6 Cultivated fields, wooded grassland and secondary forest

This class of vegetation in the Nguru mountains is most diverse and heterogeneous because it is in this type of vegetation where human impact is felt most. It is the class representing the greatest uncertainty with regard to definitive vegetation classification. Everything in the open fields was grouped in this class. It included dense, woody secondary vegetation on fields left fallow for a number of years, degenerate or thinned rainforest and groves of anthropogenic exotic trees predominantly mangoes, palms and coconut. Also cultivated fields, wooded grasslands, bushy grasslands, plain grasslands and bare soil also were put in this category. Field observations further revealed that, if land is left fallow after cultivation, the first stage of succession brings in pioneer elephant grass (*Pennisetum purpureum*) which is an indicator of rich soil (Kowal & Kassam 1978). These often form a thick, impermeable jungle of up to 5 m high bamboo-like stalks. Elephant grass were also found on garden boundaries, river/stream banks and valleys particularly in lowland river courses.

In river valleys close to the rainforest where the intensity of cultivation was less, elephant grass was more widespread. On steeper slopes and hills, various ferns created a dense cover about 1.5 m high. In the cultivated fields there was widespread use of fire all the way up to the fringes of the Forest Reserve. The most frequent uses of fire were for clearing land, to stimulate and maintain the growth of the grasses, and to facilitate easy cultivation of crop fields and repelling vermin. Most hill slopes where cultivation had been carried out and fire has been used to clear the land, were devoid of continuous tree canopy but covered by spotted trees and short grass and herbs. Generally, most areas where human activities have been taking place for a long time showed clear evidence of land degradation and in extreme cases deforestation. In many places, slopes showed very clear signs of landslides. In consequence, loose soils from gardens close to the river banks have been washed away particularly in areas with raised stream banks. The presence of *Imperata* grass and poor growth of crop plants especially cassava and banana is an indication that land degradation has taken place in the area.

4.1.4.7 Influence of fauna ecology

The habitat in the Nguru mountains provided by the isolated varied vegetation types and climate give possibility for many fauna species to thrive and find their niche in the area. Several large mammals were seen on the slopes of the Nguru mountains and some hunting has taken place on the eastern slopes. Rich avifauna, some reptile, amphibian and arthropod species were also numerous. Human impact in the area has forced large animals to confine themselves on high mountain slopes with limited altitudinal migrations. Others have migrated downhill to other places mainly to the extensive Mkata plains. The number of large animals is most likely diminishing year after year due to human pressure. Most landuse problems emanating from fauna ecology in the Nguru mountains were found to relate to hunting of wild game for meat. Hunting as a landuse has sometimes been a source of forest fires which destroyed the forest vegetation.

4.2 Socio-economic aspects of landuse in the Nguru mountains

Like the ecological factors, socio-economic factors have also played an important role in shaping the existing landuse practices, landuse problems and factors causing landuse problems in the Nguru mountains. The socio-economic factors discussed here are divided into the following categories: anthropological aspects, human population dynamics, income opportunities, land tenure system and landuse.

4.2.1 Some social anthropology aspects

The land bordering the rainforests in the Nguru mountains is mainly inhabited by the Wanguu tribe who constitute about 95 percent. These people are of Bantu origin. They are mixed with some Wazigua, Wamaasai, Waluguru, Wachagga, Wapare, Wabena, Wakinga and Wahehe who have moved in the area in search of land, grazing ground and employment. The Wanguu are closely related to the Wazigua, a bigger tribe living in Handeni District of Tanga Region. These two ethnic groups speak very close language and have similar social characteristics. The Wanguu like most other Tanzanians speak Kiswahili in addition to their vernacular language. Their social organization is based on local communities although they also have clans. They trace their descent through the male line such that rights to land and livestock are invested in the male line (with father handing property to son). Thus women have little direct influence in matters of wider social concern.

Survey results showed that in matters related to land ownership and control, 77 percent of the land is owned by male household heads and 13 percent by the female spouses. The rest is jointly owned by both. Moreover, 70 percent of the decisions about what crops to grow are done by male household heads. 30 percent of the decisions are made by both. 90 percent of the people who live on mountain slopes are peasant farmers, keeping no or very little livestock (about 1 percent of household economic activities) whereas those who live in the lowland plains particularly West and North of the mountains usually have a number of cattle (about 70 percent of their economic activity). These are mainly Maasai nomads who do not settle in one area for a considerable period. The Wanguu are predominantly moslems (about 70 percent of inhabitants).

However, villages close to Christian Missions such as Mhonda in the eastern slopes and Maskati in the western slopes are predominantly Christian (about 95 percent of inhabitants). The rate of polygamous households is very low constituting about 2 percent of surveyed households, but family size is usually large. The average household has 7 people with 3.9 man-equivalents (based on Due *et al.* 1984, coefficients presented in Monela 1995c). Other demographic characteristics of an average household are also presented in Monela (1995c). Survey results showed that 87 percent of adults were married, 3 percent were unmarried, 3 percent have separated and 7 percent were widowed, or husband has outmigrated. However, out-migration is very low and consequently the number of female headed households is quite low, about 3 percent, whereas the number of male headed households was about 97 percent. Since most areas on the mountain slopes are not easily accessible, people still live in a very traditional style with much beliefs and fear in witchcraft which has hampered social development in the area. Social control is exercised through total social proscription of any culprit.

The political organization of the villages functions well and therefore takes part in reprimanding offenders and guiding the villagers social and economic activities. The Wanguu have strong adherence to their culture and traditional values. While some traditions have been of benefit others have been of very negative impact to socio-economic development. For instance, the belief and fear of witchcraft and lack of interest in education, have had very negative consequences on the standard of living of the local people. However, some local traditional values such as protecting sacred forest groves for worship, have played an important role in protecting some natural forest sites in the Nguru mountains. The local people often link some forests with spiritual powers such that these areas are used for worship, rituals and tribal ceremonies. Some groves are still reserved as cemeteries. Most often these groves are administered by the village elders who also punish violators. Due to such practices, certain forested areas have been left intact.

Apart from forest areas, some individual tree species are also considered to have special spiritual qualities in themselves and hence are treated cautiously. A typical example of such species is *Sterculia appendiculata* and *Ficus capensis* which are thought to be governed by evil spirits and are therefore often left unscathed in the otherwise cleared landscape. A typical example of the forest area left intact is a Forest Reserve of Kanga hill in the northern part of the Nguru mountains. Most of this Forest Reserve is considered to be such a sacred forest and consequently the local inhabitants believe that an outsider who enters the Forest Reserve without undergoing special cleansing rituals is bound to fall victim to the forest ghosts and evil spirits. This has most likely contributed to the unusually limited timber exploitation in the Kanga forests compared to the other neighboring forests (Kalebi pers. comm. 1994). People in the Nguru mountains had positive views on possibility for growing of forest trees in their farm areas and settlements as well. During the survey they expressed a positive view that planting such trees would cool their environment especially during the dry seasons. However, planting of exotic trees is not widely practiced and the main reason given is that people still have the possibility to get forest products from public woodlands and often illegally from the Forest Reserve. No plant nurseries were observed in the villages all the way up to the Forest Reserve boundary. One evidence that people are ambivalent in practicing exotic tree planting can be deduced from people's feelings as expressed during the survey. People expressed the desire to be allowed to clear new farming land

in the forest areas. They also showed resentment on laws restricting to trespass the Forest Reserve for various reasons including reaching mountain villages such as Ubiri and Maskati which are located within the Forest Reserve. Moreover, they expressed the will to be allowed to continue harvesting from the Forest Reserve, dry bamboo, poles and firewood among other forest products for local use.

4.2.2 Human population dynamics

Human population in the Nguru mountains is relatively high. At the time of the survey there were about 18 officially registered villages surrounding the mountains (Mtita pers. comm. 1994). In 1978, about 27,645 people lived in these villages (URT 1978). Also there are sizeable settlements outside these villages particularly in the Ubiri enclave, Kibati, Manyangu, Nkombora and Disango which are like islands of agricultural land within the Nguru South Forest Reserve. In recent years, the Nguru mountains, especially the more fertile eastern slopes have experienced a considerable increase in human population (URT 1988). The population size for Mhonda Ward which lies in the eastern slopes grew from 8,602 people in 1978 to 11,768 people in 1988 (URT 1978 & 1988). This is an increase of 3.7 percent per year which is above the national average of 2.8 percent per year. At District level, the population for Morogoro Rural District which encompasses the Nguru mountains grew at the rate lower than the national average. It grew from 291,110 people in 1967 to 344,081 people in 1978 which is an increase of 1.7 percent per year and also grew to 431,795 in 1988 which is an increase of 2.6 percent per year (URT 1967, 1978 & 1988). Average population density is 30 persons per square kilometre, which is above the average of 26 persons per square km countrywide or 20 for Morogoro region (URT 1988). Morogoro region has a total population of 1,170,706 (URT 1988). Table 4.2 presents the percentage distribution of population by sex and age groups in the Nguru mountains. The fact that females in the most productive working age group (15-64) out-number males can be observed. This has a bearing on the role of women in household economic activities especially farming activities.

Several reasons, discerned during the field survey, may explain this population increase. First, the high "internal growth" rate of the population already established in the area which is 3.7 percent per year for Mhonda Ward and 2.6 percent per year for Morogoro District, where the study area is located (URT 1988). Second, an influx of land-hungry immigrants from other regions particularly the Wachagga, Wapare and Wabena coming from similar environments in the northern and southern regions of the country. Third, the settlement of people previously employed as pitsawyers in the forest (mostly the wahehe and Wakinga from Iringa Region) or as workers at the nearby Mtibwa sugar and teak plantations in the Wami river alluvial plains. Turiani is a small town and the largest human settlement in the area followed by Mhonda village. Both are located in the eastern slopes of the Nguru mountains and are centers of population concentration in the area due to their developed infrastructure and electricity. In Turiani there is a school, a Catholic Church hospital, a police station, shops, a market, restaurants and Divisional and Ward headquarters. At Mhonda village there is a Catholic Church Mission, a Teachers Training College, a dispensary, a school, shops, a carpentry workshop and a market. The rapidly growing population in the Nguru mountains imply that there is also a growing demand for arable land and forest resources which may be one reason for the threat to the tropical rainforest.

Table 4.2. Percentage distribution of population by sex and age groups in the Nguru mountains (N=77).

Group	0-14 years	15-64 years	65 and over
Total	44.8	49.5	5.7
Males	46.7	46.7	6.6
Females	43.1	51.9	5.0

Source: URT (1988)

4.2.3 Income opportunities

The majority of the local people in the Nguru mountains are peasant farmers who absolutely rely on the land and agriculture for their livelihood. About 90 percent of the permanently settled people are peasant farmers in the area where farming accounts for about 80 percent of household earnings resulting from crop sales in the open market. Survey results showed that average household cash income per year is about T.Shs. 100 000 which is below the average annual minimum salary of T.Shs. 120 000. This income is often realized over a long period in a year not at once. Table 4.3 Summarizes the contribution of various income sources to the average household in the Nguru mountains. In this environment of poverty and steady population increase coupled with the degradation of the land already under cultivation, heavy pressure is mounted on the land and forest resources and in consequence forest land is cleared each year for growing crops. The land hunger is so intense that on the heavily populated eastern slopes there is practically no intact forest outside the Forest Reserve. Even the Forest Reserve boundary is under intense pressure due to encroachment.

Besides agriculture, survey results showed that other opportunities for generating income include: casual employment at Mtibwa Sugar factory, Mtibwa Teak plantation and Mhonda Mission carpentry workshop. From Table 4.3, only about 1 percent benefit from this employment. Since only limited casual employment is available, many people rely more on small enterprises like making chewing tobacco, jaggery, local beer brewing, pottery, basket and mat weaving, other local crafts such as making large wooden containers, mortar and pestle, and wooden household utensils. These contribute about 13 percent of household income. Services such as shopkeeping, transport on bicycles, agricultural crop procurement, mineral searching, beekeeping, charcoal burning, local carpentry and so forth are also practiced to a lesser extent. These contribute about 5 percent of household income. Remittances from relatives, credit from neighbours and other income sources account for only about 1 percent of household income. The contribution of forest products (both timber and nontimber) to household income is reported in Monela (1995b). At times farmers get access to institutional credit as a source of working capital. However, this often comes on irregular basis due to institutional impediments. More discussions on institutional credit are presented in Monela (1995c). The surplus from agriculture caters for the daily needs of a household and whenever possible it is reinvested in agriculture or saved as security against future

crop failures. This income is also important to cater for other household expenditures such as industrial consumer goods, obligatory levies etc.

Table 4.3. Contribution of various income sources to household income in the Nguru mountains (N=77).

Economic activity	Percentage contribution to household income	Average annual income (T.Shs./year)
Agriculture	80	80000
Timber and local crafts	13	13000
Petty business	5	5000
Remittances	1	1000
Casual employment	1	1000
TOTAL	100	100000

Source: Own field data

However, due to poor agricultural practices most households get harvests insufficient to yield a big surplus for sale to generate enough cash for the household. Sometimes, households sell a portion of the already insufficient food crops just to generate cash necessary to meet other cash requiring household obligations. As a result, some households have to buy staple food during the last months before the new harvest. This explains why off-farm activities have high potential to supplement agricultural income.

4.2.4 Landuse and tenure rights

Landuse is based on kinship structures which are patrilineal in terms of ownership, inheritance and landuse practices. The functions of land for the people in the Nguru mountains are wider than mere production of crops. Consequently land's role goes beyond crop production. The principal roles of land include: (i) as a dwelling place; (ii) as a source of raw materials: for building, domestic needs and handicraft; (iii) as a grower of crops; (iv) as a provider of grazing ground; (v) as a potential source of money income and; (vi) as the basis of a "social security" system for oneself and one's dependents. The first and last roles (closely related) are the most important ones from a household's point of view. This stresses the non-market aspects of land rights. The major methods for legitimization of land ownership and acquisition of additional land in the Nguru mountains are presented in Table 4.4. It can be pointed out here that inheritance is the main method of land acquisition. Other methods include a village Government allocation and new land clearing in the forest.

Table 4.4. Methods for legitimization of land ownership and acquisition of additional land (N= 77).

Method of land acquisition	Average area (ha)	% of total area	% of households acquiring land by this method
Inheritance	2.08	83.2	92.2
Allocation by village authorities	0.2	8.0	5.2
Clearing of forest land	0.2	8.0	2.6
Purchasing	0.01	0.4	1
Borrowing or renting	0.01	0.4	1.5
Leasing from government	0	0	0
Other	0	0	0
Total	2.5	100.0	

Source. Own field data

Inheritance is the main method of land acquisition. Among the respondents, more than 90 percent legitimize their land ownership based on customary land tenure. Other important methods are village allocation and forest clearing. As human population has grown so have the demands for land, food, fuelwood, building poles and other local forest products. In an effort to fulfill these demands, land degradation and a general decline in land productivity have been the consequences. This has adversely affected the people's standard of living. The patterns of land use in the Nguru mountains are basically the same with some variation between the eastern and western slopes. As earlier, mentioned agriculture is the main landuse competing with forestry and some form of pastoralism, with the latter being confined on the western slopes. In the eastern slopes, very few households keep livestock except for some few sheep and goats in some households. Some land in the area is barren or waste land due to rock outcrops or marshes. There is no land allocated as recreational land, mineral land or commercial land. However, settlements form another important landuse.

Much of the farming system involves annual crops, mixed with some perennial crops. Most villages are surrounded by small fields where crops are grown. On the eastern slopes the crops grown are: maize, beans, cocoyam, sorghum, taro, cassava, sweet potato, banana, sugar cane, tobacco, rice, and a range of vegetables. On the higher altitudinal zones, perennial crops mainly fruit trees, coffee, cardamon and cocoa can thrive well but most cash crops have been neglected and replaced by food crops due to institutional bottlenecks which have restricted economic production of such crops. This issue is further discussed in Monela (1995c). On the higher slopes soils are fairly fertile and rainfall is reliable. Nevertheless, these areas are occupied by the tropical rainforest hence not available for cultivation. Everywhere on the eastern side of the mountains cultivated fields extend up to the forest borders where the soil is more fertile. Some villages like Ubiri are situated within the Forest Reserve and hence scarcity of land is more intense as there is no possibility for expansion except by forest encroachment. The bush fallow/shifting cultivation practiced in the area demands more and more land which in case of

cardamon crop when grown, has to be in the forest because the crop needs moisture, altitude, shade and cold climate to thrive well. On the western side, farming conditions are different. Agriculture is only possible in small valley bottoms near to the mountains and the range of crops is smaller. In this area rainfall is unreliable since the area is on the leeward side thus is situated in the rain-shadow.

Livestock keeping is important in the plains as one moves away from the mountains on the western side. In this area, conflicts for land and water are common between the Wanguu who practice farming and the nomadic Maasai pastoralists who have moved into the area in the recent years. The practice of shifting cultivation collides with the extensive grazing practices of the Maasai. The latter are often on the losing end because they cannot claim any legal ownership of their traditional pastures. The Tanzania Law protects the land rights on cultivated land but not for grazing land (Mascarenhas 1991). Such land conflicts have enhanced the tendency of the pastoral Maasai to move their animals into the forest especially during the dry season hence posing another conflict with the forest environment. Regarding landuse rights in the area, 30 percent of the respondents claimed property rights because they are using the land, 20 percent claimed protection by village government, The rest have claimed to have no rights. Title deed holders were absent.

4.2.5 Agricultural landuse

4.2.5.1 Farming systems

Rain-fed agriculture is the main landuse in the Nguru mountains. Irrigation farming is possible, but is practiced on a very limited scale. Almost all the people who have settled in the area practice some form of farming. Table 4.5 shows the location of farms on the landscape and average land slope in the farms. About 60 percent of the farms are located in upland while the rest are in lowland. Most farms are on sloping ground (> 10 percent) on hill-sides or hill-tops and consequently soil erosion is sometimes a problem. About 54 percent of respondents claimed that farm sizes were inadequate. Consequently with the growing population, the pressure on the limited arable land is quite high. There is great demand for smallholder plots which are used to produce food and perhaps a little extra for sale on the market to earn some cash income.

Table 4.5. Location of farms by altitude and average land slope of land on the farms (N=77).

Position in landscape and slope of land	Percent of farm holdings
Lowland	40
Upland	60
Steep slope	60
Moderate slope	27
Gentle slope	13

Source: Own field data

Several farmholdings are located at long distances up to 5 km but most farms are at an average distance of 1.4 km. The reasons given for farming at long distance include the search for fertile land, lack of land near homesteads or being a traditional way of farming as shown in Table 4.6. Actual average household farm size is in the range of 2-5 ha with an average of 2.5 ha and these holdings are not in single block but distributed in plots averaging 2.5 per household. The main agricultural practice is a basic slash-and-burn technique on same plot. In the cultivated fields, the last season's residues and regrowth is burnt before the land is tilled. In new areas, trees and other vegetation are cleared and burnt prior to tilling. Often, some selected tree species are usually left for specific uses. The soil is hand-tilled with a hoe or pick-axe, followed by manual planting and weeding. Mechanized farming using tractors is practiced on the lowlands where state and parastatal large-scale farms are situated. Previously, the peasant farmers practiced bush fallow/shifting cultivation on the mountain slopes. In this system cultivated fields were left to lie fallow for a period of years after a few harvests so as to replenish soil nutrients and soil structure.

Table 4.6. Motives behind cultivating at long distances from homesteads (N=77)

Motive	Percent of households
Lack of land near homestead	87
Is a traditional way of farming	33
Search for fertile land	33
Risk aversion	0
Other	0

Source: Own field data

Today, the demand for arable land is so high such that fallow periods are either skipped or extremely shortened. Similarly, shifting cultivation is diminishing (Minja 1989, Nsolomo & Chamshama 1990). Over 90 percent of respondents agreed that farm holdings are now used longer (> 5 years) before one can contemplate to abandon them. Table 4.7 shows the responses regarding how long a farmholding has been used continuously. This continuous use of soil without replenishment has resulted in decline in yields. This was a point of view for 70 percent of respondents. Due to the hilly nature of the Nguru mountain slopes, this new practice of continuously tilling the land without proper care has been a source of rapid soil depletion due to soil exhaustion and soil erosion. In consequence, the peasant farmers are compelled to look for new areas especially towards the forest where fertile soils can be found.

One premise that promote this situation is that once agricultural rights of occupancy have been established over a piece of land, felling of trees on such unreserved land is not illegal under the guise of rural development. Soil conservation measures such as terracing, contour planting, strip

cropping or use of fertilizer are rarely practiced even on steep slopes of the Nguru mountains. Flat land tillage is still the main practice and this enhances soil erosion especially when there is no adequate vegetation cover. About 60 percent of respondents acknowledged the presence of a high risk for soil erosion due to lack of soil conservation measures whereas about 50 percent mentioned declining soil fertility as being due to soil erosion. The non-use of soil conservation measures is not due to reluctance in adopting them but the problem is lack of knowledge and a reluctance toward a possible increase in labour demand associated with such practices.

Table 4.7 Responses regarding how long a farmholding has been used continuously (N=77).

Number of years the farmholding has been used	Frequency of households	Percent of households
< 1	0	0
1-2	1	1
2-3	2	3
4-5	5	7
>5	69	90

Source: Own field data

Labour in the household is obtained from household members and therefore the size of the family, sex and age distribution are important factors in the household. Households rarely hire labour due to lack of cash to compensate it. As for limited use of fertilizer the main problem is that most peasant farmers are too poor to afford it even though they realize that they need it. Table 4.8 shows responses regarding various reasons for not using fertilizer. About 73 percent of respondents claimed lack of money as the reason for not using fertilizer. Unless farmers get access to institutional credit, the use of fertilizer may remain low. Nonetheless, most fresh farms are still relatively fertile and can still sustain multiple-harvests for subsistence needs. Thus farmers sometimes take advantage of this nutrient-supplying power of the soil. About 20 percent of the respondents had that feeling (Table 4.8). Despite a high risk of soil erosion particularly on upland farms, natural regeneration of weeds is so rapid that, soil erosion is sometimes less obvious as one would expect. It is important to note that farmers have a wish to use fertilizers to grow big crops in order to make a better living through increased economic return. Unfortunately they lack crucial capital in form of liquid cash which has strong influence on farmer's use of fertilizer. Table 4.9 shows the average present use of fertilizer when extra capital from institutional credit is not available.

Table 4.8. Responses regarding various reasons for not using fertilizer (N=77).

Reason for not using fertilizer	Frequency of responses	Percent of responses
Soil is naturally fertile	15	20
Fertilizer is not available	38	49
Lack of money to buy fertilizer	56	73
Do not need fertilizer	4	5
Do not know	10	13

Source: Own field data

Farmers in the Nguru mountains, also make a limited use of farmyard manure mainly from cowdung. Since domesticated animals are few among farming communities in the Nguru mountains the availability of farmyard manure is limited. If fertilizer is available farmers prefer it than manure because total benefits from manure utilization are sometimes not apparent from crop yields during the first or even second or third year following application. Unfortunately fertilizer is not always readily available, hence manure along with crop residues, is a primary means of replenishing soil organic matter. However, due to manure scarcity the rate applied of 2 tons/acre is below common field rates of 10-15 tons/acre (Brady 1990). A single ton of an average farm manure supplies 5 pounds of N, 1 pound of P_2O_5 and 5 pounds of K_2O and this is equivalent to 100 pounds of 10-5-10 fertilizer (*ibid.*). Thus if manure is applied at common field rates, the total nutrient supplied under practical conditions are substantial and sometimes more than needed for optimum growth. Due to scarcity of both fertilizer and manure application is at times focused on crops of high economic value. In economic terms, the law of diminishing returns is also a factor in fertilizer/manure practice regardless of the crop being grown. Thus the application of moderate amounts of fertilizer/manure becomes urgent for all soils until the maximum paying quantity that may be applied for any given crop is approximately ascertained (Brady 1990). Many households maintain home gardens to raise vegetables for household consumption and for sale. The responsibility of tending homegardens falls on women. However, once the level of production warrants sale on the market, men usually grab control of sales.

Table 4.9. Average present use of fertilizer (N=77)

Type of fertilizer/manure used or non-use	Percent of households using fertilizer or manure	Average quantity used per household (kg/year)
Sulphate of Ammonia (SA)	23	100
Triple superphosphate (TSP)	15	50
Manure	20	2000
Nonuse of fertilizer	62	-
Nonuse of manure	80	-

Source: Own field data

4.2.5.2 Crops and cropping systems

On the windward lying eastern slopes of the Nguru mountains various tropical crops are grown under the three cropping systems practiced in the area. These are monoculture cropping system, mixed cropping system and multiple cropping system. Table 4.10 presents the percentage of households practicing each cropping system and also the average size of the household farm under each cropping system. These cropping systems and the type of crops grown under each cropping system are described in Monela (1995c). However, it is worth mentioning that, rice and sugar cane are also grown as plantation crops in state-owned plantations which are located in alluvial plains of the Wami river. Then there is a vast array of fruits and nuts on the slopes intercropped with subsistence crops. Cash crops such as coffee, cocoa, cardamon, can be grown in the uppermost slopes in the proximity of the rain forest but have been neglected due to institutional impediments.

Table 4.10. Percentage of households practicing each cropping system and the average size of the household farm under each cropping system (N=77)

Type of cropping system	Percent of households practicing the system	Average size of farm per household (ha)
Monoculture cropping system	30	0.9
Mixed cropping system	73	1.2
Multiple cropping system	60	0.4

Source: Own field data

The main cropping system is mixed cropping which one may call a local or traditional agroforestry system. Consequently in addition to a mixture of crops found on a parcel of land, several indigenous multi-purpose trees are retained on the same cultivated land. These are often retained for purposes such as fuelwood, building poles, local crafts and traditional rituals. Table 4.11. shows the types, uses and number of trees retained on the farm. Thus although there is no tradition of agroforestry in the sense of deliberately mixing crops of woody perennials with annual crops, some areas of the cultivated fields still have retained indigenous trees mixed with some multi-purpose fruit trees such as mangoes, orange, citrus, guava, avocado, cashewnut, coconut palm, jack fruit and several others which form some kind of secondary forests, thickets and open woodlands in the landscape.

Table 4.11 Common trees retained on household farms and farm boundaries with their uses (N=77)

Type of tree species	Percentage of households which have retained such trees	Average number of trees per household	Tree uses
<i>Syzygium cumini</i>	13	3	Fw, Fr, Bp
<i>Terminalia catalpa</i>	6	1	Sh, Fr, Bp
<i>Cassia spp</i>	1	4	Fw
<i>Artocarpus spp</i>	1	1	Fr
<i>Mangifera indica</i>	12	1	Fr, Fw
<i>Anona species</i>	10	5	Fw, Fr, Bp
<i>Sena siamea</i>	9	7	Fw, Bp
<i>Anacardium occidentale</i>	7	4	Fr, Fw
<i>Cocos nucifera</i>	17	11	Fr, Fw
<i>Passiflora spp</i>	6	1	Fw
<i>Sterculia appendiculata</i>	1	1	Wo
<i>Ficus capensis</i>	1	2	Wo, Fr
<i>Garcinia spp</i>	1	1	Fw, Md
<i>Alchornea spp</i>	1	4	Fw, Md
<i>Pauridianthus spp</i>	1	1	Fw, Md
<i>Allophylus abyssinica</i>	2	1	Fw
<i>Milicia excelsa</i>	8	6	Ti, Fw
<i>Vitex doniana</i>	3	1	Fw, Fr, Md
<i>Allanblackia stuhlmanii</i>	1	1	Fr, Ti
<i>Psidium guajava</i>	1	1	Fr, Fw
<i>Bombax rhodognaphalon</i>	4	1	Ka
<i>Albizia gummifera</i>	9	1	Fw, Bp
<i>Citrus sinensis</i>	2	8	Fr
<i>Theobroma spp</i>	18	7	Fw, Fr, Md
<i>Carica papaya</i>	6	2	Fr, Md
<i>Persea spp</i>	8	3	Fr, Fw

Source: Own field data

Footnote: Fw = Fuelwood, Fr = Fruit, Bp = Building poles, Sh = Shade, Md = Medicine, Ti = Timber, Wo = Worship, Ka = Kapok

Monocropping is practiced due to various reasons as shown in Table 4.12. The main reasons include: the difference in crop nutrient requirements, to avoid yield loss due to shade and competition and ease of farm operations such as weeding and harvesting. The reasons given for mixed or intercropping are presented in Table 4.13. These include maximization of yield, maximization of labour use, risk aversion, to curb land shortage and as a traditional method of farming. The behaviour to avert risk emanates from several risks in farming as shown in Table 4.14. Overall, respondents indicated that there have been a relatively sharp decline (about 25 percent per year) in crop yields over time. The main reasons cited by respondents being loss of soil fertility due to soil erosion, poor farming methods, limited fertilizer use, drought, poor seed variety and continuous use of soil. About 67 percent of farmers indicated that soil erosion was evident in or around their farm holdings and the main cause is inappropriate farming methods and clearing of vegetation cover.

Table 4.12. Reasons for practicing monoculture cropping system (N=77)

Reason for practicing monoculture cropping system	Percent of households
Difference in crop nutrient requirements	53
To avoid yield loss due to shade and competition	40
Ease of farm operations	30

Source: Own field data

Table 4.13. Reasons for practicing mixed cropping system (N=77).

Reason for practicing mixed cropping system	Percent of households
Maximization of yield	47
Maximization of labour use	67
As a way to avert risk	43
As a way to curb land shortage	70
As a traditional method of farming	33

Source: Own field data

Raising crop producer prices, reducing input prices and giving access to credit were mentioned as important steps to improve land use practices in an environment of many constraints to land use some of which make agriculture a risky venture. Some constraints include erratic climate, lack of inputs, lack of cash, ill health, pests, conflict among land users, institutional impediments, shortage of labour, population growth etc.

Table 4.14. Risks to farming in the Nguru mountains as identified by farmers (N = 77)

Risk condition	Frequency of occurrence	Effect on farming	Risk avoidance technique	Percent of respondents
Floods	Unpredictable	Poor harvest	Staggered planting	40
Drought	Unpredictable	Poor harvest	Resistance crops	50
Storms	Every year	Poor harvest	Mixed cropping	57
Pests/Vermin	Every year	Poor harvest	Staggered planting	40
Price decline	Unpredictable	Low income	Mixed cropping	47
Poor liquidity	Every year	Poor farming	Mixed cropping	80
Lack of markets	Frequently	Low income	Mixed cropping	63
Labour shortage	Every year	Poor farming	Mixed cropping	33
Land shortage	Persistent	Poor harvest	Mixed cropping	60
Fires	Every year	Poor harvest	Clean weeding	90
Famine	Unpredictable	Poor harvest	Mixed cropping	50
Thieves	Unpredictable	Low income	Vigilance	20
Poor rainfall	Unpredictable	Poor harvest	Staggered planting	65
Crop failure	Unpredictable	Poor harvest	Mixed cropping	70
			Food sharing	
			Exchange of goods	

Source: Own field data

4.2.6 Forestry landuses

The types and distribution of vegetation in the Nguru mountains have been described in section 4.1. According to FAO (1984) Forestry as a landuse may be divided into several classes distinguished on the basis of primary purposes and type of forest. The classes are commercial forestry, community forestry, environmental forestry and recreational forestry. Commercial forestry is directed at supplying national or export markets. This may be based on natural forests consisting mainly of the management of the hardwood rain forest formation or commercial forest plantations for timber or pulpwood. Community or social forestry is that directed primarily at the needs of the local community such as fuelwood. Most social forestry has been based on

collection from the natural forest vegetation with little or no deliberate silviculture. Farm and village woodlot established by planting of seedlings form the social equivalent of plantation forestry. Environmental or conservation forestry covers cases where the primary object is either to conserve the natural ecosystem or to restore degraded land. Purposes may include watershed management, soil conservation, soil reclamation, conservation of plant genetic resources and wildlife conservation. Usually several of these objectives are pursued. Recreational forestry, frequently combined with environmental objectives, may include functions with both revenue from tourism and provision of recreation.

In the Nguru mountains, the main class of forest land use is conservation forestry aimed at meeting the needs of the local community within overall national forestry objectives as stipulated in the National Forestry Policy. Social forestry in the area is still based on collection from the natural forest. Some natural trees are often retained on the farm and along the boundary during land clearing and the owner of the farm has the right to use such trees at his own discretion (Table 4.11). Bushes around farms are normally cleared by slash and burn method to keep away vermin. Most households meet their forest product needs from common wood resources in public land or get them legally or illegally from the protected forest. Commercial production has now been prohibited within the Forest Reserve but small scale harvesting is practiced within and outside the Forest Reserve and even this is limited by poor accessibility and low concentration of high value species. Recreation in the forest is curtailed by poverty and poor standard of living of the local populace.

Survey results indicated that many forest products for local consumption are obtained from the tropical rainforest and woodlands in the area as reported in Monela (1995b). Perceived damage to the forests due to local harvesting of forest products was found to be generally low among the villagers. Inappropriate land use practices, deforestation, bushfires and adaptation to poverty were among the main causes of ecological degradation. Important reasons for villagers violating forest protection regulations are ambivalent behaviour, failure of forest authorities to enforce restrictions, need to meet basic needs and lack of perceived threat due to forest destruction. Water needs and harvesting rights were mentioned as incentives for the villagers to contemplate protecting the forest. Ecological stability is superseded by the urge to meet basic needs.

4.2.6.1 The Catchment forest and watershed management

One most important conservation objective of the Nguru mountain rainforests is to protect the watersheds. In Tanzania, watershed management is important due to seasonality and erratic nature of rainfall and the semi-dry conditions prevalent over many parts of the country (NEAP 1994). Watersheds are protected to ensure adequate supply of fresh water to support human life and other life forms as well as for agricultural and industrial purposes. According to Dasgupta (1982), watersheds in the catchment area are often self-sustaining ecological systems where the critical factor is forest cover. The forest cover not only offers direct yield to the rural population, but it also maintains ecological balance and water regime. Furthermore, it prevents floods, droughts, landslides, wind, water erosion and sedimentation. The watershed lowlands and alluvial plains serve typically for staple food production. Once the watershed is threatened by human

disturbance, most of these benefits vanish. Local communities in the Nguru mountains enjoy all such benefits due to the presence of the tropical rainforest in their vicinity.

The submontane and montane rainforests on the Nguru mountains are of vital importance as a water catchment which provide water for densely populated rural areas around the mountains and to distant places. The climate and hydrology of the Nguru mountains are also favourable to this effect. In principle the water movements which influence the catchment start the moment the precipitation from the Easterly Trade Winds hit the forest canopy and continues until the water reaches the major stream leading out of the rainforest. According to Jackson (1975 & 1989) and Bjørndalen (1992) these water movements include: throughfall of rain water, stem flow, interception by vegetation, infiltration into the soil, evapotranspiration loss, surface runoff, percolation in the soil, groundwater movements and seasonality of the process. All these processes influence the amount of water yield and the rate at which it is discharged out of the rainforest. The Wami river is the main outlet for water from the Nguru mountains. Several perennial streams which feed the Wami river originate in the Nguru mountain rainforests and with this water, the Wami river is one of the large rivers in Tanzania feeding the Indian Ocean. The water basins and watersheds formed at various altitudes between 600 and 1000 m a.s.l. in the mountains play an important role to this effect. For example, there is a watershed between Lakigula and Chogwale streams which border the mountains to the west, then turn eastward to form natural borders at the North and South ends of the mountains and finally carrying their waters into the Wami river. The Wami river flows straight East from the south-central part of the mountains, providing water to the dry areas between the mountains and the river delta in Bagamoyo North of Dar es salaam. There are several other streams that flow into the Wami river and these include: Mvaji, Mkindo, Mjonga, Chazi, Diburuma, Sungaji, Diwale, Msengele, Dikurura, and Divue. The Mvaji stream is a source of piped water for domestic use in Turiani and Mhonda villages with cisterns located at 700 m a.s.l..

Economically, the greatest role of the Nguru mountain watersheds is that they provide a steady and reliable flow of water to the rural populace in the area. This uncontaminated clean water is vital to the continued existence of both human and other biological communities both locally and at great distances from the mountain themselves. The Mtibwa Sugar Estate on the Wami river plains East of the Nguru mountains and the Mtibwa Teak Plantations North of the sugar estates also rely on the Nguru mountain watersheds for their supply of water. Furthermore, the Wami river is also the source of water for the nearby large-scale National Dakawa Rice Project as well as large parastatal sisal farms on the plains South of the mountains. The Wami river delta at the Indian Ocean coast near Bagamoyo supports extensive mangrove forests which in their turn are an important breeding ground for many marine organisms such as corals which are vital to the functioning of the coastal environment. The mangroves are also an important source of timber and poles.

The wide recognition of this role of providing a reliable year-round source of water prompted the Tanzania Government several years back to protect this area by starting Forest Reserves. At present, about 61247 ha of catchment forest in the Nguru mountains are under Government control. Out of these about 33005 ha are on the eastern slopes and about 28242 ha are on the

western slopes of Nguru mountains (CFP 1991, Lovett & Pócs 1993). These are recognized as Forest Reserves as presented in Table 4.15 under the Nguru South Range, on eastern slopes in Morogoro District and Nguru North Range, on western slopes in Handeni District.

Table 4.15. Forest Reserves in the Nguru mountains

District	Mountain Range	Forest Reserve	Area (ha)
Morogoro	Nguru South	Nguru South	18800
		Kanga	6664
		Mkindo	7541
Handeni	Nguru North	Kwediboma	285
		Mkongo	985
		North Nguru	14042
		Kilindi	4641
		Derema	3928
		Pumula	1062
		Mbwegere	368
Mkuli	2931		

Source: Mitzlaff (1991), CFP (1994).

All these Forest Reserves fall under the jurisdiction of the Morogoro Region Catchment Forest Project. There are several other Forest Reserves which are administered by the local District Authorities and these cover low hills or are situated on the alluvial plains thus are of less importance as water catchments. Among the important Forest Reserves in the Nguru mountains, Nguru South (including Manyangu forest) is by far the largest and covers about 18,800 ha. Since it covers the highest rainfall area, it has greatest influence on the hydrology of the Nguru mountains. The present study focused on this part of the tropical rainforest in the Nguru mountains.

4.2.6.2 Silviculture in the catchment forest

Following the inception of the NORAD-supported Catchment Forest Project in 1988 to manage some catchment forests in Tanzania, some silvicultural measures have been revived in the Nguru mountain rainforests. With funding from the Catchment Forest Project, field operations such as boundary demarcation, forest restocking, gap-filling, protection, and patrolling are practiced even though still at small scale. Since the catchment forest is not for commercial production, more

emphasis is on silvicultural techniques that enhance forest cover such as encouraging natural regeneration, enrichment planting and proper tending of saplings. The diversity of the forest and lack of basic relevant silvicultural knowledge make this task cumbersome. A similar difficulty has been observed in other catchment forests in Tanzania (Kimariyo 1990).

4.2.6.3 Role of the Morogoro Region Catchment Forest Project (CFP) in sustainable management of the tropical rainforest in the Nguru mountains

History of catchment forests in Tanzania.

In Tanzania the management of catchment forests has been dependent on Government funding. Since disbursed funds are inadequate, mismanagement has been the consequence just like in other forest types in the country. Before 1975 catchment forests were under the control of regional authorities. Between 1975 and 1988 the management of catchment forests was centralized but still depended on Government funding. In 1988 the Norwegian Agency for International Development Cooperation (NORAD) signed an agreement with the Government of Tanzania whereby the Catchment Forestry Project was initiated under the Director of Forestry and Beekeeping in order to take the responsibility of managing some of the catchment forests in Tanzania particularly in the regions of Arusha, Kilimanjaro, Tanga and Morogoro (Fottland 1992). Altogether 110 estates and about 700 000 ha were to be managed as an experiment for sustainable management of catchment forests in Tanzania (*ibid.*). Appendix 3 shows the organization and management responsibilities of the four Regional Catchment Forestry Projects funded by NORAD in Tanzania. The rainforests in the Nguru mountains are included under the Forest Reserves presented in Table 4.15 and these are managed by the Morogoro Region Catchment Forest Project.

The Catchment Forestry Project is divided into two, four-year phases. Phase I, 1988 - 1992 has been completed. Phase II, 1992 - 1996 is in progress. NORAD intervention tremendously improved the funding situation (Fottland 1992). Initial operations of the project were protection, resurveying, boundary demarcation and harvesting. The main initial problems included unclear boundaries, difficulty of identifying gaps for enrichment planting, inadequate staff and poor logistical support. Unclear boundary is cited as the root cause of many other problems (Njana pers. comm. 1994). These are the problems which the project intended to alleviate.

Management objectives and strategy of the Catchment Forest Project.

The general objective of the Catchment Forestry Project is to effectively monitor and utilize catchment forest cover on a sustainable basis. This should be done through strengthening the management ability and through increased community participation in the protection and sustainable use of the Catchment Forest Reserves in line with the Tanzania Forestry Action Plan and Tanzania's priorities. The more specific objectives are: (i) To improve the management of catchment forests in Tanzania by maintaining and utilizing the forest cover in a sustainable manner so that the forest remains diverse and with high forest cover. The outstanding biological

value of the forest in question and the significant potential of increasing the benefits from them are central issues; (ii) To improve the local climate and water flow from the forest; (iii) To stabilize land liable to deterioration and to obtain sustained yield of forest products (both wood and non-wood products); (iv) To protect and conserve various flora and fauna for scientific research. The decreasing amounts of tropical high forest is at present a global concern particularly with regard to biological conservation. Of national value is the basic water and soil conservation properties provided by these forests and the economical significance. The catchment forests are by nature situated at the top end of watersheds and are main contributors of freshwater to Tanzania's rivers. They do in addition largely contain the remaining areas of tropical high forest in Tanzania. To use the Catchment Forest Reserves with nationwide field organization as points of entry to watershed management is thus relevant particularly in establishing a broad basis for sustainable forest management.

The strategy has been to work through the organization already existing for management of Catchment Forest Reserves. However, it is recognized that efficient protection of the forest vegetation and thereby the catchment of water, depends also on areas surrounding the Forest Reserves and how the population living in these areas act. The long-term sustenance of the forest vegetation inside the reserve boundaries is dependent on the well being of these people as well as on the development in the surrounding areas and vice versa. In the first phase of the project the emphasis was on establishment of an administrative structure and traditional forestry activities of basic importance to protection and management of the Catchment Forest Reserves. In the second phase of the project the strategy is to involve the local communities as targeted beneficiaries in management and conservation of biological value of catchment forests. Of decisive importance to achieve the objectives is to address the legal issues and formalities related to forest management with the same force as the activities in the field. However, policing to enforce forestry laws should not destroy the good cooperation that is necessary with the users of the forest produce. The basic idea here is that patrolling activity focusing on traditional policing being practiced up to the present, has to be modified to go along with the concept of people's participation. But strong reactions should be maintained regarding illegal commercial activity causing damage to the forest vegetation. The approach also includes ways of cooperation with other institutions engaged in relevant development work in villages and areas surrounding the Forest Reserves under the Catchment Forestry Project.

CFP implementation

Responsible for the implementation of the CFP is the Forest Development and Management Section under the Forestry and Beekeeping Division of the Ministry of Tourism, Natural Resources and Environment. This section is in charge of forest management in all central government Forest Reserves. The Project implementation is confined to four regions already mentioned above. However, the Central Administrative Office in Dar es salaam takes care of central issues and provide services to the regions. These services include: procurement of items from abroad, operating a special project account, arranging for construction works, issuing consultancies, defining research targets, assembling reports, initiating training, updating of management plans for Forest Reserves and watersheds and updating maps for planning purposes.

The administrative office also keeps track of priorities and progress in the field, as well as changing conditions for funding. Besides supporting normal field operations like boundary demarcation, forest restocking, protection, patrolling etc. in the Catchment Forest Reserves, special Community Participation Pilot Projects have been initiated (Fottland 1992). These are further discussed in later sections.

4.2.6.4 The Nguru South Forest Reserve as a case project for the CFP activities

Management activities under the CFP

The Catchment Forest Project has several management activities:

(a) Resurveying the Forest Reserve to update maps in order to indicate more clearly the forest reserve location and boundaries. (b) Demarcation of Forest Reserve boundaries by planting rows of fast growing exotic tree species. (c) Restocking by planting exotic and indigenous high quality timber tree species in gaps created in encroached areas and pitsawn areas. This is done after farmers have been chased away. The operation involves: planting new seedlings of preferred species, cutting climbers, singling out the naturally regenerating seedlings, clearing around stems by spot weeding or slashing, making firelines and fire prevention in pitsawn area. The species used are mainly *Tectona grandis*, *Khaya antiotheca*, *Grevillea robusta*, *Milicia excelsa*, *Albizia schimperiana*, *Hura crepitans* and *Khaya nyasica*. Among these, *Grevillea robusta*, *Eucalyptus maidenii* and *Khaya nyasica* are most successful in performance. However, *Grevillea robusta* is most often used because it is most preferred by wood consumers and also it does not threaten other species and water conservation objectives of the forest. Planting is by natural regeneration by tending sprouting seedlings of these species. Indigenous tree species are more desirable in order to avoid mixing exotics with indigenous species. (d) Weeding in newly planted areas. (e) Nursery activities (flying nurseries are used to raise seedlings for restocking and enrichment planting to avoid seedling transport cost). (f) Forest protection by policing the boundaries and forest extension service. (g) Preparation of Management Plans in order to improve management of catchment forests. (h) Eliciting or bolstering people's involvement in forest management activities. The main issue is how to involve people who live close to the catchment forests in management activities. It is postulated that since these are the people who cause pressure on the forest, then the only way to reduce this pressure is to improve landuse activities in public lands.

As an example, data for boundary surveying and marking indicate that this activity has been taking place mainly in the Western part of the Forest Reserve. For example, in 1992 the work started in Semwati village at beacon number 120 and proceeded to Kinde village at beacons 121 and 122. By mid-1994, about 73 km of Forest Reserve boundary have been surveyed and 60 km out of the 130 km boundary has been marked by planting trees. The species used in boundary planting are *Eucalyptus maidenii*, *Cedrella odorata*, *Cupressus lusitanica* and *Grevillea robusta*. Last surveying in the Nguru South Forest Reserve was done in 1907 by the Germans. Table 4.16 presents progress of the work for years in which data was available.

Table 4.16. Pace of boundary resurveying and marking in Nguru South Forest Reserve.

Boundary surveying		Boundary marking	
Year	boundary length surveyed (km)	Year	Boundary length marked (km)
1990	59	1990	45
1991	-	1991	15
1992	14	1992	-
1993	-	1993	-

Source: Own field data

Footnote: - means no activity was done due to delay in fund disbursement by the Government Treasury.

Implementing these management tasks requires forest staff and cooperation from villages. Besides the staff at the Regional Office in Morogoro there are 7 Forest Assistants and Forest Guards on regular employment. Among them there are 3 Forestry Certificate holders, and 4 Forest guards with vocational training. Occasionally, local people are employed when there is an operation for a particular activity such as boundary demarcation or bush clearing. School children are also sometimes mobilized especially during tree planting. Staff is provided with working gear in form of motorcycles, bicycles, uniforms, rain coats, machetes and other tools. Staff also get regular training to improve their performance. Evaluation of performance is through reports, word of mouth and surprise checks in the field. Generally, since the inception of the Catchment Forest Project there has been much improvement in performance due to increased and reliable funding and logistical support. Thanks to NORAD for providing support. Besides NORAD support the Morogoro Region Catchment Forest Project raises some revenue from some of the activities taking place in the area. Timber sales were the main source of revenue before government ban on timber harvesting. Revenue is generated from various fines and fees.

According to Kalebi, Njana & Torstad (pers. comm. 1994) and CFP (1994), the main performance problems include: (a) Bureaucracy in discharging decisions and on the part of the Tanzania Government Treasury in releasing NORAD funds which thus reach the project late. (b) Frequently changing policies and directives at Forest Divisional level. (c) At project level, policing the Forest Reserve in accordance with the forest regulation is cumbersome and expensive, so is involvement of local people due to their poor understanding. (d) Inadequacy of Forest Staff. (e) High demand for marketable timber while harvesting in the Forest Reserve has been banned. The new strategy acceptable to the funding Agency, NORAD, is to strengthen involvement of local people in lieu of policing which is expensive and results not good. Zonation of the forest into protected and extractive forests initiated by Mitzlaff (1991) in Handeni District has also been abandoned due to its failure at experimental stage. The main management challenges therefore are to embark on a comprehensive plan for community participation in forest management and to elicit coordination of all donor inputs and government input available for forest management.

Community participation in forest management

Based on the conclusions of the NORAD Review Mission for Phase I of the CFP, the Mission recommended continued support for Phase II after being satisfied with the performance of Phase I. The main emphasis in the recommendation was that Phase II of the CFP be run according to the concept where people's participation is defined as to the direct approach by the project which should strive to attain it. Planning and implementation should embrace people's participation and should be more target group oriented so that women can also be considered as a specific target group, as beneficiaries and actors of forest related activities. At present there are two pilot projects aimed at eliciting community involvement in forest management activities. These two pilot projects are based on two different approaches: (i) Handeni Community Participation Project Approach is for forest staff to live with villagers and work together. This is some kind of Participatory Rural Appraisal (PRA). (ii) Mkindo Community Participation Project. The approach is for the Forest Authorities to communicate with villagers using a "Mediator" approach. In this case the "Mediator" is a Non-Governmental Organization (NGO) hired by the funding Agency, NORAD.

The purpose of community involvement or participation is to reverse the attitude whereby villagers or local communities have always perceived a forester as a "policeman" due to the role he has played in forest protection based on forest law enforcement. This approach has portrayed a forester as an enemy of the local community and as such anything a forester has suggested has been looked upon negatively or with suspicion or skepticism. The forester has also been perceived as corrupt (Fottland 1992). As Westoby (1975) stated: "Foresters should understand that their profession is to serve people, not trees". Also a famous Chinese poem says, as quoted in IDRC Currents No. 6: "Go to the people Live among them Learn from them Love them Start with what they know Build on what they have; But of the best of leaders when their task is accomplished their work is done the people remark We have done it ourselves". The idea of living with the villagers and working with them, or the idea of using a Non-Governmental Organization as a mediator, is therefore meant to evade the negative attitude during the communication process. So the mediator can communicate with villagers in a conducive atmosphere on their needs and their relationship with the Forest Reserve. According to Torstad (pers. comm. 1994) the Tanzania Forestry and Beekeeping Division (FBD) is not in favour of directly using a mediator approach in community involvement. The incumbent Director of Forestry was particularly in disfavour of this approach which he feels enhances tarnishment of the FBD image consequently he prefers the FBD to directly communicate with the villagers. To this effect, one Forest Officer for each village, has been assigned the task of communicating with the local communities in each of the two pilot project villages. These are officers with some skill in better approaches to face the people.

The objectives of the CPP are: (i) To identify problems facing local communities neighbouring Catchment Forest Reserves; (ii) To work out how the local communities can be involved in conserving the existing natural forests for their own benefit and the nation as a whole; (iii) To obtain the balance between environmental and economic interests; (iv) To identify an approach and strategies to involve people in forest management and to increase their awareness

about environmental problems caused by improper land use and how tree planting, soil conservation and sustainable use of natural forests can help to alleviate the situation; (v) To assist village communities on self-help basis in ensuring themselves a sustainable supply of tree and forest products and other benefits from trees; (vi) To reach the villagers themselves directly and deal with environmental issues primarily. Besides the two pilot project villages mentioned earlier, NORAD also initiated in 1987, a two-phase community participation project targeting women as actors and beneficiaries of forest activities. This is known as Morogoro Women Afforestation Project (MWAP) whose activities cover many villages within Morogoro District. Following the completion of MWAP in 1993 the community participation pilot projects (CPP) in the two villages are a continuation of MWAP efforts on environment and forestry matters. The methodology under CPP involves individual visits, meetings and film shows to increase awareness.

According to MWAP (1993) and Chikira (pers. comm. 1994), the accomplishments in villages where CPP is being practiced include: (i) Establishment of village environmental committee to deal with environmental issues at village level; (ii) Women have been allowed to participate in planning and to air their views through holding separate meetings from men; (iii) Each village has established two tree nurseries, one for men and another for women; (iv) Each village has allocated land for demonstration agroforestry plots to mimic villager's own farms; (v) Animal husbandry projects have been started to improve nutrition of villagers; (vi) Forest Reserve adjacent to the village has been zoned to allow villagers regulated harvesting of forest products; (vii) Monitoring of forest activities has been improved; (viii) Villagers are interested in tree planting and see the need to be involved in protection and sustainable use of natural forests; (ix) Villager's now link reduction in farm produce to reduction in forest cover.

MWAP (1993) cites the following limitations to the success of the CPP: (i) Legal problems emanating from organization set up of forestry administration in Tanzania; (ii) Following the Forester's traditional "policemen" role some forest staff are resenting to relinquish the authority they have enjoyed over the years; (iii) Women discrimination (male chauvinism); (iv) Bureaucracy of village leaders; (v) Illiteracy; (vi) Poor farming practices; (vii) Difficulty to meet people during farming season; (viii) Temporary village dwellers not willing to take part in long term investments; (ix) Poor village leadership; (x) Poor village accessibility during rain season; (xi) Food shortage resulting into famine; (xii) Too much dependence on agriculture and; (xiii) Poverty. Among the proposed solutions are (*op.cit.*): (i) To plan forest-related activities such that most are done during dry season; (ii) To avoid whole village meetings, and; (ii) Instead visit households, to initiate programs to increase people's awareness.

Rights of villagers in the Forest Reserve under Community Participation Programme.

Under the Community Participation Programme villager's in the villages earmarked for the programme enjoy some rights regarding the use of the Forest Reserve. In this context a "right" is perceived as a long standing privilege granted to individuals or communities for use of forest resources. There is no charge for such use under a right. Consequently villagers have been led to regard the Forest Reserve as their property and hence they feel that they have the duty to

protect it.

According to Njana (pers. comm. 1994) the villager's rights are: (i) In case there is harvesting in the Forest Reserve the villagers have the right to check the legality and authenticity of the license issued to the licensee; (ii) The village Government has the right to receive part of the proceeds from sale of timber harvested in the part of Forest Reserve under their jurisdiction. Under the existing arrangement, the village has the right to take for village development activities, every 100th unit of timber harvested; (iii) Local forest products rights. Villagers have a non-documented right to collect firewood and other local forest products, access to recreation areas and access to water as a public relations gesture. However, such extraction is supervised or monitored by forestry staff at regular intervals to avoid destruction due to excessive use of the forest. When such products are to be harvested on commercial scale, the permission have to be sought from forest authorities and normal licensing procedure may apply. (iv) Right of way. Villagers have the right to use pathways in the Forest Reserve; (v) Villagers have the right to harvest timber for commercial objectives provided they follow the standard prevailing regulations and licensing procedure.

4.2.7 Pastoralism as a landuse in the Nguru mountains

Pastoralism in the Nguru mountains is only an important activity in the western part of the mountains where the nomadic Maasai pastoralists keep their animals. The Maasai graze their animals in the lowland plains but sometimes move their animals in the Forest Reserve especially during the dry season. They feel that it is their traditional right to graze animals in the forest although they also admit that the increasing use of the forest as a grazing ground is caused by shifting cultivation of the Wanguu farming communities which have tended to drive the Maasai farther into the plains. Furthermore, frequent fires started by the Wanguu in their cultivated fields destroy the Maasai traditional grazing grounds especially during the dry season. Grazing is a serious threat to the forest especially in areas where the forest cover is already degraded by other agents such as pitsawing and fire. These are the areas where frequent animal incursions are very common. North Nguru Forest Reserve which borders the Maasai plains have been a typical victim of such intrusions especially the northern part where thick forest cover has been reduced by logging and fires. The southern part of the Forest Reserve is rarely grazed because forest cover is still thick. Communities in the eastern part of the Nguru mountains which is densely populated and with a reliable rainfall for agriculture, pay little importance to livestock keeping. Very few people in this area keep sheep, goats and chicken around homesteads as part of agro-pastoralism. Agriculture and other off-farm activities are the main occupations in this part of the mountains.

4.3 Landuse problems in the nguru mountains

4.3.1 Nature of landuse problems in the Nguru mountains

The increasing land degradation and deforestation in the Nguru mountains points ominously to the need for the better landuse systems. While land is at intense pressure for cultivation, the

forests are threatened by degradation and deforestation pressure. Hence, landuse problems embrace both the forester and the peasant. For the peasant, the quest for more arable land is the main issue at stake, while to the forester the issue at stake is forest degradation and deforestation pressure. Poor agricultural practices are used in the Nguru mountains causing soil erosion, loss of fertility, decline in harvests and economic repercussions. This has put people's socio-economic development at stake and for peasants in the area, one feasible way out of these problems is to look for ways to expand farmland by invading fresh fields since intensive agriculture is not possible under existing poverty. Retrieving land from the forest is one of the practices due to the sometimes wrong belief that forests harbour fertile soils, also the fact that the forest is the only competing landuse with possibilities for conversion into agriculture. Pressure on the land has become so intense to the extent that old practices such as bush fallow/shifting cultivation have drastically declined.

This practice of continuously cultivating the land in the absence of fertilizer use or soil conservation measures has brought rapid exhaustion of the soil and soil loss due to soil erosion particularly on very steep slopes. The resulting decline in crop harvests is one driving force towards clearing the forest and woodlands in order to maintain crop yield levels. Land clearing towards the remaining woodlands and forests especially on the heavily populated eastern slopes has now left practically no intact forest outside the Forest Reserve. Also the forest boundary is under constant pressure. Those villages which are situated within the Forest Reserve exert pressure from within. Due to land pressure, there is considerable friction between agriculture, forestry and pastoralism to the extent that the Forest Reserve is seen as a constraint to farming activities.

Shifting cultivation, frequent fires and a biased law which protect the farming and forest rights and pay undue regard to grazing rights have led to alienation of the Maasai pastoralist who revert to grazing in the forest during the dry season. The reliance of the local people on the Forest Reserve to meet many of their demands is another source of threat to the forest due to overuse of forest resources. Generally, most of the landuse problems are related to the socio-economic, institutional and political set up; cultural practices, traditional beliefs, physical and climatic factors. Among these problems are: reduction of vegetation cover, soil erosion and deterioration of soil caused by factors such as immoderate and badly planned felling of trees, uncontrolled cutting of firewood, overgrazing, bushfires and shifting cultivation among others. Thus, the analysis of landuse problems in the Nguru mountains need to address the conflicting interests of different land users, their different actions, attitudes and interactions. This is crucial to facilitate integral planning with the objective of preventing land and forest resource depletion and assuring sustainable management. In the sections which follow, some landuse problems in the Nguru mountains are discussed in the context of the threat they pose for agriculture and forestry.

4.3.2 Main landuse problems in the Nguru mountains

4.3.2.1 Encroachment of Forest Reserves for agricultural expansion

With the size of land parcels per capita diminishing over time, intensive agricultural methods to raise agricultural output are essential to sustain food production for the growing population. In the absence of possibilities for intensive agriculture in the Nguru mountains, the need to feed the growing population have led to extensive agriculture practices formerly based on shifting cultivation. Furthermore, the land is now used beyond its capacity due to limited use of fertilizer and soil conservation practices. Substantial areas of forests have been eliminated through farm expansion as a response to increasing demands for food. This expansion of subsistence farming by marginalized peasant households is one main cause of deforestation.

The basic premise for opening up new farms is that, soils in the forest have a high nutrient content with a large proportion of most elements locked up in the vegetation and humus. Once this nutrient capital has been used up after felling and burning of forest vegetation and soil mining, the soils are generally poorer and the tendency for the farmers is to look for fresh areas. The consequence is huge damage to the forest. Table 4.17 presents encroachment for cultivation in the Morogoro District including Nguru South and Mkindo Forest Reserves for the period 1989-1993. It can be gleaned that, a huge area have sometimes been invaded thus shrinking the effective Forest Reserve area or boundary.

Table 4.17. Forest Reserve encroachment for cultivation in Morogoro District for 1989-1993.

Year	Forest Reserve	Area/boundary encroached (ha and/or km)	Remarks
1989	Uluguru North Mkindo Nguru South	54 ha 410 ha 16 km	Farmers evacuated Area being replanted* Cultivation stopped
1990	Uluguru North Uluguru South	5 km 15 ha	Boundary replanted Farming stopped
1991	Mbogo	12 ha	Floods evacuated farmers
1992	nil	nil	nil
1993	Nguru South	12 ha	Culprits jailed 9 months

Source: CFP (1994).

Footnote: * 9 culprits were arrested following there establishment of settlements in encroached areas called Matori and Murango in Mkindo Forest Reserve .

4.3.2.2 Deforestation pressure, forest and land degradation

Like in the other rainforests of the "Eastern Arc" mountains, the impact of deforestation on forests on the slopes of the Nguru mountains has been considerable. Slash-and-burn technique of land clearing and harvesting of the forest to meet local needs are contributing factors to degradation and deforestation. Extensive cultivation has affected the Forest Reserve from all sides in an effort to increase food production. Conversion of forest land to agricultural land is evident at all levels along the eastern slopes, even along the steepest ridges between 900 and 1200 m.a.s.l.. As a high rainfall area with steep slopes, the risk of such deforestation are higher than elsewhere. One consequence of clearing the land up to the Forest Reserve boundary on the steep slopes have been, severe landslides and soil erosion. During the torrential rains of 1968, 1971 and 1988/89 large landslides occurred on the slopes above Turiani village, claiming several lives and destroying several hectares of fertile land and property (Njana pers. comm. 1994).

Also there have been a remarkable decline in the quantity and quality of harvests as a result of soil erosion and nutrient depletion. An average decline of about 25 percent per year in crop harvests was reported by 80 percent of households. The Nguru mountains have not suffered from state initiated large scale-logging programs neither from mineral exploitation in the past as was the situation in the other "Eastern Arc" mountains mainly because of poor accessibility. Nonetheless, other degradation and deforestation agents have taken toll. Even commercial logging by private firms within the rainforest has been discouraged because such logging is famous for bringing down rainforests. Commercial logging is notoriously wasteful because to get at a very few marketable species like mahogany, logging companies often destroy virtually whole forests (Sharma 1992). Large scale lumber exploitation also leads to even more widespread destruction by agriculture since roads cut by logging companies open up forests to farmers (WCED 1987). The consequences of deforestation in the Nguru mountains are mainly apparent through disappearance of forest cover, changes in the hydrological balance of the area and decline of land productivity. Due to the threat to the rainforest, there have been considerable landuse changes and decline in forest cover caused by human impact. Based on aerial photos and field observations, the landuse and vegetation changes in the Nguru mountains were studied to illustrate these changes as a consequence of landuse problems.

Table 4.18 presents changes in vegetation and habitation in the Mhonda area, Nguru South Forest Reserve for the period 1949 to 1993. It can be gleaned from results in Table 4.18 that the tropical rainforest has declined at a fairly fast rate during the period under review. Cultivated fields and settlements seem to have expanded substantially at the expense of forest vegetation. This could be due to population growth in the area. The drastic increase in farmland area is an indication that agricultural expansion to cater for the growing population is one main cause of deforestation in the study area. Meanwhile, there has been no effort to establish forest plantations in the area. Efforts by the Morogoro Region Catchment Forestry Project described in earlier sections to reverse this trend, are a positive step in the right direction.

Table 4.18. Landuse/cover changes in the Mhonda area, Nguru South Forest Reserve

Landuse	Estimated area(ha)			Area change (ha), 1949-1993	Average percent change per year, 1949-1993	Average percent change per year	
	1949	1966	1993			1949-1966	1966-1993
Farmland	3103	3598	3843	+740	0.5	+0.9	+0.3
Continuous rainforest	976	802	723	-253	0.6	-1.1	-0.4
Patches of rainforest	282	188	123	-159	1.3	-2.0	-1.3
Woodlands, Scrub & Thicket	473	226	120	-353	1.7	-3.1	-1.7
Settlements	1	5	n.a.	+4	9.1	+23.5	-
Bare land	-	-	-	-	-	-	-

Source: Own field data

Footnote: n.a.= not available

Table 4.19 presents proportion covered by each landuse class and changes within each class for the period 1949-1993. It is evident agricultural land has been expanding while the rain forest has been decreasing. The increasing proportion of area covered by farmland while forest area is decreasing has a bearing on the role of agriculture in conversion of forest land.

Table 4.19. Proportion covered by each land use class and changes within each class for Mhonda area, Nguru South Forest Reserve, 1949-1993.

Landuse	Estimated area(ha)			Average percentage change per year, (1949-1993)	Average percentage change per year	
	1949	1966	1993		1949-1966	1966-93
Farmland	64	74	79	+0.5	+0.9	+0.3
Continuous rainforest	20	16	15	-0.6	-1.2	-0.2
Patches of rainforest	6	4	3	-1.1	-2.0	-0.9
Woodlands, Scrub & Thicket	10	5	3	-1.6	-2.9	-1.5
Settlements	0.1	0.2	n.a.	-	+5.9	n.a.
Bare land	-	-	-	-	-	-

Source: Own field data

Footnote: n.a.= not available

Based on the "original" landuse/vegetation coverage as found in the 1949 and 1966 aerial photos and field observations in 1993, the percentage area of each landuse converted to (+) or from (-) each landuse class by altitude was computed as percentage of the original size of each landuse as shown in Table 4.20. This table shows the relative changes that have taken place within each landuse class by altitude. For example, they show how much of the rainforest between 500 and

700 m a.s.l. has been converted to other landuses or how much of land has been converted to farmland. It should be noted that some larger classes experiencing low rates of change might actually have larger absolute changes than small classes which have been totally cleared. It can be gleaned from these results that the continuous rainforest has suffered most damage in the altitudinal range of 900-1200 m a.s.l. since 1949. In this altitudinal range a substantial amount of rainforest (about 22 percent) has also been converted to other landuses.

However, since a large portion of the upper reaches of the slopes are covered by rainforest, the changes expressed as percentage of the class/landuse do not reflect the scale of the conversions. In the altitudinal range 500-700 and 700-900 m a.s.l., 3 percent and 9 percent respectively have been converted to other vegetation classes/landuses since 1949. Though these are relatively low percentages of the areas of each altitudinal range, they represent an almost total destruction of the continuous rainforest in these areas due to high intensity of human activities. These forests are most likely "lowland rainforests", a forest type known to have a very limited extent in East Africa and which is rapidly being depleted due to increased human economic activity at this altitude.

The results suggest that conversion from continuous rainforest into cultivated land has taken place at all altitudinal ranges. However, the greatest impact is between 500-1200 m a.s.l. The development of human settlements has also been high over the whole range except at the very top (inside the continuous rainforest), with a somewhat slower growth (33 percent increase) seen between 500 and 700 m a.s.l. and the highest increase (127 percent) up towards the continuous rainforest between 900 and 1200 m a.s.l. This increase is caused by subsistence farmers dependent on cultivation of this land for subsistence. The driving force behind an increased number of huts in the higher altitudinal ranges is the demand for newly cleared forest land which is believed to be more fertile. The drastic increase in human settlements and cultivated land has at lower altitude caused total disappearance of continuous forest at this altitude. The ecological consequences are great.

Table 4.20. Percentage of landuse area by altitude converted to (+) or from (-) each landuse between 1949-1993 in Mhonda area, Nguru South Forest Reserve.

Landuse	Altitudinal ranges (m a.s.l.)				
	340-500	500-700	700-900	900-1200	1200-Top
Farmland	+14	+24	+20	+23	+2
Continuous rainforest	n.f.	-3	-9	-22	-2
Patches of rainforest	-3	-10	-5	-1	n.f.
Woodlands, Scrub & Thicket	-12	-11	-5	-1	n.f.
Settlements	+78	+33	+73	+127	n.f.
Bare land	-	-	-	-	-

Source: Own field data

Footnote: n.f.= not found, which means the land use in question is not found at that altitudinal range.

To get an insight of a comparison between what has happened inside and outside the Forest Reserve during the period 1949-1993, two classes (i) continuous rainforest and; (ii) farmland were selected for comparison and the results are presented in Table 4.21. From this analysis it can be discerned that, there has been little clearing of continuous rainforest within the Forest Reserve itself and the likely disturbances did not amount to conversion of the tropical rainforest into other land uses. Often this part of Forest Reserve have been inaccessible. Moreover, people could get forest products from the periphery of the Forest Reserve without entering the continuous rainforest. Furthermore, forest regulations have concentrated in protecting this part of Forest Reserve. Sometimes local people have respected traditional sanctions against prohibiting the intrusion into densest parts of the rainforest. However, outside the Forest Reserve boundaries dramatic changes have taken place. The continuous rainforest outside the Forest Reserve boundaries has declined by about 1.3 percent per year since 1949. On the lower slopes bordering Mhonda village farmlands, the continuous rain forest boundary has been moved up the slope, straightened out and shortened by 37 percent. "arms" and "fingers" of forest running along ridges or down valleys, and fringing transitional vegetation types have been cleared.

Table 4.21. Changes of area for two selected landuses inside and outside the Nguru South Forest Reserve in Mhonda area (ha).

Landuse	Outside Forest Reserve			Inside Forest Reserve		
	1949	1966	1993	1949	1966	1993
Farmland	2580	3078	3325	525	524	524
Continuous rainforest	437	263	185	539	539	539

Source: Own field data

The analysis of landuse and vegetation cover changes shows that, there has been a substantial increase in the development of settlements and the clearing of land for cultivation. This has been achieved at the expense of the forest cover which has progressively declined during the same period. These changes have taken place at varying rates depending on location and altitude. Low lying slopes have been affected more than higher slopes. The highest rate of deforestation and conversion into agricultural land took place in the range between 900 and 1200 m a.s.l. although substantial clearing in lowland (340-500 m a.s.l.) has resulted into increased cultivated fields by about 20 percent. as shown in Table 4.22 which presents percentage changes in area under each landuse at different altitudinal ranges for the period 1949-1993. The rapid increase in the area covered by settlements between 1949 and 1993 illustrate the rapid population growth that has taken place in the area.

Table 4.22. Percentage changes in area under various landuses at different altitudes for the period 1949-1993 in Mhonda area, the Nguru South Forest Reserve.

Landuse	Altitudinal ranges (m a.s.l.)				
	340-500	500-700	700-900	900-1200	1200-Top
Farmland	+20	+38	+27	+53	+3
Continuous rainforest	n.f.	-100	-76	-39	-3
Patches of rainforest	-83	-131	-134	-81	n.f.
Woodlands, Scrub & Thicket	-77	-62	-92	-91	n.f.
Settlements	+78	+33	+73	+127	n.f.
Bare land	-	-	-	-	-

Source: Own field data

Footnote: n.f.= not found, which means the land use in question is not found at that altitudinal range.

4.3.2.3 Problems due to sawmilling

Although state-initiated commercial logging has not taken place in the Nguru mountains, still some large scale logging by commercial timber companies owned by Sikhs took place briefly until 1960s in Manyangu Valley before it was stopped when the Nguru South Forest Reserve (source of raw material) was put under the control of the Central Government instead of Regional Authorities. The low level of commercial logging in this area as compared to other "Eastern Arc" mountains is partly due to the relatively low concentration of high value indigenous timber species and also due to the poor accessibility of the area (Kalebi pers. comm: 1994).

In the period 1939 to 1969, one Manyangu sawmill practiced intensive logging with heavy harvesting machinery on the North-eastern slopes of the Nguru mountains. The rated production capacity of the sawmill was 3000 m³ per year but the one shift actual production of the sawmill averaged 1500 m³ per year of sawn timber (CFP 1994). Large dimension valuable indigenous timber species exploited included: *Milicia excelsa*, *Entandrophragma excelsa* and *Khaya nyasica* (*op.cit.*). Quite heavy damage was inflicted to the forest and to date, the old logging road from Turiani to Manyangu is still the main access route to the northern and western parts of the mountains (*op.cit.*). Large areas which were cleared as a result of the sawmill have now permanently been converted to residential areas or peasant farm holdings (*op.cit.*). At present, there is no sawmill operating in the area except for the Mhonda Mission carpentry workshop which uses timber from pitsawyers.

4.3.2.4 Problems due to pitsawing

Timber extraction by pitsawing was the main timber harvesting method used in the Nguru mountains. Since the end of 1992, the Government of Tanzania banned timber extraction, including pitsawing in Catchment Forest Reserves after it realized that there was destructive

harvesting taking place. Licensed and unlicensed pitsawyers harvested beyond permissible limits. Another reason for the ban was that harvesting was done haphazardly without proper inventory to monitor available stock and removals. Ideally, pitsawing involves selective felling of trees followed by hand sawing of the logs into boards using a two-man cross-cut saw. One man works the saw from the top of the horizontally lying log and the other man operates the saw from the pit dug under the log (Appendix 4d). The process is arduous, time consuming and requires specialized craftsmen. However, it yields reasonable quality boards which are subsequently carried on foot out of the forest (Appendix 4a, 4b and 4c). Further discussions and references on the productivity and economics of pitsawing are discussed in Monela (1995b). The Wahehe, Wabena and Wakinga from Iringa in Southern Tanzania are commonly recruited for this task whereas the local inhabitants serve only as porters.

Basically, pitsawing is carried out legally or illegally. Legal pitsawing is no longer practiced, and when it was practiced, only few legal licenses were issued in the Forest Reserve. When licensed harvesting was practiced, sometimes felling coupes were designated. A felling coupe is a large area about 150 to 300 ha in size earmarked for selective logging during a specific period of time. Often one coupe is assigned to every 3 pitsawing Contractors (in this context a Contractor is the employer of pitsawyers who may own several crews at any one time). Logging licenses are usually procured by Contractors who then employ the pitsawyers. One potential problem is that these people often exceed the number of trees permitted and the loopholes and flaws originate from poor control by forest staff due to lack of field gear or personnel shortage. Sometimes illegal pitsawing is conducted on night shifts where small trees that can be rapidly sawn and taken out of the forest easily are the main target. Each felling coupe boundaries are defined by physical features such as rivers, valleys, rock outcrops or steep slopes. In a coupe, trees to be felled are usually counted, marked, numbered and diameter at breast height (dbh) or girth is measured using diameter tape.

Before the 1992 Government ban of timber harvesting in catchment forests, there were a total of 8 operating felling coupes for both Mkindo and Nguru South Forest Reserves. Some of these felling coupe areas, though closed, were visited during field visits to monitor the impact of pitsawing in these areas. Those visited were: Mlaguzi (I), Mkindo (II), Divue (III), Diongoya (IV), Ubiri (V) and Kwelikwiji (VI). In the first half of 1990, there were only 6 legal licenses operating in Nguru South Forest Reserve with an average of 7 trees each, spread on 5 different sites on the eastern slopes. Following the ban by the Government of Tanzania on licensed timber harvesting in all Catchment Forest Reserves since the end of 1992, illegal felling of trees has continued. One possible explanation for the flourishing of illegal pitsawing is that, the difficult terrain and the fact that most easily accessible high value timber have been exploited, renders this enterprise less profitable if it is pursued along legal lines. Before the ban, licenses were issued following the standard licensing procedure which is described in Monela (1995b).

Table 4.23 presents licensed harvesting which took place in the Nguru South and Mkindo Forest Reserves for the period 1989 - 1992. It can be gleaned that, the quantity of timber harvested was substantial amounting to an average of 572 m³ per year for Nguru South Forest Reserve and 104 m³ per year for Mkindo Forest Reserve. Since there is also illegal pitsawing, timber removals

from the forest are substantial, causing negative impact on the ecology of the rainforest. Table 4.24 presents for the period 1989-1994 arrested and observed but unarrested illegal harvesting activities in the two Forest Reserves. From the amount of recorded and observed illegal pitsawing, it is clear that a substantial amount of illegal harvesting has been taking place in the area even after the Government ban in 1992. However, the frequent escaping of culprits in the reported cases may serve to indicate some weakness on the part of local forest staff in the area to arrest the culprits. The species in highest demand by pitsawyers are those which produce high value marketable timber. They include *Milicia excelsa*, *Newtonia buchananii*, *Caephalosphaera usambarensis*, *Ocotea usambarensis*, *Entandrophragma excelsa*, *Khaya nyasica*, *Podocarpus milanjanus*, and *Pterocarpus angolensis*. Some of these species can sometimes be obtained from woodlands outside the Catchment Forest Reserves. In such public areas trees can be cleared once rights of occupancy have been established. Licenses are only required if one is to fell reserved species or if the felled tree is to be sold and utilized commercially. For the list of Reserved Tree Species in Tanzania see Appendix 9 in Monela (1995b).

Table 4.23. Licensed harvesting in Nguru South and Mkindo Forest Reserves during the period 1989-1992.

Forest Reserve	Year	Number of licenses issued	Number of trees harvested	Volume of timber harvested (m ³)
Nguru South	1989	36	218	1051
	1990	8	46	261
	1991	16	98	385
	1992	22	139	591
	TOTAL	82	501	2288
Mkindo	1989	6	30	95
	1990	10	55	212
	1991	6	23	92
	1992	2	7	19
	TOTAL	24	115	418

Source: CFP (1994).

Table 4.24. Illegal harvesting in Nguru South and Mkindo Forest Reserves during the period 1989-1994.

Forest Reserve	Year	Number of arrests/cases	Number of timber pieces apprehended	Action taken against culprits	Observed but unarrested illegal pitsawing activities
Nguru South	1989	nil	nil	nil	2
	1990	2	16	jailed 6 months	3
	1991	1	100	culprit escaped	2
	1992	2	115	culprit escaped	3
	1993	2	65	culprit escaped	6
	1994	nil	nil	nil	11
	TOTAL	7	296		27
Mkindo	1989	nil	nil	nil	3
	1990	1	16	jailed 9 months	4
	1991	nil	nil	nil	2
	1992	nil	nil	nil	3
	1993	2	25	culprit escaped	5
	1994	2	180	culprit escaped	7
	TOTAL	5	221		24

Source: CFP (1994).

Footnote: nil means, no arrests were made.

Table 4.25 presents a list of pitsawn trees by species and girth range (at dbh) in various felling coupes in the Nguru South Forest Reserve. This can serve to indicate pitsawyer's and consumer's preferences. It can be noted that some of the preferred species do not appear in the Table 4.25. This may suggest that, such species are no longer within easy reach as a result of "creaming" such that the preferred tree species and sizes may have disappeared. Another reason could be excessive exploitation which may have been practiced in the past, both legally and illegally. According to CFP (1994), the main critique of pitsawing in the area is that, its selective felling tends to deplete the gene pool of the selected species. Also the practice is wasteful since only a limited log is used. Sometimes entire trees that fall in difficult direction are abandoned. Furthermore, it destroys the forest canopy structure by gap creation and sometimes people have established permanent settlements in these gaps which is more detrimental to the forest. Nonetheless, pitsawing if properly controlled (supervised) has advantages in catchment forestry compared to mechanical logging because it is less destructive than the latter. Also the limited extraction from the forest under pitsawing conserves more nutrients within the ecosystem than if whole trees were removed. Moreover, pitsawing does not cause deforestation in the strict sense of the term, but may result in forest degradation if not properly supervised. The reason is that pitsawn trees are often scattered at long distances such that pitsawing is selective felling.

In the Nguru South Forest Reserve for instance, a felling coupe can have an area of 100-150 ha in which, only about 250 trees can be marked as being suitable for pitsawing. In such case, pitsawing cannot be compared with clearing the forest for farming or harvesting by clearfelling.

During the field survey, some important features of pitsawing in the Nguru mountains that cause damage to the forest and their impact were observed. These were as follows: (a) When harvesting was not properly supervised, trees were felled close to the river and stream banks. Coupled with pits dug to facilitate pitsawing, this have affected stream flow because of soil sediments, tree branches and other debris (parts of trees) that fall into the stream/river bed. Another consequence is reduced water flow or drying up of seasonal streams due to loss of vegetation on stream banks or opening up of vegetation cover at stream sources and siltation. Pits dug during pitsawing are of the following average dimensions: Length = 2 m, Width = 1 m, Depth = 1.5 m. Hence, making such pits causes substantial damage to the vegetation cover. (b) When trees fall, they usually fall on other vegetation and trees underneath hence damaging them through breakage. Most of this damage was attributed to lack of expertise in tree felling techniques among most pitsawyers. (c) Pitsawyers are only interested in the main stem of the tree which they use and leave the rest of the tree to rot. (d) Pitsawyers make foot trails in the forest some of which later develop into gullies or create access to the forest by other people involved in other activities which cause damage to the forest. Examples are firewood collectors, animal and honey hunters etc. (e) On very steep slopes, pitsawyers transport timber by sliding it down slope, thus damaging vegetation and creating gullies after heavy rainfall. (f) There are a number of activities associated with pitsawing that cause damage to trees and the other vegetation.

Table 4.25. List of pitsawn trees by species and girth range (at breast height) in various felling coupes in the Nguru South Forest Reserve for the period 1989-1994.

Felling coupe location	Tree species (Local/Trade name in bracket)	Number of trees	Girth range at breast height (feet) ⁽¹⁾
Mlaguzi	<i>Newtonia buchananii</i> (Mnyasa)	7	9-15
	<i>Entandrophragma stolzii</i> (Mbokoboko)	13	10-17
Divue	<i>Entandrophragma stolzii</i> (Mbokoboko)	12	8-13
	<i>Newtonia buchananii</i> (Mnyasa)	5	8-12
Diongoya	<i>Pterocarpus angolensis</i> (Muninga)	7	6-7
	<i>Milicia excelsa</i> (Mvule)	18	9-13
Ubiri	<i>Newtonia buchananii</i> (Mnyasa)	20	8-13
	<i>Entandrophragma stolzii</i> (Mbokoboko)	3	9-14
Kwelikwiji	<i>Newtonia buchananii</i> (Mnyasa)	9	9-12
	<i>Entandrophragma stolzii</i> (Mbokoboko)	6	10-14
	<i>Milicia excelsa</i> (Mvule)	1	10
Mkindo	<i>Ocotea usambarensis</i> (Mkulo)	31	2.7-3.6
	<i>Carapa grandiflora</i> (Muhumbulia)	6	3-3.6

Source: CFP (1994)

Footnote:(1) 1 Foot = 30.48 cm

These include: (i) Fire for cooking when left unattended have sometimes spread in the forest causing heavy damage especially in the dry parts of the forest. Such fires fail to spread in the continuous rainforest where most of the vegetation is usually green; (ii) Collecting firewood for cooking by the pitsawyers have often involved cutting down some trees to dry up as firewood source; (iii) Construction of shelter for pitsawyers requires wood and also involves clearing vegetation on the shelter site and the beddings are also made from wood. Such shelter is for sleeping at night, resting place during the day and is for protection against rain, sun, wild animals etc.; (iv) Since shelter is normally constructed in proximity to streams/rivers, water pollution becomes an inevitable consequence due to littering, and open latrines for human excrement. In extreme cases excretion is done in the open and rain water washes everything downstream.

Littering emanates from food remnants, trash from cooking, food containers etc. (v) Poaching wild game for meat and trophies. Pitsawing contractors (i.e. employers of pitsawyers) disguise by going into the forest to supervise pitsawing activities while their true aim is poaching. Despite these damaging effects of pitsawing, vegetation recovery in pitsawn areas was observed to be fast to the extent that 2 years after logging has taken place, the vegetation cover is almost complete in logged areas (Kalebi pers. comm. 1994). This is attributed to the rainforest environment where there is sufficient moisture and organic matter. This is also attributed to absence of soil compaction as no vehicle movement takes place in such areas. Only human feet use such area. In pitsawn areas, the fast naturally regenerating trees especially by coppicing or root suckers are: *Milicia excelsa* and *Ocotea usambarensis*. These are often joined by herbs of various species. Sometimes pitsawyers are coerced to replant trees in areas where they complete logging. This is done even in logging roads not to be used again in the near future. According to CFP (1994), survival rate of such replanted trees is almost 100% due to high soil fertility and sufficient moisture in the rainforest.

During gap filling activities conducted under the Morogoro Region Catchment Forest Project, trees are also planted in areas pitsawn in the past. Among the activities performed in pitsawn areas are: planting new seedlings of preferred species, cutting climbers, singling out naturally regenerating seedlings (i.e. reducing the number of seedlings regenerating on one stump), spot weeding (i.e. weeding around a growing seedling), slashing and making firelines (*op.cit.*). Observation was also made on what happened to pitsawing pits several years after pitsawing was done. It was observed that after pitsawing, the pitsawyers left the pits open without filling them back. In consequence, they created a danger to humans as well as animals who might fall into such open pits and break their limbs. The common practice is to leave such open pits to naturally fill up completely. This process takes about 5 or more years. However, vegetation often invades these pits even before they are completely filled up and in consequence reduces their impact (Kalebi pers. comm. 1994).

For comparison purpose, the visible effects of past mechanical logging in the area were also observed. The following were some of the negative consequences of mechanical logging still noticeable in the Manyangu valley where mechanical logging was practiced during the period 1939 to 1969: (i) Construction of roads to logging sites resulted into vegetation clearance. (ii) In steep slopes such roads have caused soil erosion gullies and land slides; (iii) Compaction of the soil have impeded natural regeneration of vegetation.

4.3.2.5 Problems due to dependency of local communities on the tropical rainforest

Dependency of the local communities on the Forest Reserve is a good indicator of the level of forest degradation caused by forest product collection for local consumption. Survey results showed that for about 25 percent of the villagers, the forest outside the Forest Reserve was nearer and more easily accessible. But even these still used the Forest Reserve as a source of some forest products. This is explained by the poor quality of the forests outside the Forest Reserve and weak law enforcement by the Forest Authorities. Actually, village commons land (defined here as village owned land or privately owned land if left unused), regardless of quality, is small, due to intensive cultivation. Wasteland to be reclaimed is also rare. All of the forest patches outside the Forest Reserve, are *de facto* village commons property and little firewood remains below the canopy of such trees. For 75 percent of the people interviewed, the Forest Reserve was a more reliable source of firewood, water, poles and other forest products.

Dependency for water and other products in the Forest Reserve is highest during the dry season. For example, besides streams and rivers, some permanent water holes, very useful during dry season, are located inside the Forest Reserve. Nevertheless, the Forest Reserve was not a preferred source for about 90 percent of respondents due to possibility of being apprehended by the Forest Authorities. The proportion of the forest reserve area affected by collecting activities was estimated to be about 41 percent of the total Forest Reserve area and this gives some impression of the extent of the pressure on the Forest Reserve. Timber, firewood, building poles, hunting honey and wild game, wild food, and grazing were the main reasons for deep penetration into the Forest Reserve. The maximum depth of the affected area ranged from 0-5 km from the Forest Reserve boundary. In few places people go deeper inside the Forest Reserve. Moreover, there is a substantial population size in villages resident inside the Forest Reserve (i.e. villages within the Forest Reserve and squatters). For example, one village at Ubiri enclave, has a population of 946 inhabitants living inside the Forest Reserve as an island of agricultural land. This village has been permitted to stay on the basis of a settlement concession politically protected by law, but cannot be renewed.

Acute threat to the forest was identified in hill-tops and steep slopes threatened by poor cultivation, river/stream valleys and banks that need special protection against soil erosion, remnant rainforest patches outside the Forest Reserve and the Forest Reserve boundary threatened by encroachment. Survey results relevant to opportunity for forest product sources indicated that, plantations of exotic trees as a substitute source for forest products are not available in the Nguru mountains. There are only a few exotic tree species around homesteads and these are mainly *Eucalyptus species* and fruit trees. These only serve as a source for fruits, shade and scenic beauty. They are of less importance as a source of other forest products for local consumption. Limited woodlots of *Eucalyptus species* are found around Turiani town, located in the lowland. Furthermore, there is a teak (*Tectona grandis*) Government-owned commercial plantation at Mtibwa in the flood plains of the Wami river. Teak is a high value commercial timber, hence, it cannot be of much direct benefit to local communities as a source of nontimber forest products. Traditional agroforestry which involves retaining some trees in cultivated plots and along boundaries is also practiced. The retained trees are those species combining utility for fodder,

fuelwood, timber and fruits. The harvesting cycle of retained trees depends on need and availability of substitutes.

Problems due to wood collected for local consumption

Woody biomass consumption is one of the important factors with serious impact on forest exploitation as a landuse. In the Nguru mountains the growing population has direct linkage with woody biomass depletion. Population increase is a threat to the forest environment and productive capacity of the land as indicated by the relentless spread of forest encroachment and degradation (Table 4.17), both of which expose the soil to eolian (wind) and hydric (water) erosion. Through soil erosion productivity of the land is reduced, ecological deterioration is increased and the abandonment of the land is promoted. The most widespread local use of woody biomass in the Nguru mountains is fuelwood and building poles. Nearly all households rely on fuelwood to meet domestic energy needs mainly cooking and heating. With present income levels, most households cannot afford alternative sources of energy. In addition to firewood for domestic purposes such as heating and cooking, woody biomass energy is also used for small scale industries such as brick-making, local beer brewing, crops and food curing and drying, iron mongering and baking. All households obtain the wood from the surrounding woodlands and the Forest Reserve. Only a very limited fraction of fuelwood is obtained from small fuelwood plantations around Maskati and Turiani villages. There is not much woody vegetation still left on the slopes outside the Forest Reserve, but some fuelwood is still harvested around farm holdings. There is no doubt fuelwood and poles are obtained from the Forest Reserve especially for those households which live close to the rainforest boundary. The quantity and value of wood consumed locally is an issue further discussed in Monela (1995b).

Biological diversity represents an important resource in the Nguru mountains. The increasing concern for sustainability of both floral and faunal resources and the threat of biodiversity loss as a result of landuse related human activities have made the conservation of biodiversity one of the key challenges in the Nguru mountains. According to the Forest Authorities, local people have fuelwood rights in the Forest Reserve and all forest ranges are open for firewood collection. Collectors are local people from within the area of investigation and firewood collected is rarely transported further. It was observed that, wherever there are trails in the Forest Reserve, there was also fuelwood collection. Those people who cut wood for poles and timber, penetrate much further into the forest than ordinary firewood collectors. Table 4.26 presents trails and trail density in selected parts of the Nguru South Forest Reserve in Mhonda area. The trails were mapped along roads and trails running alongside or parallel to the Forest Reserve boundary, between 0 and 1 km from boundary. Trail density was averaged for the distance the survey line passed at or near the respective forest boundary. Most surveyed parts of the forest showed the presence of well trodden trails indicating the high frequency with which people enter the Forest Reserve for collecting forest products. The trail density was also high, such that there were no long stretches without trails, indicating the widespread use of the area.

Table 4.26. Trail survey results showing trails and trail density in selected parts of Nguru South Forest Reserve in Mhonda area.

Forest range/block	Surveyed boundary length (km)	Number of trails	Trail density (trails/km)	Maximum number of trails per kilometre	Longest distance without trail (km) (if > 500 m)
1	3	7	2.3	3	0.5
2	5	10	2.0	4	1
3	4	13	3.3	6	0.5
4	6	15	2.5	4	1
5	5	12	2.4	5	1.5
6	7	16	2.3	6	2.5
7	4	18	4.5	4	1.5
8	5	13	2.6	5	1
9	6	17	2.8	3	2
10	2	9	4.5	4	0.5
11	8	15	1.0	5	1
12	5	32	6.4	6	1.5
13	5	26	5.2	5	2
14	4	24	6.0	4	1.5
15	6	36	6.0	7	1
16	2	9	4.5	6	0.5
17	3	12	4.0	2	0.5
18	2	7	3.5	4	1
19	4	12	3.0	5	0.5
20	3	15	5.0	3	0.5

Source: Own field data

Firewood collecting pressure is likely to increase in the future with the expansion of Turiani and other semi-urban settlements lying in close proximity to the Forest Reserve. The actual impact and intensity of firewood collection has not been measured in the past. Thus in the present study, firewood observation was conducted by observing and monitoring collectors entering the Forest Reserve at selected entry points. About 7 groups of collectors skirted the place where the researcher was sitting and about 5 resented to respond to questions. The collectors often came in pairs or groups averaging to 6 people, but with a maximum of up to 10 people. Large groups normally split up and the collectors came back out in twos or threes. Those who came alone were mostly men. It was revealed that women walked in groups for security against wild animals or harassment from men especially forest guards.

Table 4.27 presents some results for observation of firewood collectors to illustrate the extent of this activity. About 89 percent of the sampled firewood collectors entered the Forest Reserve for firewood only. About 66 percent of the sampled collectors were women. Both men and women

were observed carrying polewood. However, timber and polewood extraction was mostly done by men. The role of children was in firewood collection. About 11 percent of the sampled firewood collectors were children, mainly accompanying their mothers to the forest.

Table 4.27. Results for observation of firewood collectors in Mhonda area, Nguru South Forest Reserve.

Time of observation at various points (Minutes)	Men	Women	Children	Total number of collectors	Number of collectors per hour	Purpose of entry in the Forest Reserve				
						Fw	P	FW/P	F	H
50	3	0	7	10	12	7	1	1	-	1
75	-	30	2	32	26	32	-	-	-	-
60	4	60	11	75	75	73	2	0	-	-
70	15	5	-	20	17	20	-	-	-	-
265	23	56	9	88	20	80	3	5	-	-
120	5	45	6	56	28	50	2	4	-	-
100	8	21	3	32	19	25	1	3	-	3
60	7	9	-	16	16	12	0	4	-	-
75	2	11	-	13	10	13	-	-	-	-
40	4	4	-	8	12	4	4	-	-	-
55	2	7	2	11	12	11	-	-	-	-
60	7	8	2	17	17	15	1	1	-	-
180	10	24	6	40	13	30	5	5	-	-
150	7	18	-	25	10	20	-	5	-	-
110	5	12	4	21	12	21	-	-	-	-
85	3	7	1	11	8	10	1	1	-	-
70	5	8	3	16	14	16	-	-	-	-
85	2	4	-	6	4	5	1	-	-	-

Source: Own field data

Footnote: Fw = firewood, P = Poles, Fw/P = Firewood and poles, F = Fodder, H = Honey hunting.

To get an impression of the amount of firewood extracted per adult headload, and also to show the nature of the wood collected for firewood, 20 randomly selected adult firewood bundles were examined at the goods scale belonging to Mhonda village Cooperative Society. The results are presented in Table 4.28. The average weight per adult bundle was 21.2 kg and all bundles contained a substantial proportion of large size stems/branches (> 5 cm diameter). None of the firewood bundles contained green wood. Only wood for poles was green and this could be easily distinguished from firewood.

In addition to firewood and poles, a substantial amount of wood is used locally to make tool handles, wooden spoons, cups, pestles and mortars and other products of local craft. The extensive use of woody biomass in the villages in and around the Nguru mountains is one source of tropical rainforest degradation. Unfortunately, the people who rely on woody biomass as the

main source of energy and other local uses, are the rural poor many of whom are ignorant. Consequently, they often do all they can to increase their income in order to survive reasonably, without regard to forest degradation caused by their activities. Many of them are unable to consider the long-term consequences of their actions. This is worsened by the fact that, the bulk of the woody biomass for local use is produced and consumed within the confines of the village as a "free good" where monetary transactions are minimal and consequently much of it goes unrecorded. If excessive forest exploitation will be allowed to continue unabated, it will soon render woody biomass insufficient even for domestic energy needs. This will also preclude even prospects of using biomass energy to make agriculture and small industries more productive.

Table 4.28. Measurement results for firewood bundles in Mhonda area, Nguru South Forest Reserve.

Bundle number	Length (cm)	Weight (kg)	Number of stems		Dry/Green wood
			< 5cm diameter	> 5 cm diameter	
1	115	20	32	6	Dry
2	170	26	28	10	Dry
3	110	22	25	8	Dry
4	120	24	35	3	Dry
5	170	26	29	6	Dry
6	120	18	17	2	Dry
7	80	12	15	1	Dry
8	115	15	16	4	Dry
9	155	23	21	11	Dry
10	100	25	28	10	Dry
11	160	30	25	13	Dry
12	180	35	18	16	Dry
13	95	16	35	5	Dry
14	155	25	25	8	Dry
15	135	20	16	5	Dry
16	90	12	17	4	Dry
17	125	15	15	2	Dry
18	110	17	28	3	Dry
19	160	19	24	6	Dry
20	155	24	20	12	Dry

Source: Own field data

However, the rural poor will continue to rely on woody biomass for a long time in the future. Even if the long-term use of woody biomass is to decline in the future, for example if its substitutes become abundant and cheap enough, woody biomass will still remain one of the important forest products because of its great versatility, which is one of its most attractive features for rural life. The sooner this is realized, the better for forest conservation efforts. For example, the fact that a range of energy conversion technologies already exist, and many are being improved, implies that there is a diversity of solutions available in solving local energy problems to rescue the forests. However, this very much depends on available technology, manpower, resources, needs and a host of socio-politico-economic decisions. It also depends on the local circumstances. All these factors are important in implementing the policy that will reduce the spate of forest degradation and deforestation and so, avoid harming agriculture, environment and society in the long run and ensure sustainable supply of biomass and other forest products.

Problems due to collection of other non-timber forest products

Besides firewood, the rainforest in the Nguru mountains also produce a variety of other non-timber forest products which are basic to the welfare of the people in the area. Different species of local importance were enumerated according to the way the local people make use of various species from the forest to meet their daily needs. The results are presented in Monela (1995b). However, among the important non-timber products are the palm and coconut leaves for weaving and thatching, dyes, oil seeds, herbs for food and medicine, mushrooms, small game, latex such as bird lime, berries and nuts, fruits and bark among others.

The local people often enter the Forest Reserve not always in search of wood, but sometimes simply to collect such non-timber products. Some areas that are considered inaccessible for timber harvesting are sometimes penetrated to collect non-timber products for local use. Survey results showed that, most local people in the Nguru mountains realize that it is prohibited to harvest timber in the Forest Reserve. But they also understand that the law permits, and it is their right to collect non-timber forest products. The uses of various non-timber forest products collected for local consumption are presented in Monela (1995b). Some threats to the tropical rainforest are the outcome of collecting from the forest. A typical example is the frequent occurrence of fire incidence and the presence of several temporary settlements close to the areas where such nontimber forest products are abundant.

4.3.2.6 Problems due to fire hazards

Frequent bushfires is another landuse problem in the Nguru mountains. These frequent bushfires are an important source of damage to the forests in the Nguru mountains and other areas in Morogoro District (Table 4.29). Fires are traditionally used to clear agricultural land on the Nguru mountain slopes and invariably, these bushfires often spread beyond control up to the forest boundary or sometimes slowly penetrate the rainforest. Although the rainforest boundary does not burn readily, yet each year, many trees on the periphery of the Forest Reserve are scorched or killed and gradually the tree cover of the rainforest is reduced and modified.

However, the recurrence of such fires on woodlands is more severe compared to the tropical rainforest because, species composition in the woodlands is altered in favour of more fire resistant species. Such fires are more common and more damaging on the drier slopes in the South and West of the Nguru mountains. In its effort to reduce the impact of bushfires on the rainforest, the Catchment Forest Office has in some areas planted rows of fire-resistant trees for border demarcation. Such trees are the first to be scotched or burn when fires spread towards the rainforest. According to CFP (1994), the main causes of bushfires in the Nguru mountains include: clearing land for agriculture, clearing the land around the fields to keep away vermin, honey collection using smoke to keep away bees and leaving the fire uncontrolled, hunting with the help of fire to drive small animals into the snares or traps and leaving the fire uncontrolled, arson or wanton damage against forest land and the sparks from old-fashioned and locally made firearms used in dry bush. Sometimes burning to sprout new grasses is practiced by those households which possess some domestic animals. Occasionally, bushfires may be started by lightning. Generally, bushfires are often started with some good intentions, but often, it runs out of control and inflicts heavy damage to the rainforest and woodlands. Acts of arson are not very common but do occur as Table 4.29 shows.

Table 4.29. Summary of reported fire occurrences in Catchment Forest Reserves for Morogoro Rural District, 1989-1993

Year	Forest Reserve	Area affected (ha)	Source of fire ¹	Penalty to culprits
Oct. 1989	Uluguru north	1.25	Land clearing	Fined
July 1990	Kitulanghalo	40	Charcoal burners	Prosecuted
July 1990	Kitulanghalo	87.	Land preparation	Prosecuted
Aug. 1990	Uluguru north	3	Land preparation	Fined
Aug/Sept. 1990	Mindu	6	Arson	Released Fined
Sept. 1990	Uluguru north	Unknwn	Land preparation	Fined
Sept. 1990	Uluguru north	2.5	Land preparation	Fined
Sept. 1990	Mindu	2	Quarrying	Fined
Sept./Oct 1990	Mindu	2	Quarrying	Released
Nov. 1990	Mindu	Unknown	Arson	Fined
Mar. 1991	Uluguru north	24	Hunters	Fined
Mar. 1991	Uluguru south	50	Quarrying	Prosecuted
Mar. 1991	Nguru South	15	Quarrying	Prosecuted
Aug. 1991	Uluguru north	5	Land preparation	prosecuted
Aug. 1991	Uluguru north	2	Land preparation	Fined
Sept. 1991	Uluguru north	5	Land preparation	Prosecuted
Sept. 1991	Mindu	6	Quarrying	Prosecuted
Sept. 1991	Uluguru north	6	Land preparation	Unarrested
Set./Oct. 1991	Mindu	15	Arson	Unarrested
Sept. 1991	Ruvu	Unknown	Honey hunters	Given a seminar
Oct. 1991	Kimboza	2	Arson	Given a seminar
October 1991	Mindu	18.	Hunters	Fined
Nov. 1991	Kanga	112	Land preparation	Prosecuted
Nov. 1991	Kimboza	3	Land preparation	Fined
Dec. 1991	Kimboza	1.5	Hunters	Unarrested
Aug. 1992	Kitulanghalo	35	Hunters	Prosecuted
Sept. 1992	Kitulanghalo	15	Charcoal burners	Prosecuted
Aug. 1993	Uluguru north	1	Land preparation	Fined
Sept. 1993	Uluguru north	2	Land preparation	Prosecuted
Sept. 1993	Uluguru north	10	Land preparation	Fined
Sept. 1993	Mindu	20	Arson	Fined
Oct. 1993	Uluguru north	44.	Land preparation	Fined

Source: CFP (1994)

Footnote: 1 Land preparation includes both clearing cultivated plots and new areas.

4.3.2.7 Problems due to clearing of forest for cash crop production

The World Bank Report (1992), argues that encouraging cash crop production is the best way of getting cash into the farm, and without cash the farmer cannot buy the inputs which will enable him to grow more food. It is a good argument in theory, but its reality in practice is questionable. In the Nguru mountains, cash crops on very limited scale are grown on mixed cropping systems. These cash crops (with the exception of sugar cane grown in lowlands) are not grown as monocultures in big plantations. Consequently, they have not been responsible for pushing peasants to marginal lands. Thus there have been neither investments in cash crops nor dedication of best land to highly remunerative crops and marginal land to food production, to which could be attributed the almost total neglect of the peasant food crops.

Low food yields and neglect of cash crops despite their high commercial value have been more a consequence of poor government policies which have also contributed to environmental bankruptcy among the peasants and its accompanied resource depletion (Gibbon, Havnevik & Hermelle 1993). There have also been no adequate marketing and extension support given to food crops for home consumption, hence cash crops have not benefitted food production in the area. Nevertheless, the presence of the Catchment Forest Reserves, the Mtibwa Sugar cane Estates, the Mtibwa Teak Plantations and the Dakawa Rice Farm in the lowlands on the eastern side of the mountains have somewhat played a role in increasing the pressure for land.

4.3.2.8 Problems due to shifting cultivation (slash and burn)

The traditional farming system in the Nguru mountains has been shifting cultivation and one of its main objectives has been to allow exhausted land, the time to replenish while cultivation continues on a fresh more fertile land parcel. Consequently, one of its main characteristics is to get rid of tree vegetation on the land and replace it with bushes and grass which occupy the land during the fallow period. For this reason, shifting cultivation has turned into an ecologically unsound agricultural method of late. Population growth and production for the market have increased the total acreage of cultivation tremendously to the extent that, there is no longer enough space for bush fallow system. In consequence, the fallow period has been shortened to a minimum or totally abolished.

This implies that once land is cleared, it is no longer allowed time to replenish itself as in the past. Shifting cultivation practice was even more threatening on the steep mountain slopes where the pace of soil erosion is faster. The practice was towards the rainforest because peasants believe that, land near the rainforest is more fertile and holds more humidity therefore is more productive. Since there is a sharp contrast between the sparsely wooded land outside the rainforest and the rainforest environment, the forest boundary had been very vulnerable to disturbances from shifting cultivators. The main disturbances have been in the form of fire hazards, felling of trees and encroachment. Vegetation clearing and burning associated with the slash-and-burn technique have been one typical way of encroaching the forest. Therefore, fire has been classified as one of the important threats to the rainforest because every year it destroys large patches of the land both inside and outside the rainforest (Table 4.29). Data to illustrate the

extent of forest encroachment is presented in Table 4.17.

4.3.2.9 Problems due to squatters inside the Forest Reserve

Due to a steady population increase food demand in the Nguru mountains is pretty high. Coupled with degradation of the land already under cultivation the remaining forests and woodlands are subjected to very high pressure for encroachment. Almost each year, some fresh areas of land are cleared for crop production (Table 4.17). The practice is more intense on the heavily populated eastern slopes where people have often deliberately attempted to clear land for crop production inside the Forest Reserve. Sometimes this practice is due to lack of proper forest boundary marks or some people deliberately pretending not able to distinguish between a Forest Reserve and public land boundary. In addition to frequent attempts by the peasants to clear land on the forest borders, there is also the problem of those villages which for a long time have been established within the rainforest.

These enclave villages are Ubiri, Mnembuke, Lulago, Disango, Kibati, Manyangu and Nkombora. Since they are within the rainforest, these villages have no surrounding land into which they can expand. Consequently they suffer from severe land shortage than even on the slopes outside the rainforest. At Ubiri enclave alone there were 4 reported cases of wide encroachment destroying more than 50 ha of Forest Reserve since 1987 (CFP 1994). Such damage could occur because forest staff rarely visit this area. These villages are located at high altitude in areas not easily accessible by the forest staff. Also marking of forest borders from within the forest is not practiced by the Forest Service. This has given some advantage on the inhabitants of these villages to encroach the forest. Furthermore, it is in these villages where cardamon the crop which needs the tropical rainforest to thrive, has been grown in the past and consequently causing more forest encroachment from within. Certainly inaccessibility of such areas poses another constraint to the peasants in terms of transporting their agricultural produce. This is one among several reasons, which have hampered cardamon production.

4.3.2.10 Problems caused by farming in the buffer zone

The purpose of buffer zones is to serve as a transition zone from forest to agricultural land and vice versa, decreasing the pressures on the borders of the forest reserve (Sayer 1991, CFP 1991). It has been a desire of the Forest Service to create buffer zones as part of the protected Forest Reserves in the Nguru mountains. Unfortunately, such efforts were hampered by the lack of funds to carry out forest operations. Because of land pressure, the natural vegetation in the zone adjacent to the Forest Reserve, which earlier served as a buffer zone, has been very much reduced to the extent that peasant cultivated fields are now in contact with the rainforest. Such situation is a result of the increasing scarcity of land in public areas. Under such land pressure, it has become essential to convince the farmers adjacent to the Forest Reserve to adopt better ways of using their fields bordering the rainforest. Incidentally, this has been difficult (CFP 1994). The peasants in the buffer zone have been reluctant to adopt landuses proposed to them such as agroforestry practice or growing woodlots for firewood and building poles. Thus the long term objective of the buffer zones, that is, taking over most of the functions and uses the forest

has, for villagers, been difficult to achieve. Since most of these peasants in the buffer zone are situated at high altitude on the remote steep slopes, they rarely meet with forest extension officers. Therefore, the prospect of changing their landuse patterns is obscured.

4.4 Main factors causing landuse problems in the Nguru mountains

There are many factors which cause landuse problems in the Nguru mountains. For example, some landuse problems such as deforestation and forest degradation are generally a consequence of a complex of processes most of which have been taking place in the Nguru mountains. Based on survey results, field observation and own field experience, landuse problems in the Nguru mountains are viewed as being a result of inter-related forces whereby, population growth along with consequent increased domestic demands for family labour, land, food, forest products and market goods as well as uncertainty (risk), local traditions and beliefs, insecure property rights, land tenure, land scarcity and conflict of interest among landusers, low technology coupled with market and Government failures, international demands and asymmetry, appear as main driving and accelerating forces for landuse problems in the Nguru mountains. Thus landuse problems are a consequence of many interrelated factors caused by complex processes resulting from human social dynamics acting locally or on a wider dimension. These factors range from social, economic, cultural and political forces which are related to each other in multilineal causal chains (Figure 4.2). Landuse problems in the form of forest degradation, deforestation pressure, soil erosion, diminishing crop harvests, clearing land for agriculture, overgrazing, destructive charcoal burning, excessive pole and firewood harvesting, illegal pitsawing, bushfires illegal logging and other detrimental activities are only some of the key consequences of the forces causing landuse problems in the Nguru mountains. Rural poverty and efforts to adapt to economic hardships at the local level through income generating endeavours, have a significant influence on the activities that cause landuse problems. Market and government failures enhanced by international demands and asymmetry, fail to allocate correct price incentives concerning production and consumption especially for environmental goods. Consequently, these are treated in the market domain as "free goods" or "gifts of nature" that can be used at will without compensation which would restrict their use. A consequence is overuse which culminates into creation of landuse problems.

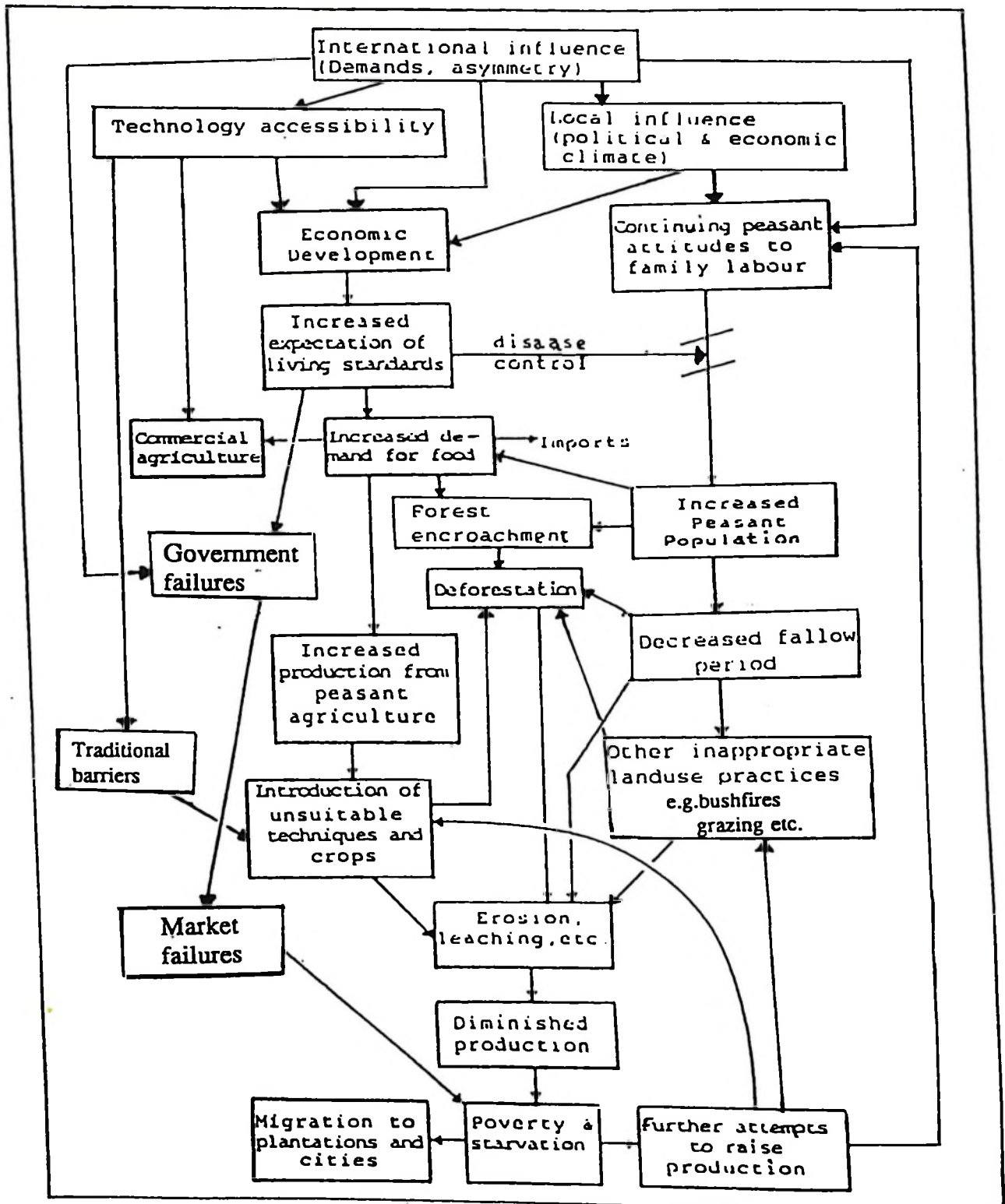

Figure 4.2. Schematic diagram showing the relation between landuse problems and main factors causing landuse problems in the Nguru mountains.

It seems the Government in Tanzania has not been able to control landuse problems through policy measures or coercion. Also the market through automatic control has not been able to do so due to its failure to provide negative feedback loops to check landuse problems in the country and in the Nguru mountains. This is partly due to the widespread market and government failures such as tenurial traditions and policies which provide incentive for poor landuse practices. Vaguely defined, unequitable and uncertain land tenure conditions, undefined property rights, ignorance and traditional barriers add a complicating dimension to landuse problems in the Nguru mountains. Property and tenure rights are systems of authority established by governments or cultural traditions to form a set of rights to control land assets. These strongly affect the bargaining powers of various parties and thereby the distribution of income and wealth. The rural poor, the main agents of land and forest degradation in the Nguru mountains, have unreliable access to credit markets due to the absence of guarantees caused by lack or uncertainty of tenure. The effect of this has been to enhance landuse problems. Local, national and international asymmetry which still prevail has also influenced landuse problems in the Nguru mountains in varying dimensions. International asymmetry has played a major role in enhancing some policy and market failures in Tanzania as a whole, including the study area. The various forces causing landuse problems in the Nguru mountains are further discussed in the sections which follow.

4.4.1 Rapidly growing population

Under the agrarian rural economy, local people in the Nguru mountains have not learnt that big family size is a deterrent to improving the standard of living. Although many households are monogamous, still the majority have very huge family sizes averaging 7 people, incompatible with their level of income. These people reproduce many children to increase the household labour force and also as an insurance against old age. However, the demands of the commercial market have made life very difficult for households with many children. Since these people rely absolutely on the land as the means of livelihood. A large family has also caused fragmentation of the land for distribution among heirs. Such divisions have converted land into non economical parcels. This stresses another negative aspect of population growth that, if uncontrolled, population growth hinders economic development by increasing competition for scarce resources such as land.

The demand for food is also essentially linked to population growth. Population growth has raised food demand and consequently the need for more arable land in the Nguru mountains. The growing population is one single main factor endangering the tropical rainforest and its productive capacity as indicated by the relentless spread of degradation and deforestation pressure. Due to population growth, land for expansion of farming plots has diminished and shifting cultivation practices have become infeasible, hence limiting the traditional farming system. Efforts to intensify agriculture to boost production and yields have also been limited by poverty. Thus the peasants only way to survive has been through landuse practices which degrade the land and forest resources. In consequence, the potential of rain-fed agriculture to feed the growing population in the Nguru mountains has continued to decline. The momentum for population growth in the Nguru mountains is quite high (3.7 percent per year) and consequently the demands on resources especially land will undoubtedly continue to grow and intensify land

pressure, leading to more landuse problems. The factors causing population growth in the Nguru mountains have been discussed in section 4.2.2. The role of population growth in increasing the pressure for land and forest resources was also discussed.

4.4.2 Land tenure system and Insecure land ownership (attenuated property rights)

The land tenure conditions in the Nguru mountains are very much influenced by the land tenure system in Tanzania. The land tenure conditions in Tanzania on the other hand are very much influenced by historical reasons as well as variations in geographic, climatic, ethnic and cultural environments (Mnzava & Riihinen 1989). The present land tenure system provides four main different possibilities of acquiring land for one's use: (a) The Government leasehold, where the Government leases land to individuals and communities for specified periods often 33, 66, or even 99 years. (b) Rights of occupancy, which is often concerned with land developed into agriculture, animal husbandry or for the purpose of service industry, (c) Customary land tenure, in which the ownership of land is gained through inheritance or customary rules among tribes, clans or kinship, (d) Collective or village land ownership, where the land ownership of the village is based on law and thus the land must be surveyed and demarcated before issuance of a certificate of ownership. The village then is entitled to use the land in its best interests. Table 4.30 shows how land is acquired in Tanzania. (Table 4.4 showed for the Nguru mountains). Some land acquisition methods are important than others as can be gleaned from the percentage of households acquiring land by each method. It is important to note that, the above ways of gaining land ownership are not necessarily interchangeable. They are partly historical, not static, are tied with local circumstances and adjust to changing circumstances - climate, migration, population growth, new markets and new needs. Appendix 2 shows a calendar of major events in the evolution of land tenure policies in Tanzania for the period 1974 - 1992.

The land tenure system prevailing in the Nguru mountains is the customary land tenure system which operates within the village land ownership system. Thus land is acquired through inheritance under the traditional law. There is no commercial transactions over land such as land speculation. The peasant's security of land ownership is based on traditional law as title deeds are non-mandatory for the land they use. In this system, land is distributed on the basis of need rather than use and there is no money cost involved in maintaining use rights as is the case in freehold tenure system. Instead, there are time costs, but these are related less to the productivity or scarcity of the land than to the opportunity costs of using this time in other non-market or market production. These opportunity costs will often be minimal for certain household members and can be covered by labour extensive subsistence cultivation. However, this does not imply that, land owned under customary land tenure system can only be used for subsistence production. Where other opportunities for market production are scarce, the land may be used for commercial purposes. Covering opportunity costs of maintaining freehold use rights, on the other hand, requires a minimum value of production per unit area of land. Under the customary land tenure system practiced in the Nguru mountains, there are no land markets. While the absence of land markets has inhibited commercialization, the distribution of land according to need rather than use has prevented good farmers from expanding their operations. Communal land ownership has denied the people security of land title given by individual ownership under

freehold tenure system. It has also denied the people incentive to make long-term investments in the land as well as the means to do so through collateral credit.

Thus lack of security and ability to finance land improvements are important reasons for the low production levels achieved by indigenous farm household in the Nguru mountains. However, it should be noted that short-term improvements in productivity which involve the use of short-term inputs can still be done as these are not inhibited by lack of long-term security of tenure. The fact that a big proportion of land is treated as public land, and that the land under peasant ownership is owned on customary basis without title deeds, have over the years made the peasants irresponsible over the land they use due to the insecurity over land ownership. The consequence is socio-economic problems in agricultural and forestry production systems and in the majority of cases diminishing production and discouraging long term- investments. This has also encouraged shifting cultivation and poor farming practices. The system allows the peasant to open up a new land, use it until it is degraded, then abandon it in favour of new areas where degradation is continued in accordance with the "open access" concept of resource utilization. This type of shifting cultivation is now constrained by unavailability of fresh land. Village land ownership under the "Village land ownership Act" of 1975 has not simplified the situation because land for villages has not been surveyed or demarcated.

Table 4.30. Land acquisition methods in Tanzania

Mode	Average area (ha)	% of total area	% of households acquiring land by this mode
Inheritance	2.1	40.0	46.0
Allocation by village authorities	1.5	28.0	37.0
Clearing	1.05	20.0	20.0
Purchasing	0.55	11.0	13.0
Borrowing or renting	0.03	0.6	2.0
Leasing from government	0.02	0.3	0.6
Other	0.03	0.5	2.0
Total	5.28	100.0	-

Source: World Bank (1992).

One basic feature of the Tanzanian land Law is its dualism. The right of occupancy, the only recognized tenure, is either, (a) a granted right for up to 99 years, subject to conditions as regards development of the land, or (b) the deemed right of occupancy or customary tenure, which subject to use, is held in perpetuity. The second distinctive feature relates to administrative law and property rights which do not give villages opportunity to devise their own arrangements to fit their evolving situations and local knowledge. The top-down approach is used to introduce all government land related initiatives (Appendix 2) and fines and jail terms used to enforce them. The third feature is that there is ambiguity between open access and common property. Public

land is in effect, subject to open access until it is taken under customary or deemed right of occupancy through clearing and cultivation or allocated for development by the government under granted right of occupancy. Such land is often subject to uncontrolled use and degradation. Whether public land should be set aside in reserves, put under village jurisdiction, or left as it is, is a major land policy question. Public land is best understood as all the land between village settlements and their cultivated lands that is not reserved and therefore not under the jurisdiction of a particular Ministry or Agency. The disposition and management of these public lands is of great environmental importance. In the Nguru mountains such land have been abused leading to landuse problems which enhance deforestation pressure.

According to World Bank (1992), "Open access means that there is no effective restriction of access to valued natural resources such as pasture, natural forest, or water. In common property situations, by contrast, access to such resources is shared by the members of the group, such as a village, lineage, or neighbourhood, which has the right and ability to restrict its use by outsiders. Often the group also regulates its members' access to the resources on a spatial, temporal, or individual basis; and this internal governance is strengthened by clear boundaries and membership of the groups, clear rules, sanctions in case of misbehavior, and monitoring and conflict resolution mechanisms". The World Bank (1992) notes that in Tanzania "the insecurity fostered by current land policy has encouraged people to plant trees on agricultural land, whether or not they want them (because they would own the trees and thus develop rights over the land) and has at the same time encouraged them to cut down natural forests to establish a claim to the land, even if they would prefer to maintain those forests as they are". This may seem a contradiction in terms, but that is actually what takes place in most parts of the country. Like in many parts of Tanzania, land in the Nguru mountains was redistributed during implementation of the villagization policy in the first half of the 1970's. However, the land allocated to the villages in the area under the 1975 Villagization Act is not yet surveyed and demarcated. Despite this redistribution of land to villages, yet still ownership of individual plots is still controlled by customary laws except for land used either as open access or common property. For example land used for grazing and also forests and woodlands. The exceptions are small grazing areas near homesteads and trees on farms respectively. Plots afforested (but non-existent) also ought to belong to the owner just like a cultivated field.

Land disputes are not uncommon in the area and the lack of control over the use of land permits one to freely use the land and abandon it at will after degrading it, then move to another area under shifting cultivation. Under customary law any one with the energy to clear land could obtain land by clearing it, provided he had the permission of the headman, the lineage authority, or the individual who exercised effective authority in the area. The investment of labour gives the land value and creates tenure which is held by the clearer and his heirs. This practice is incompatible with sustainable use of land. Meanwhile the lack of sufficiently defined village boundaries have also been the source of land conflicts between bordering villages. Disputes between villagers and between villages are due to the fact that the increasing value of land has also inevitably led to increased competition. The resolution of land conflicts is complicated by the differing normative orientations and interests of the responsible institutions and by the varied issues they have to deal with: inheritance, allocation by the village council, clearing, purchase,

loans, rental, share cropping, regaining land lost during villagization, allocation under granted right of occupancy and squatting. Traditionally, it is in the man's name that ownership of the land is recognized. Thus land is still controlled by the male household head and with it the decision of what to grow, to sell and how to invest. Since women do not own land they work on their husbands fields and depend on his decision to remunerate them for their labour. This has impact on how women treat the land. The whole household relies on its land to feed and get some surplus for sale to get income. Sons are entitled to inherit this land but not females. There is no selling of land as a commodity since it has to be passed from one generation to the next. The influence of commercial markets in this regard has been minimal. Peasants are unwilling to sell the land because their entire livelihood is tied to it. The land tenure system in the area is not likely to influence investment on the land because with prevailing income levels, people value present consumption possibilities more than future consumption. Thus every household strives to work on the concept of "best land use" to meet its immediate needs especially food.

4.4.3 Traditional barriers

It is undisputable fact that the traditional landuse systems we see today in the Nguru mountains, have evolved over a long period of time and there is reason to believe that they have won the test of time. Consequently, these landuse systems have sustained the people in this area for many years. However, the evolution of the commercial market and its linkage with agriculture has outmoded the efficiency of some aspects of such traditional landuse systems. The continued adherence to some aspects of the traditional landuse systems is one source of landuse problems and has also contributed to the decline in land productivity leading to most peasants in the area being very poor. Adherence to old-fashioned cropping systems and resentment to adoption of new seed varieties because of inability to buy them are among the typical problems related to traditional farming.

Shifting cultivation, the slash-and-burn technique often used to clear the farmlands, lack of soil conservation measures, reliance on manual labour, uncontrolled child birth, local harvesting and storage methods are typical examples of traditional barriers that enhance landuse problems. For example, the slash-and-burn technique of land clearing for cultivation contradicts with intensive farming practices whereas shifting cultivation system is no longer suitable under contemporary population growth. Often the fire used to clear the land runs out of control and destroys forest cover together with its flora and fauna, both of which have high biological and ecological importance especially in nutrient recycling and humus formation. However, not all traditional techniques are not suitable. Those which are appealing under the contemporary situation should be improved and retained. For example mixed cropping system or staggered planting to avert risks of crop failure.

4.4.4 Different priorities between land users

The conflict of interest between different landusers in the Nguru mountains is one main factor enhancing landuse problems. While agriculture expansion requires more land, some land suitable for agriculture is occupied by forestry hence is no longer available for agriculture. Livestock

grazing also competes for land with both agriculture and forestry and when excessive it has deleterious effects on these landuses. This competition is further sharpened by the fact that, land rights in Tanzania protect agriculture and forestry but not grazing rights. Although peasants practice some form of mixed production systems that embrace all the landuse systems, still the level of integration among the peasants is very traditional to reconcile the landuse conflicts. Comprehensive land use planning needed to resolve these landuse conflicts is not practiced. This has enhanced landuse problems in the Nguru mountains

4.4.5 Ignorance and lack of effective extension service

There is lack of an effective extension service to educate peasant farmers in the Nguru mountains on the importance of various land uses to their welfare. Survey results showed that only about 10 percent of respondents conceded to receive services of extension staff in the Nguru mountains. Lack of effective extension service is one of the important shortcomings in Government initiated rural development programs in Tanzania (Mgeni 1992). One potential problem in the Nguru mountains is that Government extension agents who work among the peasants seem to lack the necessary knowledge to educate the people on integrated landuse systems as well as landuse conflict resolution. They seem to concentrate on sectoral-oriented approach whose tendency is to enhance conflict between landusers. Extension agents sometimes give local farmers contradicting information between sectors or within their own sector thus eroding peasant's confidence on them. This behaviour seem to be partly due to lack of proper extension knowledge among local forest staff. Most of the extension staff, who through their activities, interact directly with peasants, seem to know very little on the background of the forest problems directly related to peasant life.

For example, most local foresters seem to have the attitude of regarding peasant farmers as main culprits threatening the forests. Although this may be true, yet this attitude when directly exposed, it offends the local people and jeopardizes their cooperation. The lack of transport and funds for forest extension has also contributed to poor extension service because the local foresters have often failed to visit some areas under their control. Poor extension service in the Nguru mountains have reduced the forester's position to the role of the policeman instead of a change agent. Therefore, as a "policemen", the forester has constantly harassed the people instead of eliciting their participation in the utilization and protection of the resource upon which their life depends. In extreme cases, this attitude has led peasants to view Forest Reserves as a property of Government for which they have nothing to lose if they are destroyed. This is certainly contrary to the reality because, the Government protects forests in the interest of society of which the peasant farmers in the Nguru mountains are part and parcel. Through their actions and attitudes, irresponsible and corrupt foresters sacrifice the interests of the Forest Service and sometimes alienate peasant farmers from the forest activities. Some forest staff have made peasants to view them as corrupt people because, they have been known to collaborate with culprits to facilitate illegal commercial harvesting activities especially with pitsawyers. The sacking in 1992 of the Turiani Forester, one Mr. Abeli Ndaru, due to collusion with illegal pitsawyers is the case in point. Such foresters have given to the local people the impression that, the Government is more concerned with forest exploitation compared to forest protection.

The inability of the forest staff to properly carry out their function as protectors of the forests is mainly a result of lack of funds and personnel. Local Foresters in the Nguru mountains live in villages situated far away from the forest borders. Moreover, they are assigned to control a huge forest area without proper working facilities such as reliable transport. On the other hand, the local people sometimes promote bad behavioral patterns among the forest staff by not reporting irregularities in forester's activities. The dilemma is that the peasants themselves are involved in illegal activities and sometimes bribe forest attendants to silence them. This has created mistrust on both parties and hence conflict of interests in land use. Some negative peasant behavior is direct resentment to foresters view that, peasants have only to be told what to do and what not to do, instead of viewing them as rightful participants in forest management. Sometimes it is a result of the pressure to survive.

4.4.6 Government failures

Although small farmers and shifting cultivators are the main agents of land use problems, the problem basically starts with the perverse and inequitable agricultural policies by the government. The direct or indirect pressure on land caused by structural factors is tremendous. These include removal of subsidies, pricing policy, inequalities of access to arable land, lack of non-farm sources of employment and other perverse and inequitable agricultural policies (FAO 1991). The impact of these interacting with other factors such as population growth have played a significant role in causing land use problems in the Nguru mountains. The role of Government policies in shaping the direction of land use practices cannot be underestimated. In Tanzania, many policies with direct impact on peasants and land use have been promulgated from time to time (Appendix 2). According to the World Bank (1992) for example, due to dualism of the land Law in Tanzania, its administrative emphasis and ambiguity, the Government has been embroiled in a multitude of attitudes, tendencies and actions related to land use. One consequence of this situation is a mosaic of more than 36 Ordinances and Acts, which lack both comprehensiveness and coherence. To move toward a more stable system of secure land property rights based on land tenure and market allocation, grounded in Law and upheld by the courts, still presents an important and difficult challenge to Tanzania authorities. Immediately after independence in 1961, the Government announced that land was a public property and an individual has a right over the land only when he was using it. This policy was reiterated by the Arusha declaration which underlined Tanzania's path to Socialism in 1967. The statement by the Declaration that land is a public property converted the land into a "common property" and sometimes "open access" upon which no one has direct responsibility. The result was abuse of land through misuse and mismanagement throughout the country.

The policy indirectly encouraged poor land use practices such as shifting cultivation, overgrazing, deforestation and also discouraged investment on the land. The consequences of such land misuse and mismanagement are the fore-runners of the land use problems we see today in Tanzania and in the Nguru mountains. Typical examples are the problems of soil erosion in Kondoa and Shinyanga where due to the intensity of the problem, the Government in collaboration with international funding agencies such as NORAD initiated land rehabilitation programs. Despite these efforts the situation still remains alarming and more attention is still needed to alleviate the

situation. The Top-down approach practiced before the Decentralization Policy of 1972 had already taken its toll in creating landuse problems. This approach created negative attitudes among peasants on the use and protection of resources. Peasants were uncomfortable with the approach of telling them what to do and what not to do (Mgeni 1992). This kind of approach perpetrated a popular view among some government agents that peasants are culprits resenting Government policies hence must be coerced. This made peasants to feel that they have no responsibility to protect public resources such as forests and land. Different marketing policies especially on agricultural crops have also adversely affected the peasants. For example, state expenditures on agriculture declined since 1980s, commodity prices have frequently been reviewed in favour of the urban sector, peasants crop disposal channels have been very unreliable and many times crops have been bought on credit leaving peasants with little to do, low farmgate prices incompatible with prices of agricultural inputs have reduced peasants ability to produce let alone purchasing their other needs, farm inputs supply has equally been very erratic (Tibaijuka 1990, World Bank 1992, Gibbon, Havnevik and Hermelle 1993).

There are many other Government policy interventions which have affected peasants more than any other sector. One main reason for such Government attention on the peasant being that the country's economy is agro-based. Ironically, the Government has favoured the urban sectors such as commerce and industry at the expense of agriculture (Chachage 1992, Gibbon, Havnevik and Hermelle 1993). Nonetheless, the main reason for the Government's unfavourable policies towards the peasants is that the peasants are easy to manipulate and with the little individual or collective power they have, cannot affect the Government (FAO 1991). Ostensibly this is the group which need to be helped to raise its standard of living because it forms the majority in Tanzania and is the major force in the country's economic backbone, smallholder agriculture. While some of the poor Government policies were bred internally, others have been the outcome of the international monetary system. A typical example of externally initiated policies are the Structural Adjustment Programs (SAP's) used as a means by the World Bank to impose macroeconomic policies on developing countries such as Tanzania. These were aimed at fostering policy reforms in terms of structural adjustments which would achieve lasting improvement in the balance of payments while avoiding excessive cost in terms of lower growth and equity (FAO 1991, Gibbon, Havnevik & Hermelle 1993).

These certainly have adversely affected the peasants. For example in the bid to reduce Government spending (budgetary discipline), subsidies on farm inputs such as fertilizer which affect powerless peasants were removed instead of subsidies on consumer goods which affect the powerful urbanites. Peasants who could not afford fertilizer when it was subsidized were now put in a position of not even thinking about it. This certainly enhanced marginalization of peasants and encouraged them to further degrade the land at their disposal. Such reforms also gave priority to export oriented products which favoured cash crops and neglected food crops. This was effected by the deliberate imposition of a particular producer price (Somogyi 1989). Another example relates to overvaluing of the Tanzania currency, the shilling. This reduced international competitiveness of Tanzania's exports at international markets and thus reduced the country's ability to earn foreign exchange needed to import goods for both peasants and urban people. This translated into exorbitant prices for the few imports that entered the country and the peasants

suffered most as a result of market goods shortage (*ibid.*). Thus peasants found themselves caught in a situation where they were unable even to feed themselves let alone buying market goods. Such policies therefore have played a significant role in sharpening landuse problems. By degrading agriculture through some of its policies, the government has enhanced some landuse problems.

4.4.7 Market failures

The socio-economic setup in Tanzania has been in favour of urban centers despite claims by the Government that the rural areas, where the majority of people live, should be the focus of development efforts. The impact of such situation prevails also in the Nguru mountains. By placing the best infrastructure and inputs for economic growth away from the rural areas, peasants poverty has been enhanced. In so doing, the peasants have been alienated from the economy and hence marginalized. Peasants in many places have always been the victims of discriminating commodity prices, lack of finance, unreliable crop disposal channels, labour shortage due to rural-urban migration of the youth, untimely supply or lack of inputs, late payments for crops sold on credit, removal of farm subsidies, Government interference, and so forth (FAO 1991). The depletion of resources and degradation of the land which we can see today in the rural areas such as in the Nguru mountains, seems to be the outcome of the peasants struggle for survival in the climate of many socio-economic actions acting against their favour. Therefore, the question of protecting the environment and practicing sustainable landuse practices is difficult to comprehend among the destitute peasants who have every reason to believe that their survival now is more crucial than protecting the environment for the future.

Another dimension of market failure is that it is the classic cause of under-investment, where the market forces are not able to secure the economically correct balance of land conversion and forest conservation. An underlying assumption is that there is an economically optimum rate of deforestation and land degradation, which is not zero. Local market failure in the Nguru mountains arises because those who convert the land do not have to compensate those who suffer the local consequences of that conversion. Moreover, the rate of return to forest and land conservation has been distorted by what in economics is referred to as "missing markets". What this means is that the systems of habitats and species in the tropical rainforest serve valuable functions which are not marketed. Effectively, then, no-one values these functions because there is no obvious mechanisms for capturing their values. Local market failure describes this phenomenon within the context of the country or local area, in this case Tanzania and the Nguru mountains. For example, conventional economic approaches to the valuation of forests have often failed to account for the nontimber forest products and services in forest management and investment decisions. In many cases, the only product of tropical forests which has been considered of economic value is the timber produced. However, a whole range of nontimber forest products, including fruits, latex, and fibres, as well as the environmental and carbon storage have not been valued. Environmental economics attempts to overcome this by considering Total Economic value (TEV), a subject which is further discussed in Monela 1995b. Basically this concept aims to cover the range of different uses and services associated with an environmental asset, in this case land and the tropical rainforest (Adger & Brown 1995).

4.4.8 Poor farming technology and lack of farm inputs

One of the important factors that have led to poor landuse practices in the Nguru mountains is the lack of improved technology in farming systems. The principal energy source in the Nguru mountains is human muscle. Animals are rarely used and tractors are exclusively used in state-owned farms located in the lowland areas along the Wami river. The reliance on human muscle implies that energy demands for prolonged execution of agricultural activities are rarely satisfied. The family labour force is usually forced to do very strenuous work especially during the rain season when agriculture is at its peak. Yet the outcome of this labour input is often non-commensurate with the input. Thus greater efforts are needed to develop the traditional equipment and tools by means which evaluates, designs and produces the necessary tools at affordable and local level in terms of price and technical knowhow needed to operate them. This is because appropriate technology minimizes the potential dangers associated with landuse and raises productivity at low cost (Solberg 1988).

However, it may be important to note that technology represents a link between the natural and social systems and may or may not result in the optimum management of the natural resources. There are many cases of the correct and incorrect application of technology and in those cases where there have been wrong application of technology, it has been responsible for many environmental problems of which land degradation and deforestation are typical. Moreover, introduction of appropriate technology should not imply discarding the traditional technologies developed by the local communities but should compliment them because these have been proven over long periods of trial and error and therefore represent proven basis for the sustainable management of natural resources. As there is no limit to technological solutions to landuse problems, endeavors to find most appropriate technology have always been in pursuit although it is understood that technology *per se* is not always the panacea to solving landuse problems. It has to be supplemented by an adequate basic infrastructure and even more importantly to achieve the enthusiasm of the people and their decision to participate in the process of social transformation (Holden 1991). However, this endeavor in the Nguru mountains has often been complicated by social, economic, and political limitations. Some specific restrictions on the utilization of technology in the Nguru mountains are lack of capital due to poverty, lack of effective extension service, lack of trained personnel, lack of enthusiasm to social transformations, lack of basic infrastructure, marginalization of the peasants, lack of motivation and cultural barriers.

All the landuse systems require the availability of certain inputs such as credit, fertilizers, implements and mechanization, seeds, chemicals and so forth, in order to improve productivity and prevent land degradation. Unfortunately the most degrading landuse systems require high investment to rectify the situation. In Tanzania farm inputs have been among the important elements in the structural adjustment programs proposed by the World Bank (Somogyi 1989). In the Nguru mountains land productivity has been declining due to poor farming practices and lack of farm inputs. Extensive agricultural production systems with low productivity per unit area and per unit time are most widely practiced as a result of lack of means to practice intensive agriculture. Shifting cultivation is still practiced although at diminishing extent. Fertilizer,

improved seed and chemicals are also used to a limited extent. Some farmers cannot afford even the most basic tools such as a hand-hoe due to high prices. Poor Government policies and institutional factors have been one main cause of this situation. Thus a vicious circle of poverty has been operating in the area with ever-worsening depletion of resources and declining standard of living of the peasants. A plan of action is needed to induce a gradual change to more intensive production systems with greater unitary yields. The methods to be chosen must be acceptable to the people. Security in the improvement of the standard of living would motivate the people to work with enthusiasm and for young people it will enable them to stay within the community hence reducing the massive migration to urban centers.

Associated with the poor farming technology is lack of soil conservation measures. The lack of soil conservation measures on land subjected to continuous use with poor implements is one major reason for quick decline in soil fertility and decline in crop harvests in the Nguru mountains. Nutrient deficiencies that are most likely to occur on the mountain slopes after several years of cultivation center on nitrogen, phosphorus and sulphur which is typical in most well drained tropical alfisol soils. But such deficiencies are less pronounced where there is organic matter accumulation as in the rainforest environment. The main cause of nutrient loss is soil erosion mainly caused by surface runoff. Land on sloping ground on the slopes is more prone especially after it has been exposed by clearing vegetation. Also poor farming practices without practicing soil conservation measures such as terracing, strip cropping, contour cultivation, minimum tillage and the planting of trees and grasses to protect the soil contribute to this problem. The impact of not controlling soil erosion for many years has led people to practice bush fallow/shifting cultivation which causes deforestation. Expansion of cultivation under this system has accelerated soil erosion by opening up new land and exposing it to erosion agents. In this case, the demand for more food crops has increased the risk of sacrificing land and its eventual conversion to marginal land. Poor practice of soil erosion control measures can be attributed to lack of effective extension service to advise the farmers, the inability of the poverty-stricken farmers to install needed control measures, the uncertainty about the short-term benefits of conservation practices and absence of good research information specific to the area. There is also lack of political will by government to assign high priority to a problem that seldom is dramatic and wreaks its damage slowly.

4.4.9 Uncertainty due to pests, diseases and vagaries of climate

The tropical climate presents yet another major problem for crop production. Due to unpredictable rainfall the feeding of the people from the land every year is also unpredictable. The unpredictability of the rainfall is one major factor with a direct effect of tropical climate on agriculture. The climate does some obvious physical damage to food crop production in the area due to lack of soil conservation measures. This eventually translates indirectly into forest damage. In years with heavy rainfall it blasts away the lighter, more fertile humus on the farms. When there is no sufficient rainfall the wind blows the humus away and the sun dries it out, leaving heavier sand behind or bare rock. There are patches within the rainforest on the eastern slopes of the Nguru mountains where, there are no trees or bushes and close observation reveals that, this area has very thin layer of soil, below which is the solid rock.

All this explains why there is need for concern about fertility and physical properties of the soil in the Nguru mountains. Peasants discovered that fertility was quickly used up and could be replaced only by replenishing humus and soil nutrients; the important trick was to use the soil in such a way that it was not physically destroyed through bush fallow/shifting cultivation. Unfortunately that system of farming is no longer feasible under current population increase. Thus many peasants have been pushed to the more precarious environments. The outbreak of agricultural crop pests and disease is another important factor which affect farming in the Nguru mountains. Pests and disease frequently affect the crop yields. Maize stalk-borers and Cassava Mealy Bug are among the important pests in the area. Also swarms of other insects mainly red locusts has occurred in the past. A variety of insects sometimes breed in the area. The fact that the peasants cannot afford to use pesticides aggravates the situation. Sometimes the main staples are attacked to the extent that when the impact of other factors such as inadequate rainfall come into play, famine among the peasants becomes a reality.

4.4.10 Fragmentation of land and diminishing parcel size

Large family size is another important factor related to land use as it affects land ownership and distribution. Under the customary land tenure system prevalent in the Nguru mountains, there is always the problem of land fragmentation in order to distribute it to other members of the family who have matured. On the average a Nguu household traditionally owns 2.5 ha of farming land. The diminishing size of the parcel and its low productivity are causing some peasant family members especially male youths, to look for new cultivable land or seek alternative activities and temporarily or totally abandon the parcels allocated to them by the family. The land parcels that are abandoned produce low-remuneration marginal lands, which promote degradation through soil erosion.

On many occasions soil erosion affects various parcels and necessitates the need for collective effort to control it before land is rendered useless. Often such collective efforts are never forthcoming and in consequence the parcels are left to deteriorate. In such situation, new fresh, fertile land is needed and when it cannot be found, the peasants consider the presence of the Forest Reserves in their vicinity as the main reason why they cannot expand their farms. The consequence is to see the Forest Reserve as a Government imposed restriction on their legitimate right to use the land. Nevertheless, some peasants still observe the Forest Reserve borders for fear of prosecution. This to some extent, checks encroachment of the Forest Reserve for agriculture.

4.4.11 Peasant conviction that fertile arable land is in the forest

Some of the most important needs of the peasants include: the need for more land to grow food crops to avert effects of declining soil fertility, the need for more land for heirs to inherit following population growth, and the need for various forest products whose demand can no longer be met from trees outside forest due to degradation and deforestation. Peasants have not developed strategies for alternative means to meet these needs. Since the need for more land to grow food crops supersedes other needs, it has led the peasants to feel that the forest has taken away their basic rights of access to land presently occupied by Forest Reserve. Coupled with the

lack of an effective extension service to educate the people, and the harassment that forest personnel impose on peasants, negative attitude towards the forest has been slowly building up. In the minds of some peasants, the natural forest is nature's gift to them for free use to sustain their life. Thus, they feel that they should be allowed to clear fresh fertile land to open up new plots for cultivation just like they have done in the past for the currently cultivated fields.

4.4.12 People's concern for the fulfillment of immediate domestic needs

Peasants see in the first place, their immediate needs rather than future ones. The quest to fulfill immediate needs is among the main driving forces for the peasant's behavior which seems incompatible with sustainable land use. In the Nguru mountains, the majority of the peasants are very poor. The struggle for survival involves a bitter interaction with the natural environment from which necessities such as fuel wood, building poles and some basic foodstuffs are obtained. This implies that depletion of resources will continue as long as people's immediate needs are not fulfilled. Under the current stress imposed by poverty and lack of necessary education on sustainable use of resources, the peasants should not be expected to act according to neo-classical economics rationally.

5.0 CONCLUSIONS AND RECOMMENDATIONS

The discussion in this report gives some insight on the importance of the Nguru mountains in the socio-economic welfare of the people who live in the area. The people in the Nguru mountains put heavy dependency on the tropical rainforest for their survival. However, through their poor land use practices they threaten the tropical rainforest and agricultural development. They have been compelled to act in this way because of the pressure to survive under poverty. This study has identified the main land use problems with reference to agriculture and forestry in the Nguru mountains. It has also identified the main factors causing land use problems and recommended ways to reduce land use problems in order to prevent forest degradation and deforestation. It has underlined the role of ecological and socio-economic factors in shaping the existing land use practices which have influenced land use problems and factors causing land use problems in the Nguru mountains. The study led to the following conclusions.

The major land uses in the Nguru mountains are agriculture and forestry. The agriculture is dependent on rainfall, growing mainly a variety of food crops using traditional farming practices. Forestry is mainly conservation forestry, but also supplies local communities with both timber and nontimber forest products. Relative to other land uses such as settlements and grazing, agriculture and forestry have contributed most to the prevailing land use conflicts in the Nguru mountains. The main land use problems in the Nguru mountains are: deforestation pressure through encroachment for agriculture, forest degradation through excessive forest product exploitation, frequent and uncontrolled bush fires, land degradation and soil erosion due to poor farming methods caused by poor farming technology and lack of farm inputs, diminishing crop harvests, squatters inside the Forest Reserve, farming in the buffer zone around the rainforest and non-adherence to forest control measures. The impact of these land use problems on the rainforest have been more severe on lowland rainforests where high rates of rainforest conversion to agriculture and other land uses were observed.

There are many factors which cause land use problems in the Nguru mountains. For example, some land use problems such as deforestation and forest degradation are generally a consequence of a complex of processes. Based on this study, the main factors causing land use problems in the Nguru mountains are inter-related forces and these are as follows: population growth; land scarcity; search for market goods; increased domestic demands for food and forest products; poverty; lack of knowledge; lack of an effective extension service; market failures such as breakdown of traditional management systems due to commercialization of demand for resources; government failures such as inefficient government policies; risks and uncertainty in farming (pests, diseases and vagaries of climate) insecure land rights under customary land tenure system, traditional or cultural barriers, conflicting objectives between land users; failure to control protected areas such as Forest Reserves; decline in forest product supply and lack of income from outside forestry and agriculture. International demands and asymmetry, also appear as main indirect driving forces for land use problems in the Nguru mountains. The influence of these various forces vary from local agents to those with a wider dimension beyond the local boundaries. The land use problems and factors causing them form a system causality which relate them and can be used to describe the cause-effect phenomenon regarding land use problems.

From this study, it seems the government has not been able to control landuse problems through policy measures or coercion. Also the market has not been able to do so due to its failure to provide negative feedback loops to check landuse problems. This is partly due to the widespread market and government failures such as tenurial traditions and policies which provide incentive for poor landuse practices. Vaguely defined, unequitable and uncertain land tenure conditions, lack of knowledge and traditional barriers add a complicating dimension to landuse problems in the Nguru mountains. The rural poor, the direct agents of land and forest degradation in the Nguru mountains, have unreliable access to credit markets due to the absence of guarantees (collateral) caused by lack or uncertainty of tenure. The effect of this has been to enhance landuse problems.

Since the welfare and survival of the people in the Nguru mountains are inextricably linked with agriculture and forests, they must improve current landuse practices in order to come to terms with the reality of resource limitation and carrying capacity of their land and forests. Wise management of land and forest resources requires appropriate landuse practices to alleviate landuse problems in order to improve the standard of living and preserve the biological systems especially the tropical rainforest upon which they depend. The strategy recommended requires the following steps: landuse planning at household farm level for efficient use of resources and integrated planning to harmonizing conflict between land users, measures such as family planning to control population growth, education to enhance change of attitude on resource use by overcoming communication breakdown between resources users and protectors through direct dialogue and community involvement, giving some specific rights to property in reserved forests and benefits to villagers to meet their needs while protecting the resources, improving traditional landuse systems and traditional knowledge, incorporate agroforestry in farming systems, removal of institutional barriers to wise landuse by government through appropriate policy changes, and improvement of rainforest management methods to enhance forest protection.

Several aspects related to rainforest degradation and landuse are pertinent for further research. Based on the experience from the present study, the following topics may be suitable for further research:

- Landuse-related government policies that encourage landuse problems and deforestation pressure
- Conflict between indigenous land use systems and sustainable forest management
- Possible connection between deforestation and technology change in the Nguru mountains
- Effect of community participation in planning on sustainable forest management
- Evaluation of linking protection of the rainforest with the local communities
- Role of indigenous management systems in forest conservation
- Time and labour resources, society and ecology: the capacity for human interaction with the tropical rainforest
- Trading efficiency for flexibility in indigenous landuse systems: any costs to the environment
- Negative effects of indigenous land tenure systems on rainforest protection
- Balancing forest protection and human welfare
- Public forest land: should it be put under village jurisdiction or be left as open access land
- Forest production through conservation: a strategy toward village-based participatory rural development

- Use rights in the rainforest and their impact on protection
- Impact of donor funding on tropical rainforest management in Tanzania: some experiences from the Catchment Forestry Project
- Tenurial, gender relationships and property rights with regard to sustainable rain forest exploitation for timber and nontimber forest products
- Effect of management practices on sustainability and biodiversity of nontimber forest products

REFERENCES

- Adger, W.N. and K. Brown 1994. Landuse and the causes of global warming. Centre for Social and Economic Research on the Global Environment. University of East Anglia and University College London, UK. John Wiley & Sons, 271 pp.
- Ahlback, A.J. 1986. Industrial plantation forestry in Tanzania: Facts, problems, challenges. Ministry of Natural Resources and Tourism, Planning Division, Dar es Salaam. 197 pp.
- Ahlback, A.J. 1988. Forestry for development in Tanzania. Swedish University of Agricultural Sciences, International Rural Development Center, Uppsala, Working Paper No. 71, 116 pp.
- Ahlback A.J. 1992. Why and How to mobilize all rural people of Tanzania to tree planting. A PhD. thesis submitted to the Faculty of the Graduate School of the University of Minnesota. 408 pp.
- Awadalla, G.W. 1970. A brief explanation of the geology of QDS 146 (Kwekivu), QDS 165 (Mvomero), QDS 147 (Mziha) and QDS 166 (Turiani), Mineral Resources Division, Ministry of Minerals, Dodoma (unpublished).
- Axelrod, D.L. & P.H. Raven 1978. Late Cretaceous and tertiary vegetation history of Africa. Biogeography and ecology of Southern Africa. In M.L.A. Werger (ed), Junk, den Haag.
- Beets, W.C. 1990. Raising and sustaining productivity of smallholder farming systems in the tropics: a handbook of sustainable agricultural development. AgBé Publishing, Alkmaar, Holland. 711 pp.
- Birdsall, N. 1988. Economic approaches to population growth. In Chenery, H. & Srinivasan, T.N. (eds.): Handbook of Development Economics, Vol I. North-Holland. Elsevier Science Publishers. The Netherlands. p. 477-542.
- Bjørndalen, J.E. 1991. Potential for sustainable management of the Tanzanian rain forests and their biota. Review paper. Department of Forest Biology Sokoine University of Agriculture, Morogoro, Tanzania. 61 pp.
- Bjørndalen, J.E. 1992. Tanzania's vanishing rain forests-assessment of nature conservation values, biodiversity and importance for water catchment. Journal of Agriculture, Ecosystems and Environment, 40:313-334.
- Bjørndalen, J.E. and T. Pócs, 1991. Application of vegetation maps for monitoring rain forest catchments in Tanzania. In J.E. Fallinski (ed.), Vegetation processes as subject for geobotanical maps. Phytocoenosis-supplementum cartographiae geobotanicae.
- Boserup, E. 1965. The conditions of agricultural growth: The economics of agrarian change under population pressure, London, Allen and Unwin Ltd., 124 pp.
- Boserup, E. 1990. Economic and demographic relationships in development. The Johns Hopkins University Press, Baltimore and London. 307 pp.
- Brady, N. 1990. The nature and properties of soils. 10th edition. Macmillan Publishing House Co. Inc, N.Y. Collier Macmillan Publishers, London. p. 497-515..
- Brenam, J.P.M. 1978. Some aspects of the phytogeography of Tropical Africa. Annals of Missouri Botanical Garden, 65:437-478.
- Bromley, D. and M.M. Cernea 1989. The management of common property natural resources. Some conceptual and operational fallacies, World Bank Discussion Paper No. 57. Washington D.C., World Bank.

- Bromley, D.W. 1991. Environment and economy. Property rights and public policy. Blackwell, USA/UK.
- Bunce, R.G.H., C.J. Barr and R.M. Fuller 1992. Integration of methods for detecting landuse change with special reference to Countryside Survey 1990. In: Whitby M.C. (ed.), Landuse change: The causes and consequences, ITE Symposium No. 27, London, HMSO, pp. 69-78.
- CFP, 1991. Managing the catchment forest reserves: Who is to be involved? A socio-economic study prepared for the Catchment Forest Project, Forestry and Beekeeping Division, Dar es Salaam, Tanzania. 35 pp + appendices.
- CFP, 1994. Morogoro Region Catchment Forestry Project, Morogoro.
- Chachage, C.S.L. 1992. Forms of accumulation, agriculture and Structural Adjustment in Tanzania. Paper for the Institute of African Studies, Uppsala, 15 pp.
- Chamshama, S.A.O.; V.R. Nsolomo & A. Persson, 1990. Human impacts on the forest vegetation of the Nguru mountains, Tanzania. In I. Hedberg & E. Persson (eds.), Research for conservation of the Tanzania catchment forests. Proceedings from a workshop/seminar held in Morogoro, Tanzania, 13-17 March, 1989, Uppsala, pp. 150- 154.
- Clark, C.W. 1976. Mathematical bioeconomics. The optimal management of renewable resources New York: Wiley InterScience.
- Ciriacy-Wantrup, S. and R. Bishop 1975. Common property as a concept in natural resource policy. *Natural Resources Journal* 15:713-29.
- Coetze, J.A. 1964. Evidence for a considerable depression of the vegetation belts during the upper Pleistocene on the East African mountains. *Nature* 204.
- Commons, J.R. 1968. Legal foundations of capitalism. Madison: University of Wisconsin Press.
- Dahlman, C.J. 1980. The open field system and beyond: a property rights analysis of an economic institution. Cambridge: Cambridge University Press.
- Dasgupta, P. 1982. The control of resources. Basil Blackwell Ltd., Oxford. 215 pp.
- Deweese, P.A. 1989. The woodfuel crisis reconsidered: Observations on the dynamics of abundance and scarcity. *World Development* 18:513-27.
- Due, J.M., P. Anandajayasekeram, N.S. Mdoe and M. White 1984. Beans in the farming system in Langali and Kibaoni villages, Mgeta area, Morogoro Region, Tanzania. Economic Research Bureau (ERB), University of Dar es Salaam. ERB Paper No. 84.2, 46 pp.
- EIU, 1994. Country profile Tanzania Comoros 1994-1995. Economist Intelligence Unit, 68 pp.
- FAO, 1984. Land evaluation for forestry. FAO forestry paper No. 48. pp. 36-120.
- FAO, 1989. Guidelines for land use planning. FAO, Rome. 121 pp.
- FAO, 1991. The impact of stabilization and structural adjustment policies on the rural sector. Case studies of Cote d'Ivoire, Senegal, Liberia, Zambia and Morocco. FAO economic and social development paper No. 90. pp. 1-68.
- Feder, G., T. Onchan, Y. Chalamwong, and C. Honglabarom 1988. Land policies and farm productivity in Thailand. Baltimore: Johns Hopkins University Press
- Fisher, A.C. 1981. Resource and environmental economics. Cambridge Surveys of Economic Literature: Cambridge University Press N.Y., pp. 10-74.
- Fisher, A.C. and W.M. Hanemann 1986. Option value and the extinction of species. *Advances in applied micro-economics*, Vol. 4.
- Fottland, H. 1992. The Catchment Forestry Project, Morogoro Region. Memorandum. Forestry

- and Beekeeping Division, Ministry of Tourism, Natural Resources and Environment, Dar es Salaam.
- Fottland, H. 1993. Maintenance and management of natural forests in Tanzania. Contribution at Seminar for Norwegian Volunteers and Counterparts working in the Agricultural and Environmental Sector in Tanzania, Morogoro 15 - 16 October 1993. The Catchment Forestry Project, Forestry and Beekeeping Division, Ministry of Tourism, Natural Resources and Environment, Dar es Salaam (unpublished).
- Gibbon, P., K.J. Havnevik & K. Hermelle, 1993. Blighted harvest?: The World Bank and African agriculture in the 1980's. James Currey Ltd. and Africa World Press, London/Trenton pp. 1-75.
- Grainger, A. 1993. Controlling tropical deforestation. Earthscan Publication Ltd, London, 310 pp.
- Gregory, G.R. 1987. Resource economics for foresters. John Wiley and Sons, New York. 475 pp.
- Hamilton, A.C. & R. Bensted-Smith 1989. Forest conservation in East Usambara mountains. IUCN, Division of Forestry and Beekeeping, Dar es Salaam. 392 pp.
- Hamilton, A.C. & I.V. Mwashia, 1989. History of resource utilization and management under German Rule. In: Hamilton A.C. & R. Bensted-Smith (eds.) Forest conservation in the Usambara mountains. IUCN, Division of Forestry and Beekeeping, Dar es Salaam. pp. 39-40.
- Hardin, G. 1968. The tragedy of the commons. American Association for the Advancement of Science. SCIENCE 162: 1243-1248.
- Hardin, G. 1994. The tragedy of the unmanaged commons. Trends Ecol. Evol., 9:199.
- Hedberg, I. and Persson, E. (eds.), 1990. Research for conservation of the Tanzanian catchment forests. Proceedings from a workshop held in Morogoro, Tanzania, 13-17 March, 1989, Uppsala, 176 pp.
- Hermansen, J.E.; Benedict F.; Corneliusen T; Hofsten J.; and Venvik H. 1985. Catchment forestry in Tanzania, status and management. NORAD Consultancy Report 17-18. Institute of Environmental Analysis and FORINDECO, Norway.
- Hofstad, O. 1990. Tropical rainforests as non-renewable resources: the theory of optimal exploitation. In: Palo & Mery (eds.) 1990. Deforestation or development in the Third World. Vol.III. Metsäntutkimuslaitoksen tiedonantoja 349: 133-143.
- Holden, S.T. 1991. Peasants and sustainable development: the Chitemene region of Zambia - theory, evidence and models. Department of Economics and Social Sciences, AUN, Ås, Norway. 310 pp. + app.
- Holleman, F.D. 1949. Het Bantoe Grondenrecht in die Unie van Suid Afrika en omgering, Amsterdam In: Low, A. 1986. Agricultural developments in Southern Africa: Farm household economics and the food crisis. James Currey, London. pp. 108-110.
- Howell, K. 1989. The East Usambara fauna. In: A.C. Hamilton & R. Bensted-Smith (eds.). Forest conservation in the East Usambara mountains, Tanzania, IUCN, Gland, Switzerland and Cambridge, U.K., pp 351-355.
- Hughes, A.J.B. 1972. Land tenure, land rights and land communities on Swazi Nation land in Swaziland: A discussion of some inter-relationships between the traditional tenurial system and problems of agrarian development, monograph No. 7; Institute for Social Research, University of Natal, Durban.
- Hughes, A.J.B. 1974. Development in Rhodesia tribal areas: An overview, Harare: Tribal Areas

of Rhodesia Foundation.

- Iversen, S.T. 1989. Conservation of the Usambara mountains: Botanical values at the species and phytogeographical level. *Acta Universitatis Upsaliensis Symbolae Botanicae Upsalienses*, Uppsala, 28(3):218-243.
- Jackson, I.J. 1975. Relationships between rainfall parameters and interception by tropical forest. *Journal of Hydrology* 42:215-238.
- Jackson, I.J. 1989. *Climate, water and agriculture in the tropics*. Second edition, Longman Scientific and Technical, Essex, 377 pp.
- Johansson, D.R. 1978. Saintpaulias in their natural environment with notes in their present status in Tanzania and Kenya. *Biological Conservation*, 14: 45-62.
- Kaale, B. K. 1983. Tanzania five year national village afforestation plan 1982/83-1986/87. Division of Forestry and Beekeeping, Ministry of Natural Resources and Tourism, Dar es Salaam.
- Kalaghe, A. G.; T. H. Msangi & L. Johansson, 1988. Conservation of catchment forests in the Usambara mountains. *Tanzania Association of Foresters Journal* No. 6:37-47.
- Kaoneka, A.R.S. 1990. Measures to contain the problem of encroachment in natural forests. Sokoine University of Agriculture, Faculty of Forestry Record No. 43:126-130.
- Kaoneka, A.R.S. 1993. Land use in the West Usambara mountains: Analysis of ecological and socio-economic aspects with special reference to forestry. Dr. Scient. Thesis submitted to the Department of Forestry, Agricultural University of Norway. Report No. 2., 78 pp.
- Kimariyo, P.E. 1990. Silvicultural treatments to promote regeneration of commercially valuable tree species in natural forests. Sokoine University of Agriculture, Faculty of Forestry Record No. 43, pp 33-38.
- Kowal, J.M. & A.H. Kassam 1978. *Agricultural ecology of savanna*. Clarendon Press, Oxford. 403 pp.
- Leach, G. & R. Mearns. 1988. *Beyond the woodfuel crisis: People, Land, and Trees in Africa*. London Earthscan Publications. 309 pp.
- Lele, U. 1975. *The design of rural development: Lessons from Africa*. The World Bank. The Johns Hopkins University Press, Baltimore and London, 226 pp.
- Lovett, J.C. 1988a. Practical aspects of moist forest conservation in Tanzania. *Monographs in Systematic Botany, Missouri Botanical Garden*, 25:491-496.
- Lovett, J.C. 1988b. Endemism and affinities of the Tanzanian montane forest flora. *Monographs in Systematic Botany, Missouri Botanical Garden*, 25:591-598.
- Lovett, J.C. 1989. The botanical importance of the East Usambara forests in relation to other forests in Tanzania. In: A.C. Hamilton and R. Bensted-Smith (eds.), *Forest conservation in the East Usambara mountains, Tanzania, IUCN, Gland, Switzerland and Cambridge, U.K.* pp. 207-212.
- Lovett, J.C. & T. Pócs 1993. Assessment of the condition of Catchment Forest Reserves: a botanical appraisal. *Catchment Forestry Report 93.3. The Catchment Forestry Project, Forestry and Beekeeping Division, Ministry of Tourism, Natural Resources and Environment, Dar es Salaam.* 271 pp.
- Lopez, E.C. and R.J. Anderson 1983. *Natural resources and development in arid regions*. Westview Special Studies in Natural Resources and Energy Management. Westview Press Inc. 362 pp.

- Low, A. 1986. Agricultural developments in Southern Africa: Farm household economics and the food crisis. James Currey, London. 217 pp.
- Lundgren, B. 1985. Catchment forestry in Tanzania. A revised report for the joint Tanzania/Nordic Forestry Sector Review 1985. Regional soil conservation Unit/SIDA, Nairobi.
- Ministry of Agriculture, 1982. Report on the Tanzania National Agricultural Policy. Ministry of Agriculture. The United Republic of Tanzania, DSM. 197 pp.
- Mascarenhas, A. 1991. An overview of deforestation process in Tanzania. UNRISD Project: Social Dynamics of Deforestation. Institute of Resource Assessment, University of Dar es Salaam. 51 pp.
- Mather, S. 1989. Saintpaulia. In A.C. Hamilton & R. Bensted-Smith (eds.), Forest conservation in the East Usambara mountains, Tanzania, IUCN, Gland, Switzerland, and Cambridge, U.K. pp. 181-183.
- Mather, A.S. 1990. Global Forest Resources. London, Belhaven.
- Mather, P.M. 1992. Remote sensing and the detection of change. In: Whitby M.C. (ed.), Landuse change: The causes and consequences, ITE Symposium No. 27, London, HMSO, pp. 60-68.
- McKean, M. and E. Ostrom 1995. Common property regimes in the forest: Just a relic from the past? *Unasylva* 180(46):3-15.
- Mgeni, A.S.M. 1992. Farm and community forestry (village afforestation) program in Tanzania: Can it go beyond lipservice?. *AMBIO* 21(69):426-430.
- Miller, M.H. and C.W. Upton 1985. A test of the Hotelling valuation principle. *Journal of Political Economy*, No. 93, pp. 1-25.
- Minja, T.R.A. 1989. Nguru South Forest Reserve and adjacent forests: A study, Catchment Forest Project, Morogoro (unpublished).
- Mitzlaff, U.V. 1991. Managing the catchment forest reserves: Who is to be involved? A socio-economic study prepared for the Catchment Forest Project, Forest and Beekeeping Division, Dar es Salaam, Tanzania. 35 pp.+ appendices
- Mnzava, E.M. & P. Riihinen 1989. Forestry and landuse policy and administration. Tanzania Forestry Action Plan (TFAP) Sector Review Mission Report No. 9. Forestry and Beekeeping Division, Ministry of Lands, Natural Resources and Tourism. 36 pp.
- Monela, G.C. 1995a. Rainforest degradation and landuse in the Nguru mountains, Tanzania. Analysis of socio-economic and ecological aspects. Dr. Scient. Thesis. submitted at the Department of Forest Sciences, Agricultural University of Norway, Aas. Report No. 1.
- Monela, G.C. 1995b. Analysis of the use of tropical rainforest species and evaluation of buffer zones and other control mechanisms in preserving the tropical rainforest adjacent to Mhonda village in the Nguru mountains, Tanzania. Dr. Scient. Thesis submitted at the Department of Forest Sciences, Agricultural University of Norway, Aas. Report No. 2.
- Monela, G.C. 1995c. Socio-economic analysis of deforestation of tropical rainforests as a consequence of agriculture productivity, risks and population growth: a case study of Mhonda village in the Nguru mountains, Tanzania. Dr. Scient. Thesis submitted at the Department of Forest Sciences, Agricultural University of Norway, Aas. Report No. 3.
- Monela, G.C., A. O'Kting'ati and P.M. Kiwele 1993. Socio-economic aspects of charcoal consumption and environmental consequences along the Dar es Salaam-Morogoro

- highway, Tanzania. *Forest Ecology and Management*, 58:249-258.
- Munasinghe, M. 1992. Environmental Economics and valuation in development decision making. Environmental Working Paper No. 51. The World Bank Sector Policy and Research Staff, Environment Department. 77 pp.
- Munslow, B., Y. Katerere, A. Firf, and P. O'Keefe 1988. *The Fuelwood Trap. A study of the SADCC Region*. London: Earthscan Publications Ltd. and ETC Foundation. 181 pp.
- Myers, N. 1980. The present status and future prospects of tropical moist forests. *Environmental conservation* 7:101-114.
- Myers, N. 1989. *Deforestation rates in tropical forests and their climatic implications*. London, Friends of the Earth.
- Myers, N. 1994. Tropical deforestation: Rates and patterns. In: Brown K. and D.W. Pearce (eds.), *The causes of tropical deforestation*. London, UCL Press, pp. 27-40.
- MWAP, 1993. Terminal Report of the Project. Morogoro Women Afforestation Project, Morogoro, (unpublished).
- NCSSD, 1994. National Conservation Strategy for Sustainable Development. Tanzania National Environmental Management Council, Proposal. January 1994. 58 pp.
- NEAP, 1994. National Environmental Action Plan: A first Step, Tanzania. The National Environmental Policy, Division of Environment, Ministry of Tourism, Natural Resources and Environment, United Republic Of Tanzania. 43 pp.
- Newmark, W.D.(editor), 1991. *The conservation of mount Kilimanjaro*. IUCN, Gland, Switzerland, 136 pp.
- Norris, S.R.V. 1990. Using aerial photographs and GIS in quantifying deforestation of tropical rain forest: A case study from the Nguru mountains, Tanzania. Unpublished M.Sc. Dissertation in Management of Natural Resources and Sustainable Agriculture (MNRSA), NORAGRIC, Agricultural University of Norway, Ås, 120 pp.
- Nsolomo, V.R. & S.A.O. Chamshama, 1990. Human impacts on some catchment forest reserves in Morogoro region. Sokoine University of Agriculture, Faculty of Forestry record No. 43:39-45.
- O'Keefe, P. & B. Munslow. 1988. "Resolving the irresolvable: The fuelwood crisis in Africa". In: *Proceedings of the ESMAP Eastern and Southern Africa household energy planning seminar*. Washington, D.C.: World Bank, pp. 25-50.
- Ormerod, W.E. 1983. The adverse effects of economic development on agriculture and distribution of wealth in the tropics. In: Lopez, E.C. & R.J. Anderson (eds.), *Natural resources and development in arid regions*, Westview Press Inc. pp. 145-158.
- Palo, M. 1984. Deforestation scenarios for the tropics, in *Policy Analysis for Forestry Development*, Vol.II:449-463, *Proceedings of the International Conference held in Thesaloniki, Greece on August 27-31, 1984*. IUFRO, Thesaloniki.
- Palo, M. 1990. Deforestation and development in the Third World: Roles of system causality and population. In: Palo M. & G. Mery (eds.) 1990. *Deforestation or development in the Third World? Vol.III*. Division of Social Economics of Forestry, The Finnish Forestry Research Institute p. 155-173.
- Palo, M. 1993. Population and deforestation. A final proposal for a forthcoming book on: "The causes of tropical deforestation" Edited by David Pearce & Kate Brown, Published by UCL Press, London.

- Palo, M. & J. Salmi. (eds.) 1987. Deforestation or development in the Third World? Division of Social Economics of Forestry. The Finnish Forestry Research Institute, Helsinki Vol. I pp. 257.
- Palo M. & G. Mery (eds.) 1990. Deforestation or development in the Third World? Vol.III. Division of Social Economics of Forestry, The Finnish Forestry Research Institute pp. 189.
- Panayotou, T. & P.S. Ashton 1992. Not by timber alone: economics and ecology for sustaining tropical forests. Island Press, Washington D.C. 282 pp.
- Pearce, D. & R.K. Turner 1990. The economics of natural resources an the environment. London: Harvester/Wheatsheaf. 378 pp.
- Pearce, D.W. and K. Brown 1994. Saving the World tropical forests. In: Brown K. and D.W. Pearce (eds.), The causes of tropical deforestation. London, UCL Press, pp. 2-26.
- Pierce, D. 1988. The sustainable use of natural resources in developing countries. In: Turner, R.K. (ed.): Sustainable environmental management. Belhaven Press, London. p. 102-117.
- Pócs, T. 1982. The forest flora and vegetation of the old crystalline mountains of Tanzania and their importance for soil and water conservation. In: Seminar/workshop on forest conservation in Tanzania, Tanga 16-18 February, 1982, 5 pp.
- Pócs, T. 1988. The importance of catchment forests to Tanzania. Professorial Inaugural Lecture, Sokoine University of Agriculture, Morogoro, Tanzania. 11 pp.
- Pócs, T. 1990. The gene pool values and their conservation in the natural forests. Sokoine University of Agriculture, Faculty of Forestry Record No. 43 pp. 16-32.
- Pócs, T.; R.P.C. Temu; & T.R.A. Minja, 1990. Survey of the natural vegetation and flora of the Nguru mountains. In: I. Hedberg and E. Persson (editors). Research for conservation of Tanzanian catchment forests. Proceedings from a workshop held in Morogoro, Tanzania, Tanzania, 13-17 March, 1989. Uppsala, pp. 135-149.
- Polhill, R.M. 1968. Tanzania. In: conservation of vegetation in Africa south of the Sahara. Uppsala, Sweden, Acta phytogeography Suecica, 54: 166-178.
- Posner, R. 1975. Economic Analysis of Law. In Economic Foundations of Property Law, ed. B. Ackerman. Boston: Little, Brown & Co.
- Primack, R.B. 1993. Essentials of Conservation Biology. Sinauer Associates Inc., Boston University, Massachusetts, p. 78.
- Randall, A. 1987. Resource economics: an economic approach to natural resource and environmental policy. Wiley, New York. 434 pp.
- Richards, J.F. 1990. Land transformation. In: Turner B.L., W.C. Clark, R.W.Kates, J.F. Richards, J.T Mathews and W.B. Meyer (eds.), The Earth as transformed by human action. Cambridge, Cambridge University Press, pp. 163-178.
- Rodgers, W.A. and J.B. Hall 1986. Pole cutting pressure in Tanzanian forests. Forest Ecology and management, 14:133-140.
- Ruffo, C.K.; C. Mmari; S.P. Kikuwa; J. Lovett; S. Iversen & A.C. Hamilton, 1989. A preliminary list of plant species recorded from the East Usambara forests. In: A.C. Hamilton an R. Bensted-Smith (eds.), 1989. Forest conservation in the East Usambara mountains, Tanzania. IUCN, Gland, Switzerland and Cambridge, U.K., pp. 157-179.
- Runge, C.F. 1981. Common property externalities/isolation, assurance, and resource depletion in a traditional context. American Journal of Agricultural Economics 67:368-72.

- Sawe, E.N. and G. Leach 1988. In: Ahlback A.J. 1992. Why and How to mobilize all rural people of Tanzania to tree planting. A PhD Thesis submitted to the Faculty of the Graduate School of the University of Minnesota. 408 pp.
- Sayer, J. 1991. Rain forest buffer zones: Guidelines for protected area managers. IUCN, Forest Conservation Programme. 94 pp.
- Schlager, E. & E. Ostrom 1992. Property-rights regimes and natural resources: A conceptual analysis. *Land Economics* 68(3):249-62.
- Schmidt, P.R. 1989. Early exploitation and settlement in the Usambara mountains. In: A.C. Hamilton & R. Bensted-Smith (eds.), *Forest conservation in the East Usambara mountains, Tanzania*. IUCN, Gland, Switzerland and Cambridge U.K., pp. 75-78.
- Schulze, W.D. 1974. The optimal use of non-renewable resources: The theory of extraction. *Journal of Environmental Economics and Management*, No.1 pp. 53-73.
- Sharma, N.P., (ed.) 1992. *Managing the World's Forests: Looking for balance between conservation and development*. The World Bank. Kendall/Hunt Publishing Company, Iowa, 605 pp.
- Singh, K.D. 1993. The 1990 Tropical Forest Resources Assessment, *Unasylva* 44:10-19.
- Skage, T. & L.O. Næss 1994. Pitsawing and sustainable forest management. A case study of ecological and social considerations from Morogoro District, Tanzania. M.Sc. Forestry thesis, Department of Forestry, AUN. 147 pp.
- Skutsch, M.M. 1985. Forestry by the people for the people - some major problems in Tanzania's village afforestation programme. *International Tree Crops Journal* 3:2/3 p. 147-170.
- Sødal, D.P. 1988. In: Skage, T. & L.O. Næss 1994. Pitsawing and sustainable forest management. A case study of ecological and social considerations from Morogoro District, Tanzania. M.Sc. Forestry Thesis, Department of Forestry, AUN. 147 pp.
- Solow, R. 1974. "The economics of resources or the resources of economics". *American Economic Review* 64:1-14.
- Spears, J. 1988. Containing tropical deforestation: A review of priority areas for technological and policy research. Environmental Department Working Paper No. 9. Washington, D.C.: World Bank.
- Solberg, B. 1988. Choice of technology in less industrialized countries with particular reference to forestry and sawmilling. Report No. 3/1988. Department of Forest Economics, Agricultural University of Norway. 328 pp.
- Solberg, B., H.F. Hoen, A.R.S. Kaoneka, G.C. Monela and J. Valen 1994. Forest Resources and Structural Adjustment- A review of studies and literature on Tanzania and suggestions for future research priorities. Ecology and Development Paper No.10. Published by the Ecology and Development Programme, the Agricultural University of Norway, Aas, 50 pp.
- Somogyi, L. 1989. Structural disequilibrium and adjustment: the case of Tanzania. Text prepared for the seminar on "Agriculture Sector Analysis" July 1989. AICC, Arusha, Tanzania. 102 pp.
- Swanson, T. 1994. *The International Regulation of Extinction*, London, Macmillan.
- TFAP, 1989. *Tanzania Forestry Action Plan 1990/91-2007/08 and Technical Annexes, Vol. I & II*. Ministry of Lands, Natural Resources and Tourism, Dar es Salaam, Tanzania.
- Tibajuka, A. 1990. Grappling with the urban food insecurity in the midst of plenty: Government

- launches "Operation Okoa Mazao". Research Bureau and Planning Commission, Dar es Salaam. In *Tanzania Economic Trends* Volume 2 (4):13-25.
- Tibaijuka, A. 1991. Issues arising from the non-traditional export drive policy of economic adjustment in Tanzania: The case of wood and wood products in Tanzania. *Tanzania Economic Trends* 4(1):33-45.
- Todaro, M.P. 1980. *Economics for a Developing World*. Longman, Hong Kong.
- Unasylva, 1995. Common property forest resource management, Editorial. *Unasylva* 180(46):2.
- URT, 1967. Population Census, United Republic of Tanzania. Bureau of Statistics, Ministry of Finance, Dar es Salaam, 21 pp.
- URT, 1978. Population Census, United Republic of Tanzania. Bureau of Statistics, Ministry of Finance and Planning, Dar es Salaam. 29 pp.
- URT, 1988. Population Census: National profile. Bureau of Statistics, President's Office, Planning Commission, Dar es Salaam, 26 pp.
- van Ginkel, R. 1989. Plunders into Planters: Zeeland Oystermen and the Enclosure of the Marine Commons. In *Dutch Dilemmas: An anthropologist look at the Netherlands*, eds. J. Borsevain and J. Verrips, 89-105. Assen/Maastricht, The Netherlands. Van Gorcum.
- WCED, 1987. *Our Common Future*. The World Commission on Environment and Development. Oxford University Press. Oxford, New York. 400 pp.
- Westoby, J.C. 1975. Making trees serve people. *Commonwealth Forestry Review*. 54(3/4):206-215.
- White, F. 1983. *The vegetation of Africa*. UNESCO; Paris, 356 pp.
- Woods, R. 1987. Malthus, Marx and population crises. In Johnston, R.J. & Taylor, P.J. (eds.): *A world in crises? Geographical perspective*. Basil Blackwell Ltd. Oxford, U.K., p. 127-149.
- Wood, W.B. (1990). Tropical deforestation: Balancing regional development demands and global environmental concerns: *Global Environmental Change*, 1:23-41.
- World Bank, 1990. *World Development Report*. Washington D.C.
- World Bank, 1992. *Empowering villages to manage their natural resources: rural land policy in Tanzania*. A World Bank White Paper. Southern Africa Department, Agriculture Operations Division. 33 pp.
- World Bank, 1993. *World Development Report*. Washington DC.
- WRI, IUCN & UNEP 1992. *Global biodiversity strategy: guidelines for action to save, study, and use Earth's biotic wealth sustainably and equitably*. World Resources Institute (WRI), The World Conservation Union (IUCN), and United Nations Environment Programme (UNEP) in consultation with Food and Agriculture Organization (FAO), and United Nations Education, Scientific and Cultural Organization (UNESCO). 244 pp.

Personal Communications

- Chikira, H.S. 1994. Project Coordinator. Pilot Forestry Project for Community Participation Programme, CFP, Morogoro.
- Kalebi, A.K. 1994. District Catchment Forest Officer, Morogoro Region Catchment Forestry Project, Morogoro .
- Kalebi, A.K., R. Njana and T. Torstad 1994. Morogoro Region Catchment Forestry Project,

Morogoro.

Mtita, M.S. 1994. Ward Executive Secretary, Mhonda

Njana, R. 1994. Regional Catchment Forest Officer. Morogoro Region Catchment Forestry Project, Morogoro.

Torstad, T. 1994. Norwegian Volunteer and Advisor, Morogoro Catchment Forestry Project, Morogoro.

APPENDIX 1.1 SAMPLE HOUSEHOLD QUESTIONNAIRE FOR SOCIO-ECONOMIC DATA

(This questionnaire is to be completed by the head of the household)

1. Household location by altitude
 - (a) Lowland.....(b) Upland.....
2. Head of Household
 - (a) Male.....
 - (b) Female.....
3. If female give reason
 - (a) Out-migration of husband.....
 - (b) widow.....
 - (c) separation.....
 - (d) Unmarried.....
 - (e) Other.....
4. Age of farmer
 - (a) 0-15 years.....
 - (b) 16-25 years.....
 - (c) 26-65 years.....
 - (d) Above 65 years.....
5. Level of education
 - (a) Illiterate.....
 - (b) Primary school leaver.....
 - (c) Secondary school leaver.....
 - (d) Other (specify).....
6. Marital status
 - (a) Married.....# of wives).....
 - (b) Unmarried.....
 - (c) Separated.....
 - (d) Other (specify).....
7. Household composition
 - (a) Total number of people in the household.....
 - (b) Children and their ages (i) Males.....
(ii)Females.....
 - (c) Dependents and their ages (i)Males.....
(ii)Females.....
 - (d) Household members who live within.....
 - (e) Household members who live outside but remit money.....
8. Children attending school/colleges
 - (a)primary school.....
 - (b)secondary school.....
 - (c)training institute.....
 - (d)other.....

9. Household main economic activities
- (a) Farming.....
 - (b) Livestock keeping.....
 - (c) Farming and livestock keeping.....
 - (d) Employment (Specify).....
 - (e) Wood cutting in the forest.....
 - (f) Other activity.....
10. Sources of cash income for the household (T.shs./year, month or season)
- (a) Sale of crops
 - (b) Sale of domestic animals.....
 - (c) Petty/commercial business.....
 - (d) Casual employment.....
 - (e) Remittances from relatives.....
 - (f) Credit.....
 - (g) Other.....
11. Household expenditures (T.Shs./year, month, or season)
- (a) Farm inputs.....
 - (b) Food purchase.....
 - (c) Other consumer products.....
 - (d) Obligatory levies.....
 - (e) Cuts to payback subsidized farm inputs and credit.....
12. Frequency of crop sales
- (a) daily basis.....
 - (b) only when need for cash arises.....
 - (c) according to purchasing authority schedule.....
 - (d) based on availability of customer.....
 - (e) Other (specify).....
13. Location of farm holdings by altitude

Plot number	Area (ha)	Location by altitude (lowland or upland)

14. Average land slope on farm plots (low slope < 10%, high slope > 10)

Plot number	Slope of land in the farm holding (low slope <10%, high slope > 10%)

15. Location of farm in the landscape

- (a) On hill top or hillside.....
- (b) Adjacent to the forest reserve boundary.....
- (d) Beside the stream/river.....
- (e) Within the forest reserve boundary.....
- (f) Around homestead.....
- (g) Other (specify).....

16. Distance from homestead to the farm

- (a) < 2 km.....
- (b) 3-5 km.....
- (c) > 5 km.....

17. Why is your farm not around the homestead?

- (a) Lack of land near homestead.....
- (b) Is a traditional way of farming.....
- (c) Search for fertile land.....
- (d) Risk aversion (state the risk).....
- (e) Other.....

18. What is the actual size of your farm holding?.....

.....acres

19. Is farm size adequate?

- (a) Yes.....
- (b) No.....

20. If no, why has farm size not increased over the years?

- (a) Lack of land.....
- (b) Lack of inputs.....
- (c) Age and poor health.....
- (d) Natural hazards.....
- (e) Drudgery.....
- (f) Other.....

21. How much additional land do you need?

- (a) Less than 1 acre.....
- (b) 1-2 acres.....
- (c) 2-3 acres.....
- (d) More than 3 acres.....

22. How is additional land acquired in this area?
 (a) bush clearing in open land.....
 (b) Clearing forest reserve.....
 (c) Clearing grassland.....
 (d) reverting to fallow land.....
 (e) buying.....
 (f) government allocation.....
 (g) Other.....

23. Risk of soil erosion in the farm holding
 (a) High.....
 (b) Moderate.....
 (c) Low.....

24. Cropping systems

Cropping system	Short rain crops	Cropping cycle	Long rain crops	Cropping cycle
Monocropping				
Mixed cropping				
Multiple cropping				

25. Reasons for practicing mixed cropping
 (a) maximization of yield.....
 (b) maximization of labour.....
 (c) Risk aversion.....
 (d) Vermin control.....
 (e) to curb land shortage.....
 (f) Is a traditional way of farming.....
 (g) Other.....

26. In what months does the following activities take place?

Activity	Short rains	Long rains
Land clearing		
Land preparation		
Manure application		
Planting		
First weeding		
Second weeding		
Fertilizer application		
Spraying		
Harvesting		
Crop storage		
Crop selling		

27. Livestock population

Type of livestock	Number of animals	Purpose or use of animals
Cattle		
Goats		
Sheep		
Poultry		
Pigs		
Other		

28. Main source of labour for the household

- (a) Family/household labour only.....
- (b) Hired labour only.....
- (c) Both household and hired labour.....
- (d) Draught animals.....

29. Activities by gender over the year

Month	Male activities	Female activities
January		
February		
March		
April		
May		
June		
July		
August		
September		
October		
November		
December		

30. Which are the busiest months in a year?

J F M A M J J A S O N D

31. How much extra labour do you need during the busiest months?

.....

32. Explain how extra labour is obtained.....

33. What are the usual crop disposal channels?

- (a) Open market.....
- (b) Official market.....
- (c) Parallel market.....

34. If food is not enough which months in a year you face the problem?

35. How was land of your farm holding acquired?
- (a) Inheritance.....
 - (b) Bought.....
 - (c) Village offer(Government allocation).....
 - (d) Lease.....
 - (e) Clearing natural forest.....
 - (f) Other.....
36. What institutional rights do you have over your farm holding?
- (a)have title deed.....
 - (b)have property right on the land as long as I am using it.....
 - (c)village protects all my land rights against intrusion.....
 - (d)have customary rights
 - (e)No rights.....
37. Who owns household land?
- (a)Household head.....
 - (b)Spouse.....
 - (c)Both.....
 - (d)Other family members.....
38. Who decides what crops to grow (a)Husband.....(b)wife.....
- (c) both.....
39. Who decides what crops to sell.....
40. Do you use these techniques to replenish the soil in your land holding?
- (a) Fallow....
 - (b) Manure....
 - (c) Chemical fertilizer...
 - (d) Other...
 - (d) Pesticides.....ha.....kg,tins,liters/year,season
 - (e) Soil erosion control measures
 - (i) Terracing.....
 - (ii) Contour ridging....
 - (iii) Strip cropping.....
 - (iv) Other measures.....
 - (f) Agroforestry....
41. If you do not use fertilizer or manure, why?
- (a)Soil is naturally fertile.....
 - (b)Fertilizer or manure is not available.....
 - (c)Lack of money to afford the price.....
 - (d)Do not need fertilizer or manure.....
 - (e)Do not know.....
42. Land tillage and planting techniques
- (a) Ridges.....

- (b) Flat land tillage.....
 - (c) Planting in rows.....
 - (d) Planting by broadcasting.....
 - (e) Strip planting.....
43. Is your land holding in a single block?
- (i) yes..... (ii)No.....(iii)Not available.....
44. If no, how many plots do you have?.....
45. How long have you been using this farm holding?
- (a) < 1 year.....
 - (b) 1-2 years.....
 - (c) 3-4 years.....
 - (d) 4-5 years.....
 - (e) > 5 years.....
46. What are the causes of the decline in yields?
- (a) Soil erosion.....
 - (b) Lack of fertilizer and/or manure to replenish soil....
 - (c) Drought and/or Floods.....
 - (d) Poor farming techniques.....
 - (e) Poor seed variety.....
 - (f) continuous use of soil.....
 - (g) Other.....
47. Is there soil erosion problem in your farm holding or around it?
- (a) Yes.....
 - (b) No.....
48. If yes what are the causes?
- (a) Clearing of vegetation.....
 - (b) Inappropriate farming methods.....
 - (c) Other (specify).....
49. What changes in your village have you noted as a result of decreasing forest area?
50. What are the main reasons for forest disappearance?.....

51. What are the most important constraints to land use?

Type of constraint	Impact on land use		
	No impact	Some impact	Heavy impact
Lack of tools Erratic climate Lack of cash Late arrival of inputs Ill health Vermin and pest Poor seed quality Lack of production incentives Conflict among land uses Shortage of labour Insecure land tenure Population growth Declining producer prices Ecological deterioration Government interference Other (Specify)			

52. What improvements should the government make to minimize land use problems?

- (a) Reduce price of farm inputs.....
- (b) Raise producer prices.....
- (c) Reduce price of consumer prices.....
- (d) Provide credit for small farmers.....
- (e) Reduce marketing problems.....
- (f) Allow private ownership of land.....
- (g) reduce government control on agriculture.....
- (h) Other.....

53. What products are obtained from the tropical rain forest?

Forest product	Quantity (m ³ , kg/week)	Price (T.Shs./kg,m ³)
Firewood Charcoal Pitsawn timber Building poles Fruits Medicinal herbs Food supplements Other		

54. What plant species are locally used for any of the following purposes?

Purpose	Plant species used	Source of a plant	Section of plant used	Processing required
Fuelwood Food Fruit Fodder Building poles Local medicine Shade Soil erosion control Green manure Other uses (Specify)				

55. What changes in species composition are discernible in pitsawn areas in the tropical rain forest?

- (a) High reduction
- (b) moderate reduction
- (c) low reduction
- (d) No reduction

56. Do you grow trees on your farm?

- (a) Yes.....
- (b) No.....

57. If no, why?.....

-
- If yes, What species and where in the farm?
- (a) Along the farm border.....species.....
-
- (b) In specific sites within the farm....species.....
-
- (c) Intercropping trees with crops....species.....
-
- (d) Natural trees left out in the farm...species.....
-

58. For what purpose are the trees in the farm?

- (a) Indigenous tree species.....
- (b) Exotic tree species.....

59. What property rights do you have on these trees?

- (a) Can harvest them at will.....
- (b) Deserves full compensation rights for these trees.....
- (c) Can sell the land and the trees on it.....

- (d) Local community have control
- (e) No property rights.....
- 60. Natural vegetation around the holding
 - (a) Dense.....
 - (b) Medium.....
 - (c) Sparse.....
 - (d) None.....
- 61. How do you obtain forest products for your needs?
 - (i) Buy from market.....
 - (ii) Use own resource.....
 - (iii) Common wood resource.....
 - (iv) Other.....
- 62. How do you rank the position of forest products supply?

Forest product	Position of supply		
	Good	Bad	Very bad
Fuelwood			
Sawntimber			
Charcoal			
Building poles			
Fruits			
Medicinal herbs			
Food supplements			
Other			

(b) Form for firewood bundle measurements

Bundle No.	Length (cm)	Weight (kg)	Number of stems		Condition of wood (Dry/green)
			< 5 cm diameter	>5 cm diameter	

APPENDIX 1.2 SAMPLE VILLAGE QUESTIONNAIRE FOR SOCIO-ECONOMIC DATA.

This questionnaire is to be completed by village leaders including various key informants in the village who understand local customs, traditions and social and economic conditions and who can take an objective view of issues.

1. Name of village.....
2. Human population in the village
 - (a)total population.....
 - (b)actively working adults (16-60 years).....
 - (c)children (<16 years).....
 - (d)aged people (> 60 years).....
 - (e)males.....
 - (f)females.....
3. Number of households/families in the village.....
4. Male-headed households/families.....
5. Female headed households.....
6. Average size of household/family.....
7. Social services and infrastructure in the village
 - (a)schools.....(b)health care unit/dispensary.....
 - (c)shop(s).....(d)market(s).....
 - (e)cooperative society.....(f)all-weather roads.....
 - (g)electricity.....(h)pipd water.....
 - (i)flour milling machine.....
 - (j)seasonal footpaths.....
 - (k)public transport to and from the village.....
8. Sources of water for the village
 - (a)pipd from the forest reserve.....
 - (b)traditional wells/water holes.....
 - (c)rivers/streams or ponds.....
9. Adequacy of water for irrigation farming
 - (a)adequate.....(b)inadequate.....(c)other.....
10. Main activities in the village (indicate number of people taking part)
 - (a)farming.....
 - (b)animal husbandry.....
 - (d)pitsawing.....
 - (e)petty/commercial business.....
 - (f)casual employment.....
 - (g)other(specify).....
11. Estimate of average revenue/income generated from each activity per household/family
 - (a)farming.....T.shs./year
 - (b)animal husbandry....."

- (c) pitsawing..... "
 - (d) petty/commercial business "
 - (e) casual employment..... "
 - (f) other (specify)..... "
12. Main crops grown in the village (estimate total area grown by households)
- (a) maize.....ha
 - (b) beans.....ha
 - (c) vegetables.....ha
 - (d) cassava.....ha
 - (e) cocoa.....ha
 - (f) coffee.....ha
 - (g) cardamon.....ha
 - (h) fruits.....ha
 - (i) rice.....ha
 - (j) other.....ha
13. Cropping systems
- (a) monocropping.....
 - (b) mixed cropping.....
 - (c) intercropping.....
14. Land management in the village
- (a) fallow system (specify length of fallow cycle).....
 - (b) manuring.....
 - (c) chemical fertilizer application.....
 - (d) contour farming.....
 - (e) ridges across slope.....
 - (f) terracing.....
 - (g) strip cropping across slope.....
15. Energy sources for households in the village (specify proportion of households using each source)
- (a) fuelwood.....
 - (b) kerosine.....
 - (c) electricity.....
 - (d) crop residues.....
 - (e) other.....
16. Where is fuelwood obtained?
- (a) forest reserve.....
 - (b) natural forest in public land.....
 - (c) natural trees left growing in farms.....
 - (d) trees planted on farms.....
 - (e) village woodlot.....
 - (f) other
17. Fuelwood consumption for the household
- (a) number of loads.....per day or per week

(b)bags of charcoal.....per week or month

18. Type and number of livestock owned in the village

Type of livestock	Number of animals	Mode of feeding	
		Stall or zero grazing	Freelance grazing
Cattle			
Goats			
Sheep			
Pigs			
Other			

19. Perceived damage/degradation to the environment due to human activities

- (a)low.....
- (b)moderate.....
- (c)high.....
- (d)excessive.....
- (e)none.....

20. Perceived main causes of ecological damage

- (a)inappropriate farming practices.....
- (b)deforestation.....
- (c)bushfires.....
- (d)adaptation to poverty at local level.....
- (e)other.....

21. Is land shrinkage the main reason for cultivating in the buffer zones of the forest and of streams?

- (a)Yes.....
- (b)No.....

If yes, why don't you improve farming methods in your present land holding?

22. Why expansion of the farm is towards the forest reserve?

23. Why do villagers clear your land by starting fires on the borders of the forest reserve?

24. Do villagers cultivate along stream borders?.....

25. Do villagers cultivate on hills or steep terrain?

26. Do you consider the forest land as having high potential for agricultural production?

27. What are the main constraints to the following?

- (a)land.....
- (b)labour.....
- (c)Credit.....

28. What are the existing institutional land rights for the

- villagers?.....
29. What incentives are in place to prevent villagers from destroying the forest?.....
 30. What kinds of benefits are obtained from the forest?.....
 31. What incentives are in place to ensure that these benefits will continue?.....
 32. What rights do villagers have in using the forest reserve?
 33. How is the composition of plant species affected in pitsawn areas?
 34. How is the land in areas bordering the forest and streams used?
 35. What should be done in such lands to minimize intrusion into the forest reserve?.....
 36. What are the main sources of energy for the villagers?
 37. Where is fuelwood collected?.....
 38. What other taxes and dues do villagers pay?.....
 39. Does the government provide any subsidy to boost production?
 40. Do villagers get loans from credit institutions?.....
 41. What government policies have critically affected production?
 42. How do villagers perceive the environmental threat?.....
 43. What do you know of farmers demand for new technology?....
 44. Why villagers do not use credit facilities to improve their farming?.....
 45. What risks affect farmers in this area?.....
 46. What potential rewards exist for improving production?....
 47. Are villagers permitted to use trees in the periphery of the forest?.....
 48. What cultural taboos or sanctions have been used to protect particular trees or parts of the forest?.....
 49. Why do villagers expand their farms towards the forest reserve boundary?.....
 50. What is the impact of immigrants in the village on resource utilization?.....
 51. Are there any landless households in the village?.....
 52. Can the villagers sustain themselves with food supply throughout the year?.....
 53. Do villagers consider forest soils fertile for crop production?.....
 54. What kind of economic plan is used in the village?.....

- 55. For how many months in the year are the villagers self-sufficient in food?.....
- 56. What constrains people from improving farming?.....

APPENDIX 2. CALENDAR OF MAJOR EVENTS IN THE EVOLUTION OF LAND TENURE POLICIES IN TANZANIA

Source: Ministry of Lands, Housing and Urban Development, Land Division, Dar es Salaam (1993).

Annex 1: Calendar of Major Events in the Evolution of Land Tenure Policies in Tanzania.

Year	Event	Economic Implications
1874/76	Forced Villagization of rural people to village settlements of not less than 200-250 families. Operation Vijili/Sogaza now in full swing.	A landmark in the development history of the Tanzanian rural economy. It created 2 classes of peasants in the countryside: a) those who remained in their original rural settlements (vinyaji), and b) those who had to move either to join existing villages (becoming newcomers) or to start up completely new villages (vulohamuhwa). Part of the present crisis is the boiling of the potential conflict between these two groups. For, while category (a) only suffered increased land pressure (and for some) loss of land re-allocated to the new corners, category (b) was totally dispossessed, their homes (and farm buildings) were demolished and farms abandoned. In both cases no compensation was given except for promises of "free social services" which soon proved false. Given the size of the operation, the Government could not afford to deliver the promised free services to all and peasant: were called upon to be self-reliant. As the economic crisis has deepened, the Government has in fact withdrawn most of the promised social incomes by default. Since nothing was said on Land tenure, customary tenure continued to reign supreme, e.g. Village Governments allocated land to men and not women so that the marginalized groups did not benefit much from this undefined land tenure situation.
1875	Villages and Ujamaa villages act passed to "regulate" and "legalize" the conflicting and potentially explosive land tenure situation created by forced villagization. Village Councils were established to act as Village Governments and allocate land among villagers accordingly.	
1882	Local Government Act passed and the 1875 Villages Act was repealed. Villages became part and parcel of Local Government, District and Urban Councils but still nothing was said on land tenure.	
1883	The Tanzanian Agricultural Policy Act passed, among other things urging need to recognize and honour the GRO system in order to revive large scale farming and farm investments.	Would have improved the tenure situation but the policy was never implemented, and was resisted by some adamant Party officials who, despite the record, still insisted on Ujamaa and collective land ownership under Village Governments.

Year	Event	Economic Implications
1884/86	Customary tenure with its contradictions and (some potential) continuities. BUT due to economic liberalization policies, increasing awareness to civil rights, democratic participation, and the rule of law, and open criticism of past policy mistakes and injustices committed by Government, some dispossessed people both in the GRO and DLU categories in Arusha began to file legal suits to claim back their lost land rights during Operation Vijili. Some of these "win" and courts declare the present villagers and their councils as "victims", serving them with "eviction" orders.	Ethnic Category (b) villagers or entire village communities are being declared landless but at no fault of their own. The situation is politically explosive. An embarrassed Government has to protect the villagers, while saving its own face and economic interests (since it cannot afford to give due compensation to the affected individuals).
1886/87	The Government uses extraordinary procedures to under the 1873 Rural Landlord Act to extinguish all customary land titles in Mbulu and Hanang. BUT, the Courts declare the move unconstitutional, therefore null and void.	Growing confusion, land speculation and arbitrary allocations contrary to laid down procedures.
1881	Presidential Commission of Enquiry on Land Policy under Prof. Issa Shivji, distinguished law professor formed to look into the land tenure problem and give appropriate recommendations.	- ditto -
8th November, 1882	Government announces that a Bill seeking to Enfranchise Customary titled in all villages would be tabled in Parliament in December, 1882.	
12th November, 1882	Shivji submits his report to Government	
20 December, 1882	Land Tenure Act, 1882 passed	Customary tenure abolished in Operation Vijili areas.

APPENDIX 3. ORGANIZATION AND MANAGEMENT RESPONSIBILITIES OF THE FOUR REGIONAL CATCHMENT FORESTRY PROJECTS: ARUSHA, MOROGORO, KILIMANJARO AND TANGA

Source: Catchment Forestry Project, Head Office, Dar es Salaam (1993).

ORGANIZATION AND MANAGEMENT RESPONSIBILITIES OF THE FOUR REGIONAL CATCHMENT FORESTRY PROJECTS

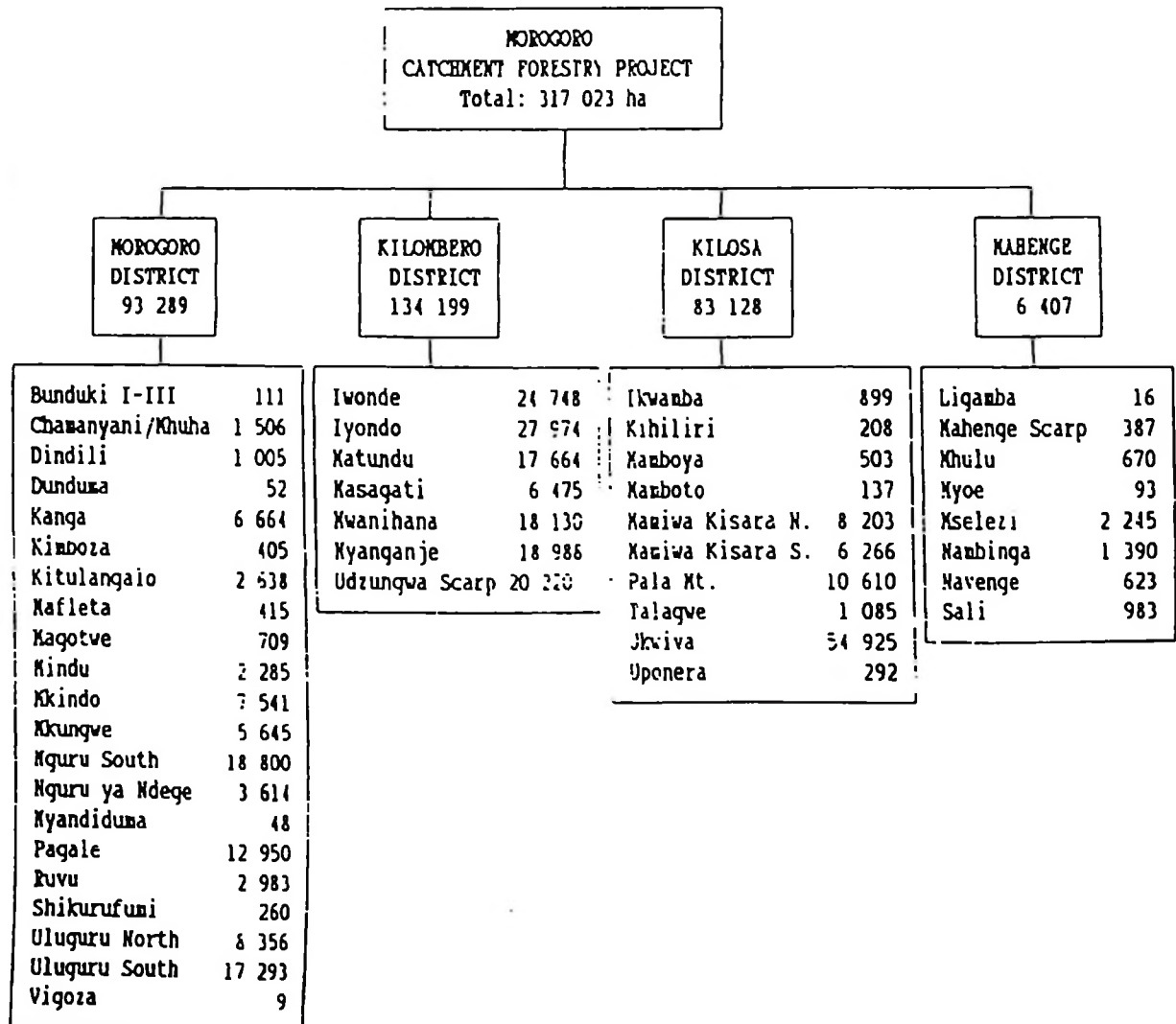
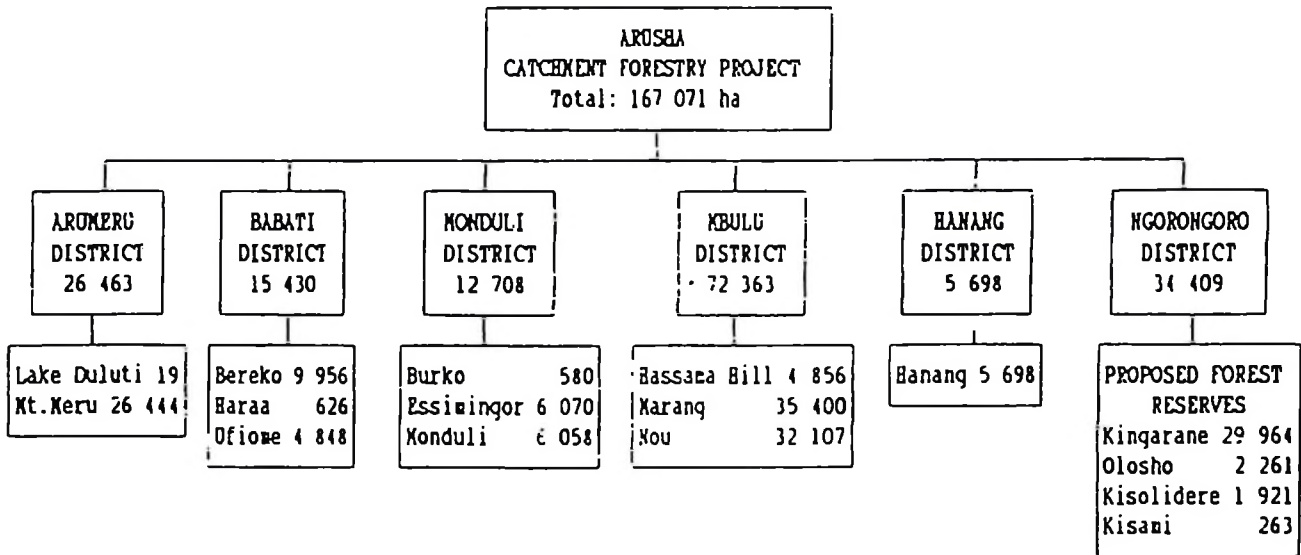

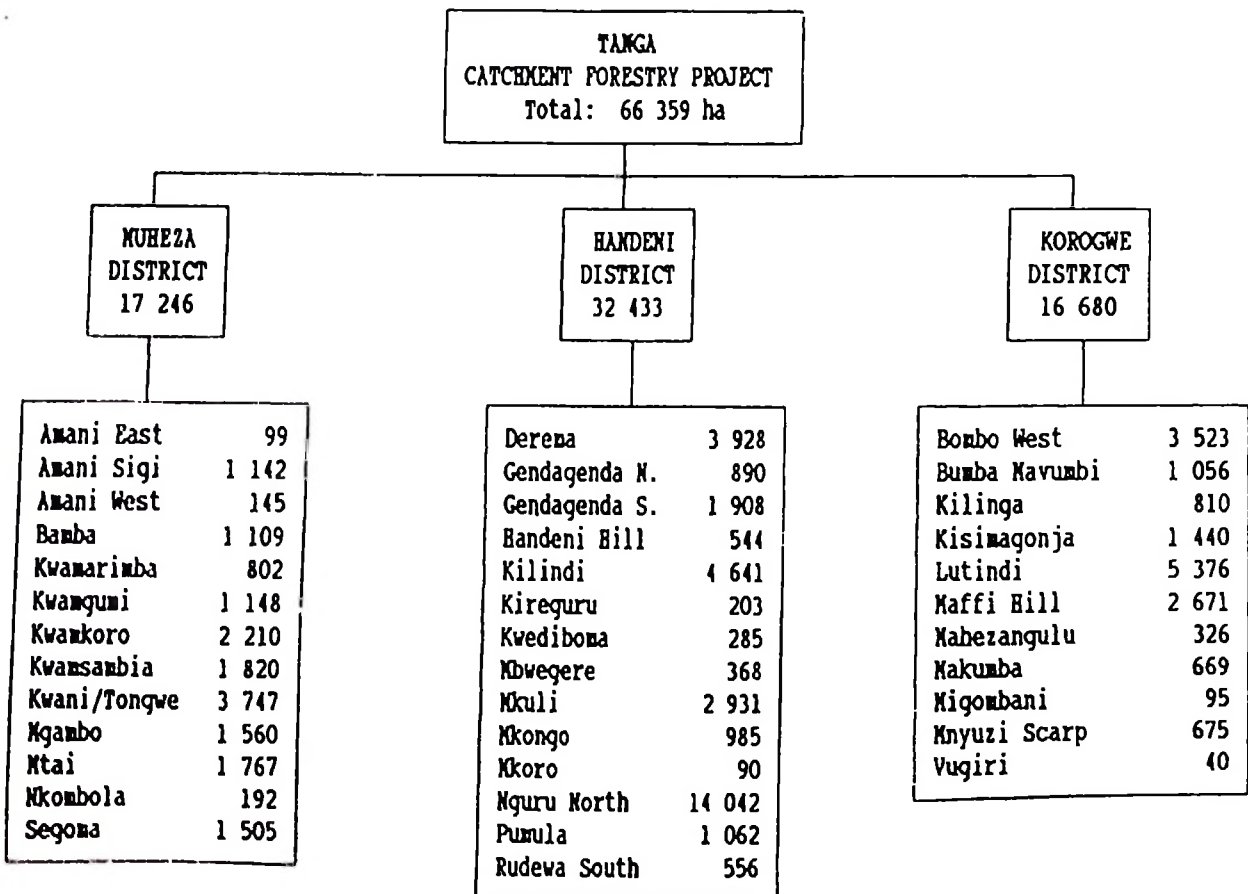
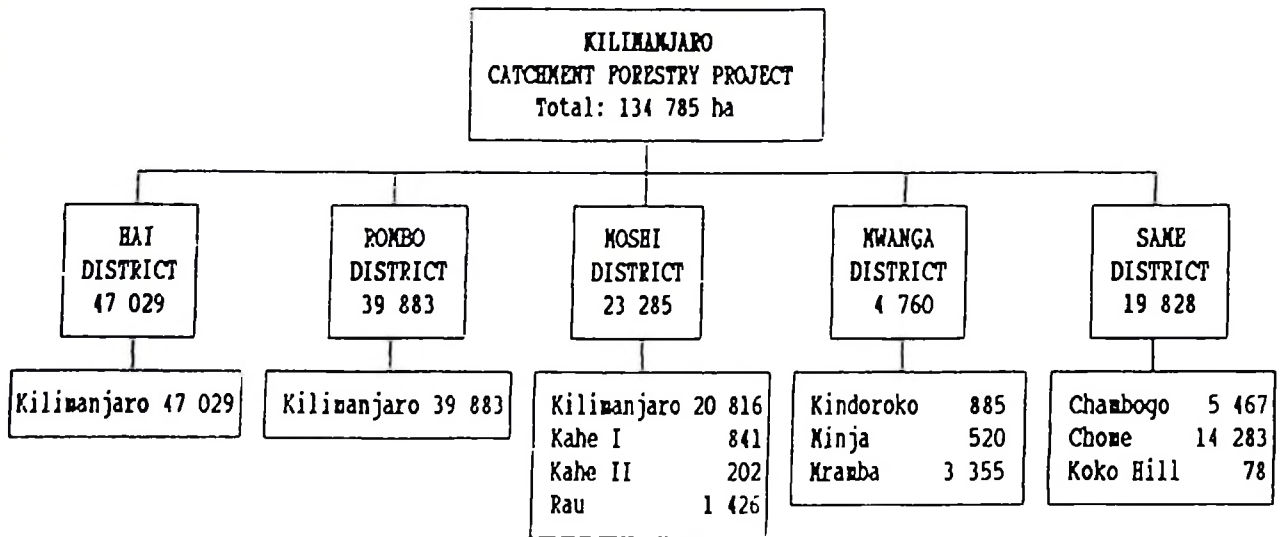

OFFICE LOCATIONS OF THE CATCHMENT FORESTRY TEAM

HEAD OFFICE

THE CATCHMENT FORESTRY OFFICE

Forest and Beekeeping Division

Ministry of Tourism, Natural Resources and Environment

Ivory Room

Box 426

Dar-es-Salaam

Telephone (051) 34845

Telex 41853 (misitu 12)

REGIONAL OFFICES

THE ARUSHA CATCHMENT FORESTRY PROJECT

Box 1257
Arusha
Telephone: 3441

THE KILIMANJARO CATCHMENT FORESTRY PROJECT

Box 1826
Moshi
Telephone: 4993

THE MOROGORO CATCHMENT FORESTRY PROJECT

Box 1020
Morogoro
Telephone: 3026

THE TANGA CATCHMENT FORESTRY PROJECT

Box 1449
Tanga
Telephone: 2684

DISTRICT OFFICES

ARUMERU DISTRICT

Box 1008
Usa River
Telephone: 5

BABATI DISTRICT

Box 400
Babati
Telephone: 11

HANANG DISTRICT

Box 1
Katesh

MBULU DISTRICT

Box 72
Mbulu
Telephone: 15

MONDULI DISTRICT

Box 43
Monduli
Telephone: 27

NGORONGORO DISTRICT

Box 12
Loliondo
Telephone: 1

HAI DISTRICT

West Kilimanjaro
Telephone: 11

MOSHI DISTRICT

Box 1826
Moshi
Telephone: 4993

MWANGA DISTRICT

Box 10
Mwanga
Telephone: 29

ROMBO DISTRICT

Mkuu
Rombo

SAME DISTRICT

Box 112
Same
Telephone: 56

MAHENGE DISTRICT

Box 29
Mahenge
Telephone: 31 32

MOROGORO DISTRICT

Box 1020
Morogoro
Telephone: 3026

KILOMBERO DISTRICT

Box 518
Ifakara
Telephone: 41

KILOSA DISTRICT

Box 82
Kilosa
Telephone: 88

HANDENI DISTRICT

Box 314
Handeni
Telephone: 11

KOROGWE DISTRICT

Box 351
Korogwe
Telephone: 2448

MUHEZA DISTRICT

Box 190
Muheza
Telephone: 25

Appendix 4. Illustration of pitsawing activities in the Nguru South Forest Reserve, Nguru mountains, Tanzania: Source: Own field data

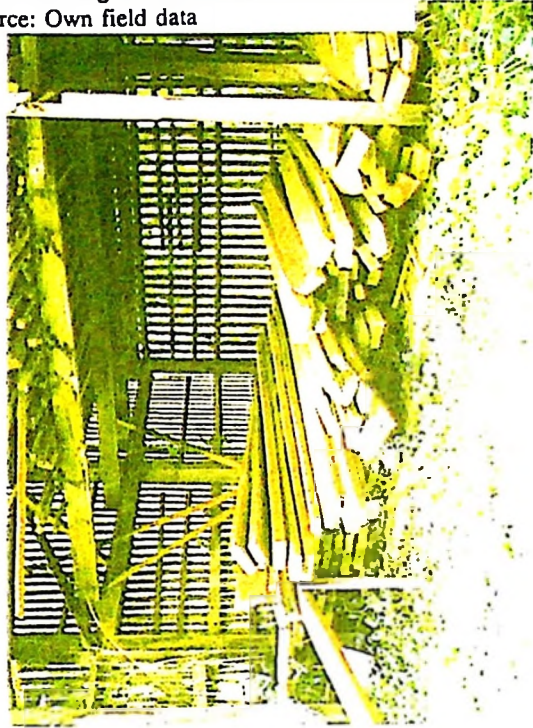

(a) and (b) Sawn timber storage sheds



(c) Manual timber transportation to the nearest roadside



(d) Pitsawyers in action.

**ANALYSIS OF THE USE OF TROPICAL RAINFOREST SPECIES AND
EVALUATION OF BUFFER ZONES AND OTHER CONTROL MECHANISMS IN
PRESERVING THE TROPICAL RAINFOREST ADJACENT TO MHONDA VILLAGE
IN THE NGURU MOUNTAINS, TANZANIA**

REPORT NUMBER 2

ABSTRACT

A study on the use of tropical rainforest species and evaluation of the role of buffer zones and other control mechanisms in the conservation of the rainforests adjacent to Mhonda village in the Nguru mountains, Morogoro was conducted in 1993/94. Data were collected using field observations and interviewing 59 farmers randomly sampled in the zone adjacent to the rainforest boundary. Questions were asked on key issues such as timber and nontimber uses of rainforest species, existing practices to control use of the rainforest, violation of forest rules, incentives to protect the rainforest and non-attractive values of the forest. Additional information was collected from relevant secondary sources such as by consultation with village, Ward, and Divisional leaders, local forest authorities and documents. Field observation involved frequent visits to the forest reserve and the buffer zone. These visits involved collection of botanical specimens, observation of vegetation changes, monitoring human impacts, assessing Forest Reserve control practices and to monitor collection from the forest and the buffer zone. A botanical inventory enumerated 72 plant families, 165 genera and 176 species of which 26 species (about 15%) are known to be endemic in the "Eastern Arc" mountains and 7 species (about 4%) are endemic in the Nguru mountains. This prevailing species richness in the rainforest is economically a valuable resource. From these species, timber and a variety of nontimber forest products for local consumption are exploited. At present some species have multiple uses and several others have potential use commercially in horticulture, breeding programmes and other economic uses. A total of 122 plant species (about 69% of enumerated species) are used locally for various purposes including social, cultural and ethical uses. Of the enumerated species, at present, 5% are exploited for timber, 41% are collected for food (i.e. vegetables, wild fruits, seed and nuts and honey), 14% for firewood, 10% for local medicine. Other uses constitute 4% of enumerated species and 31% of the enumerated species have no specific uses at present. The local value of marketable and non-marketable forest products was estimated by ethnobotanical and local market survey. The monetary value of these products in the household economy is about T.shs. 237000 and this contributes about 39% of total household consumption, valued at market prices. The survival and welfare of the people is therefore partly dependent on the rainforest. Due to depletion of forest resources in the zone peripheral to the Forest Reserve intrusion into the rainforest is high. Collection of forest products coupled with demand for new land for cultivation has led to considerable violation of forest rules particularly when it comes to fulfillment of local people's basic needs. Violation of the Forest Reserve boundary, indiscriminate cutting of trees for firewood and poles, construction of dwelling huts, setting fires and encroachment for cultivation are among the activities in the buffer zone and along the Forest Reserve boundary. This is partly encouraged by the fact that a local forester controls a forest area of about 14216 ha situated up to 20 km from his residence with about 42 km of forest boundary to patrol. Effective control of such an area is questionable under the existing transport facilities and inaccessibility of some areas located high up on the mountain slopes. In the Nguru South Forest Reserve, during the period 1989 through 1994, 29% of all pitsawing activities were carried out illegally. In 6% of the total pitsawing activities, the illegal pitsawing culprits were arrested whereas in 23% of the total pitsawing activities the illegal pitsawing culprits were not arrested. Unarrested cases account for about 79% of all illegal pitsawing. Ambiguous Forest Reserve borders, neglected role of the buffer zones, lack of forest education on the local populace, rising demand for forest products

due to growing population in an environment of poverty are other important factors enhancing forest law violation. Cultivation on river/stream banks and steep slopes prone to soil erosion is also commonly practiced with no soil conservation measures even on steep slopes. The role of buffer zones in enhancing protection of the rainforest has been neglected by the forest authorities and this needs to be revitalized. Forest law enforcement as the major means to protect the Forest Reserve seem to have had discouraging results. Forest protection based on legislative means has created disharmony with local communities leading to negative attitudes towards the protected forest. It has also enhanced the view of a forester as a "policeman", enforcing government-imposed restriction on what people perceive as their legitimate right to use the forests in their vicinity to earn a living. Since the rainforest is an essential resource for survival and sustainable development of the people in the Nguru mountains, these people must find sustainable ways to live in order to preserve the it by addressing the full range of causes of forest degradation and deforestation pressure. The strategy to achieve this is to create conditions for conservation locally by revisiting existing forest protection practices in order to adopt methods which elicit community involvement. Participatory forest management seem to be more feasible in the Nguru mountains than the use of the legal institution to resolve forest protection problems. Integrating forest management with local social and economic needs augmented with forest education in the context of the law, is essential to sustain the rainforest in the Nguru mountains. If the law is to be preserved and made effective, illegal activities must be heavily fined based on arrested volume instead of existing practice of flat rate fines.

Key words: Tropical rainforest, biodiversity, forest protection, buffer zone, forest law enforcement, community participation, plant uses, forest control mechanisms, forest reserve, sustainable management.

ACKNOWLEDGEMENT

Several individuals and institutions provided invaluable assistance to make this report a success. The Norwegian Agency for Development Cooperation (NORAD) provided financial support for this study. The Department of Forest Sciences, AUN, provided logistical support during my stay at AUN. Sokoine University of Agriculture (SUA) granted study leave for my PhD studies. The Department of Forest Economics, SUA provided logistical support during field work in Tanzania. I am very thankful to all of them.

However, I have to single out Prof. Dr. Birger Solberg of the Norwegian Forestry Research Institute (NISK) for his diligent guidance, inspiration and constructive criticism and suggestions. Messrs. A.S. Kigona, C.O.B.Z. Jamal, D. Mwaikenda, E.F. Mazengo and Mr. Kimu for conducting the interviews and field observations. Villagers, village leaders, pitsawyers, local forest staff and the Catchment Forest Project, Morogoro for responding to interviews and providing other assistance. Mr. C.K. Ruffo, Botanist at the National Tree Seed Centre, Morogoro for his invaluable assistance in identification and classification of botanical specimens. Dr. R.P.C. Temu Botanist at the Department of Forest Biology, SUA, and the SUA Herbarium (Crop Science Department), for providing assistance in the identification of plant species. Lastly, Dr. S.L.S. Maganga, Department of Forest Biology, SUA, for providing some reading material and references related to biodiversity. He also assisted in carrying some research material from Tanzania to Norway.

To all these persons and institutions, my best thanks.

TABLE OF CONTENTS

TITLE	i
ABSTRACT	ii
ACKNOWLEDGEMENT	iv
TABLE OF CONTENTS	v
LIST OF TABLES	vii
LIST OF FIGURES	vii
LIST APPENDICES	viii
LIST OF ACRONYMS	ix
METRIC UNITS	ix
1.0 INTRODUCTION	1
1.1 Background	1
1.2 Objectives of the study	1
1.3 Study outline and limitations of the study	2
1.3.1 Study outline	2
1.3.2 Limitations of the study	2
2.0 LITERATURE REVIEW RELATED TO BIODIVERSITY, BUFFER ZONES AND FOREST PROTECTION	4
2.1 Nature of biodiversity, its conservation and sustainable development	4
2.2 Economic value of biodiversity and its components: why conserve it ?	6
2.2.1 Anthropocentric or biocentric argumentation	6
2.2.2 Incentives for conserving biodiversity	13
2.2.3 Individual's criteria for biodiversity conservation	14
2.2.4 Society's criteria for biodiversity conservation	16
2.3 The biodiversity crisis: losses of biodiversity, their causes and strategies for conservation	16
2.4 Biodiversity in Tanzania	20
2.5 Rainforests and biodiversity conservation in Tanzania	21
2.6 Buffer zones for forest and biodiversity protection	22
2.7 Review of related studies in Tanzania with reference to biodiversity use, catchment forests and buffer zones	25
3.0 THE STUDY METHODOLOGY	27
3.1 The study area	27
3.2 Data collection methods and analysis	27
4.0 RESULTS AND DISCUSSIONS	30
4.1 Context of results presentation	30
4.2 Biodiversity and endemism in the Nguru mountains	30
4.2.1 Species richness in the tropical rainforest and in the adjacent zone	30
4.2.2 Endemism of species in the tropical rainforest of the Nguru mountains	31

4.2.3	Biodiversity benefits derived from the use of tropical rainforest species in the Nguru mountains	32
4.2.3.1	Present uses of the tropical rainforest species	32
4.2.3.2	Timber benefits	34
	Cost-benefit analysis of pitsawing in the Nguru mountains	34
4.2.3.3	Biodiversity benefits through collection from the rainforest	37
4.2.3.4	Potential economic benefit of the tropical rainforest biodiversity in the Nguru mountains	40
	Horticultural benefit of endemic plants	40
	Crop breeding benefit of endemic plants	40
	Other plants with potential commercial benefit	40
	Uses of tropical rainforest fauna in the Nguru mountains	41
4.2.4	Biodiversity loss and its causes in the tropical rainforest of the Nguru mountains	41
4.3	Existing practices of forest control to protect the rainforest in Nguru mountains	42
4.3.1	Personnel and logistics for forest control in the Nguru mountains	42
4.3.2	Institutional setup in the Tanzania Forest Sector and its limitations on forest protection in the Nguru mountains	44
4.3.3	Legislation and law enforcement as a means of forest control in Tanzania	45
4.3.3.1	Forest laws and regulations enforcement in the Nguru mountains	48
4.3.4	Licensing as a legislative tool for forest control in the Nguru mountains	48
	License issuing procedure and license contents	50
	License inspection procedure	51
	Effectiveness of licensing in protection of the tropical rainforest in the Nguru mountains	51
4.3.5	Royalties and forest control in the Nguru mountains	52
4.3.6	Property rights regime and forest protection in the Nguru mountains	55
4.3.7	Community participation in forest protection in the Nguru mountains	56
4.3.8	Cost-benefit approach to control illegal pitsawing in the Nguru mountains	58
4.3.9	Economic incentive for forest control in the Nguru mountains	61
4.3.10	Role of the buffer zone in forest protection in the Nguru mountains	61
	Type and extent of the buffer zone in the study area	61
	Landuse in the buffer zone	61
	Effectiveness of the buffer zone in the protection of the tropical rainforest in the Nguru mountains	63
4.3.11	New approach practiced to enforce rainforest control	64
5.0 CONCLUSIONS AND RECOMMENDATIONS		65
REFERENCES		70
APPENDICES		76

LIST OF TABLES

Table 4.1	Responses to indicate common species in the zone adjacent to the tropical rainforest	32
Table 4.2	Uses of tropical rainforest species in the Nguru mountains	33
Table 4.3	Cost of tools for pitsawing in the Nguru mountains	35
Table 4.4	Results of Cost-Benefit analysis and productivity of pitsawing in the Nguru mountains	37
Table 4.5	Forest-based income sources: percent of participating households	38
Table 4.6	Forest products harvesting and collection from the rainforest in the Nguru mountains	39
Table 4.7	Human impacts (fire and encroachment) in Forest Reserves in Morogoro District for the period 1989-1993	43
Table 4.8	Licensed and illegal pitsawing in Nguru South Forest Reserve for the period 1989-1994	50
Table 4.9	Old 1992 royalty rates for natural forest popular hardwoods and other forest products, where the produce is cut and removed by the licensee	53
Table 4.10	New royalty rates (1993) for natural forest popular hardwoods and other forest products, where the produce is cut and removed by the licensee	54
Table 4.11	Forest Reserves in the Nguru mountains	56
Table 4.12	Responses to show farmer's awareness about buffer zone functions	58
Table 4.13	Penalties imposed to apprehended illegal pitsawyers in Nguru South Forest Reserve during the period 1989-1994	60
Table 4.14	Distance of farms from the river course	62
Table 4.15	Responses to show villager's awareness on the basic rules and regulations governing the use of the Forest Reserve	63

LIST OF FIGURES

Figure 2.1	The major products which can be obtained from tropical forest trees and forests and some of their environmental and social functions	8
Figure 2.2	Categories of economic values attributed to environmental assets with examples from a tropical forest	10
Figure 2.3	An illustration of prediction in percent of tropical forest species likely to be sentenced to extinction in coming decades	17
Figure 4.1	Public forest administration in Tanzania, operating with three chains of command to manage and control the same forest resource	47
Figure 4.2	A proposed unified organogram (i.e. organizational structure) for the Tanzania Division of Forestry	49

LIST OF APPENDICES

- Appendix 1 Sample questionnaire for the household survey.
- Appendix 2 Species composition of the tropical rainforest as enumerated in the botanical inventory
- Appendix 3 List of plants commonly used locally in the Nguru mountains
- Appendix 4 Species in the zone adjacent to the tropical rainforest
- Appendix 5 Main tree species enumerated along river/stream banks
- Appendix 6 Species endemic and near-endemic in the tropical rainforest of the Nguru mountains
- Appendix 7A The definition of hardwood timber classes as presented in the Forest Ordinance, The Forest (Amendment Rules) 1992. Government Notice No. 251.
- Appendix 7B The definition of hardwood timber classes as presented in the Forest Ordinance, The Forest (Amendment Rules) 1993. Government Notice No. 265.
- Appendix 8. Range of uses recorded for various species in the Nguru mountains
- Appendix 9. List of Reserved Trees in Tanzania.

LIST OF ACRONYMS

AUN	Agricultural University of Norway
CAP	Chapter in the Tanzania Statute (Law) Book
CFP	Catchment Forestry Project
FAO	Food and Agriculture Organization
GDP	Gross Domestic Product
IDA	International Development Agency
IUCN	International Union for Conservation of Nature
ITTO	International Tropical Timber Organization
MLNRT	Ministry of Lands, Natural Resources and Tourism
MNRSA	Management of Natural Resources and Sustainable Agriculture
MTNRE	Ministry of Tourism, Natural Resources and Environment
NORAGRIC	Norwegian Centre for International Agricultural Development
PMO	Prime Minister's Office
SIDA	Swedish International Development Agency
SUB	Sustainable Use of Biodiversity
TEV	Total Economic Value
TFAP	Tanzania Forestry Action Plan
T.Shs.	Tanzania Shillings
TWICO	Tanzania Wood Industries Corporation
UNEP	United Nations Environment Programme
UNESCO	United Nations Educational, Scientific and Cultural Organization
US	United States
WCED	World Commission on Environment and Development
WRI	World Resources Institute

METRIC UNITS

mm	millimetre
cm	centimetre
m	metre
km	kilometre
ha	hectare
g	gramme
kg	kilogramme
t	metric tonne

Exchange rate

1 USD = T.Shs. 520 (as at mid-1994).

1.0 INTRODUCTION

1.1 Background

Tropical forests are without doubt one of the most important ecosystems from the point of view of global biodiversity (WCED 1987, Sharma 1992). However, the threat to this valuable forest ecosystem is severe and widespread such that the action needed to protect this forest type is correspondingly urgent, broad in scope and requiring substantial long-term commitments. This in turn means that there is a need for finding various means which can be used to minimize the threat (Sayer 1991). Community participation has been used in other places in recent times as a means for reducing the intensity of forest destruction (Ahlback 1992). This is a result of research findings in various places which have led to the conclusion that forest resource misuse or overuse at any time cannot be solved by increased use of force in policing the forest resources (Sayer 1991). The strategy to involve people in forest management (participatory forest management) seems to have potential for wide application in contemporary times. Its effectiveness requires that people must understand, accept and participate fully in the solutions reached in resolving forest management problems in their area (Mitzlaff 1991).

The same can be said when arranging control patrols around the forest areas. It is only through involving villagers in such patrols that illegal forest harvesters can be identified and solutions against them can be taken (Ahlback 1992). Patrols and law enforcement have customarily been used to minimize the intensity of forest destruction (TFAP 1989, NEAP 1994). The results have been discouraging in most places as can be attested by the relentless high rate of forest and woodland degradation leading to deforestation. Application of extension education has also been used to help to resolve the crisis. Under the method, villagers are educated on the impacts of forest destruction to the soil and biological diversity. Since this requires widespread intensive extension work to cover different disciplines it has been curtailed by lack of resources and commitment in most cases.

Land use planning has also been among the sensitive issues considered when planning to minimize forest destruction. This has been pursued in the context that land under several management regimes or systems can be a way to sustainable utilization of this land as well as biological diversity which dwells in such a land (Brandon & Wells 1992). Buffer zones and buffer zone management provide another practical means for protection of tropical forests and biodiversity (Sayer 1991). The buffer zones function mainly to provide extra protection against storm damage, drought erosion and other forms of forest damage. It extends the habitat and the population size of large wide ranging species in the protected area. It also provides barrier against human access and illegal use of the strictly protected core zone (*ibid*).

1.2 Objectives of the study

The tropical rainforest in the Nguru mountains is an important ecosystem from the ecological and economic points of view but is threatened by human impacts. The broad objective of this study is to empirically analyze the use of rainforest species and to evaluate the role of buffer zones and

other control mechanisms in preserving the rainforest adjacent to Mhonda village in the nguru mountains.

The more specific objectives are:

- (i) To assess the use and benefit of the rainforest species by the local communities.
- (ii) To assess plant species richness of the rainforest with regard to biodiversity importance.
- (iii) To assess human impacts on species richness inside and on the periphery of the rainforest.
- (iv) To evaluate the types of control mechanisms practiced to protect the rainforest.
- (v) To evaluate the role of buffer zones in rainforest control.
- (vi) To recommend steps necessary for improving protection of the rainforest.

1.3 Study outline and main limitations

1.3.1 Study outline

This report is divided into 5 chapters to address the use of rainforest species and various mechanisms to protect the rainforest in the Nguru mountains. Review of literature and previous studies as a theoretical basis for the study is presented in Chapter 2. The theoretical aspects reviewed are those related to rainforest biodiversity, buffer zones and other forest control methods for sustainable forest management. Considerable effort and time was devoted for relevant literature review as a necessary background for the study. Chapter 3 describes the study methodology with main focus on the study area description, methods of data collection and data analysis. The study methodology is based on interviews and field observations. No earlier studies have been carried out in the Nguru mountains to assess the use of rainforest plant species and forest control practices in the area. The survey and analysis carried out in this study is a contribution to the body of knowledge on rainforest species richness, the uses and value of rainforest species, and protection measures for the rainforest. Chapter 4 presents study results and discussions. These are presented in the context of economic benefit and uses of rainforest species, and existing forest control measures currently practiced to protect the rainforest and its biodiversity. The list of species enumerated in the tropical rainforest is presented to portray species richness of the rainforest as an important dimension of biodiversity with direct impact on possible uses and economic benefit of plants. Chapter 5 presents the general conclusions and recommendations from the study. It also includes some possible future research topics related to this study. Finally Appendices are presented.

1.3.2 Limitations of the study

The study has the following limitations which need to be taken into account when interpreting the results:

- (i) Villager's responses to the interviews and questionnaire relied on memory since they keep no records of their activities.
- (ii) Species enumeration was not based on permanent sample plots but on sampling along the transect walks across the rainforest and visits to various vegetation types in the rainforest.
- (iii) There was a notable difficulty on the part of respondents to give correct account of household's consumption of forest products. Also conversion of units was a problem since

some farmers use local units which are not standardized. Moreover collection of some forest products was not regular.

- (iv) The ethnobotanical approach relied on villager's estimates of various forest products or sustainable levels of extraction and these estimates were not always verified by empirical measurements or not measured by scientific standards.
- (v) In some cases interviewers could have misunderstood villager's responses while interviewees and village guides could have misinterpreted the questions.
- (vi) Estimates by collectors may be biased due to local influences or incorrect assumptions regarding level of experience, ecological process or their relationship with the researcher.

2.0 LITERATURE REVIEW RELATED TO BIODIVERSITY, BUFFER ZONES AND FOREST PROTECTION

2.1 Nature of biodiversity, its conservation and sustainable development

Biodiversity is the totality of genes, species and ecosystems in a region (WRI, IUCN & UNEP 1992). Biodiversity, also referred to as biological diversity is the total variety of life on earth (Ryan 1992). It also refers to the full variety of life in an area (Thomas & Straley 1993). It is a product of hundreds of millions of years of evolutionary history. The domestication and breeding of local varieties of crops and livestock have further shaped biodiversity over time. It is thus a fragile resource that must be managed conservatively (Sharma 1992). According to Thomas and Straley (1993), biodiversity in its totality can be divided into three hierarchical categories that describe quite different aspects of living systems that scientists measure in different ways. These are genes, species and ecosystem. Species diversity is the number and relative abundance of different species of plants, animals, fungi, bacteria, and protozoa present in a region. genetic diversity is the genetic variation among individuals of the species. Ecosystem diversity is the variety of different ecosystems present. Nonetheless, there are other expressions of biodiversity that can be important. These include: relative abundance of species, the age structure of populations, the pattern of communities in a region, changes in community composition and structure over time and even such ecological processes such as predation, parasitism and mutualism. These are often important to examine to meet specific management or policy goals. Humanity depends totally on this community of life - the biosphere - of which humans are an integral part (WRI, IUCN & UNEP 1992). Hence the reason for international concern to conserve biodiversity following signals that it is threatened in many parts of the world (WCED 1987).

Formerly, conservation of biological diversity was perceived as the protection from any use. Today, on the contrary, it is perceived as a means to ensure future capacity for use (Thomas & Straley 1993). The World Resources Institute define conservation of biological diversity as the management of human interactions with the variety of life forms and ecosystems so as to maximize the benefits they provide today and maintain the potential to meet future generation's needs and aspirations. This definition ascribes to the concept of sustainable development which the WCED (1987) defines as " development that meets the needs of the present without compromising the ability of the future generations to meet their needs". Thus sustainable development in this sense hinges on two key concepts: the concept of needs particularly for the poor who should be given overriding priority and the concept of limitations imposed by technology and social organizations on the environments ability to meet present and future needs. Consequently development has to be both people-centered and conservation-based. Earth's plants, animals and microorganisms interacting with one another and with the physical environment in ecosystems - form the foundation of sustainable development (WRI, IUCN & UNEP 1992).

Biotic resources from this wealth of life support human livelihoods and aspirations and make it possible to adapt to changing needs and environments. The steady erosion of the diversity of

genes, species, and ecosystems taking place today will undermine progress toward a sustainable society. In other words, unless we protect the structure functions and diversity of the world's natural systems - on which our species and all others depend - development will undermine itself and fail. Indeed the continuing loss of biodiversity is a telling measure of the imbalance between human needs and wants and nature's capacity. Unless we use the earth's resources sustainably and prudently, we deny people their future. Development must not come at the expense of other groups or later generations, nor threaten other species' survival. Thus the conservation of biodiversity is fundamental to the success of the development process. As the Global Biodiversity Strategy explains, conserving biodiversity is not just a matter of protecting wildlife in nature reserves. It is also about safeguarding the natural systems of the earth, these are our life support-systems; purifying the waterways; recycling oxygen, carbon and other essential elements; maintaining the fertility of the soil; providing food from the land, freshwater, and seas; yielding medicines; and safeguarding the genetic richness on which we depend in the ceaseless struggle to improve our crops and livestock.

In 1980, tropical forests covered 11.6 million km² (Sayer 1991). Data from the World Conservation Monitoring Centre indicate that at that time about 4% of them were located in national parks or nature reserves. FAO (1988) suggest that at least 10% of these forests were lost in the decade from 1980 to 1990. During this period, however, many new parks and reserves were established in the tropics and protected areas now cover at least 6% of the tropical forest biome (Sayer 1991). New protected area are still being established in Amazonia and in the Zaire-Congo tropical forest block (*ibid.*). But in many parts of the tropics, the human pressure on land is so great that options for establishing new parks and reserves are rapidly disappearing. In Madagascar, West Africa and the Atlantic coastal area of Brazil the forests are already reduced to small isolated fragments, scattered through landscapes which are predominantly agricultural (*ibid.*). These small island parks and reserves will not be enough to conserve all the values of tropical forests. In particular, large wide-ranging animals, and those tree species that exist at very low densities, will be very much at risk in small protected areas. Similarly, if dense human settlements exist close to the boundaries of the protected areas, there will inevitably be problems of agricultural encroachment, poaching and illegal harvesting of wood and other forest products. Experience has shown that, in these situations legal protection is rarely sufficient to guarantee the continuing integrity of conservation areas. In this sense the major objective of development becomes satisfaction of human needs and aspirations.

The WCED (1987) identifies global human population growth as one important threat to biodiversity conservation because there has been a direct correlation in biodiversity destruction as population increases. In the remote past, human actions were trivial when set against the dominant processes of nature. That is no longer the case. The human species now influences the fundamental processes of nature. Ozone depletion, worldwide pollution, and climatic changes are testimonies to human power. The human race had 850 million people when it entered the industrial age, sharing earth with life forms nearly as diverse as the earth has ever possessed. Today, with population nearly six times as large and resource consumption proportionately far greater, both the limits of nature and the price of overstepping them are becoming clear (WRI, IUCN & UNEP 1992). A turning point is upon human beings as they can continue to simplify

the environment to meet immediate needs, at the cost of long-term benefits, or they can conserve life's precious diversity and use it sustainably. This implies humans current management of resources will determine the kind of world we deliver to the next generations. It could be a world rich in possibilities or one impoverished of life. However, social and economic development will succeed only if humans do the first (*ibid.*).

Economic development is essential if millions of people who live in poverty and endure hunger and hopelessness are to achieve a quality of life commensurate with the most basic human rights. Economic progress is urgent to meet the needs of today and to give hope to the tomorrow's generations. Better health care, education, employment and other opportunities for a creative life are also essential components of a strategy for keeping human population within the earth's carrying capacity (WCED 1987; WRI, IUCN & UNEP 1992). FAO report, during the World Food Day, October 1993, showed that world forest resources were destroyed at an annual rate of 15.4 million hectares between 1980-1990 and by 2025 the destruction is expected to double the 1980-1990 report figure. During such destruction of natural forest, besides plants, the animals, birds, insects and other micro species living in the forest disappear as well. The Global Biodiversity Strategy (WRI, IUCN & UNEP 1992) estimates show that about 100 species are lost per day in the closed tropical rain forest, many of these species have yet been discovered and they are beneficial to the society and ecological issues as a whole. Therefore conservation of biodiversity is a crucial issue locally and internationally. Globally, efforts have started.

Recent years have seen many major reviews of the world situation and human needs. In the 1980s the "World Conservation Strategy" drew attention to the inseparable link between conservation and development and emphasized the need for sustainability. The World Commission on Environment and Development (WCED 1987) brought this necessity home to a worldwide audience, whose governments examined the need for action in their environment perspective to the year 2000 and beyond. Biennial world resources and environmental data reports and annual UNEP State of the Environment reports have provided authoritative - and often disturbing - overviews of the state of the earth. The successor and complement to the World Conservation Strategy; entitled *Caring for the Earth: A Strategy for Sustainable Living* once more emphasized the need for the world community to change policies; reduce excessive consumption; conserve the life of the planet, and live within the earth's carrying capacity. The Global Biodiversity Strategy, UNEP Convention on Biological Diversity and the Rio Earth Summit on Environment all emphasize on conservation of biodiversity. During development of these major reports and reviews, it has become evident that rhetoric in reports and conventions is useful only if it leads to action- more action and better action than would have been taken otherwise (WRI, IUCN & UNEP 1992). Locally National Environmental Action Plans provide the forum for biological conservation strategies and actions in line with global perspectives.

2.2 Economic value of biodiversity and its components: why conserve it ?

2.2.1 Anthropocentric or biocentric argumentation

In most cases, biodiversity is evaluated on the basis of human interests i.e. anthropocentric or

egoistical argumentation (Hågvar 1994). However, Næss (1986) developed a biocentric philosophy which is in support of the intrinsic value of all species. This is based on respect for the inherent value of both human and nonhuman life. Taylor (1986) supports this view by considering man as a member of the earth's community as other living things. Thus Ehrenfeld (1988) and Randall (1991) point to the danger of relying too heavily on the anthropocentric motives because if technologies are developed to the level of substituting for naturally-occurring genetic material, we may leave biodiversity unprotected. Thus it would be safer to argue for the intrinsic value of all life forms, making us independent of changing practical evaluations of biodiversity.

The WCED (1987) on its concern for biodiversity preservation relies heavily on strong anthropocentric arguments especially economical, although scientific, cultural, aesthetical and ethical were also considered as important. Wilson (1988) presents an unsystematic multitude of arguments for preserving biodiversity. Hågvar (1994) divides his argument into three main categories: (i) ecological, describing the need of biodiversity to support basic functions of nature (ii) egoistical, or utilitarian, which look to nature as a means of fulfilling human needs and wishes (including recreational and aesthetical values) (iii) ethical, encompassing the inherent value of all life forms, and human responsibility for future generations and future evolution. The purely ecological arguments are valid even in the absence of man, but also favour man because man rely upon the basic functions in nature for his survival. Based on both the anthropocentric and biocentric philosophies the major products which can be obtained from tropical trees and forests and some of their environmental and social functions are partly summarized in Figure 2.1. In general, the scientific community consider the conservation of biodiversity as essential to the health and productivity of the environment (Thomas & Straley 1993).

The sheer variety of life has a great value both use value and nonuse value (Randall 1993). The economic value of environmental assets including the variety of life forms like those found in the tropical rainforest, can be broken down into a set of component parts (Pearce 1993). Conceptually, the Total Economic Value (TEV) of a resource comprises of its use value (UV) and non-use value (NUV) (Munasinghe 1993, Pearce 1993). Use values may be broken down further into direct use value (DUV) and indirect use value (IUV) whereas nonuse value comprise of existence value (EV) and option value (OV) (*ibid.*). In mathematical expression:

$$TEV = UV + NUV$$

$$\text{or } TEV = [DUV + IUV + OV] + [NUV]$$

The disaggregation of TEV in schematic form is presented in Figure 2.2 which presents categories of economic values attributed to environmental assets with examples from the tropical rainforest which is the main focus of this study. According to Munasinghe (1993), direct use value is determined by the contribution an environmental asset makes to current production or consumption. Some direct use values have traditionally been easy to measure as gross value of the total quantity of biological production that can be harvested and utilized (Navrud 1993). The use of rainforest plants assessed in this study is a direct use value. Indirect use value includes the benefits derived basically from functional services that the environment provides to support current production and consumption, for example the ecological functions like natural filtration of polluted water or recycling of nutrients (Munasinghe 1993).

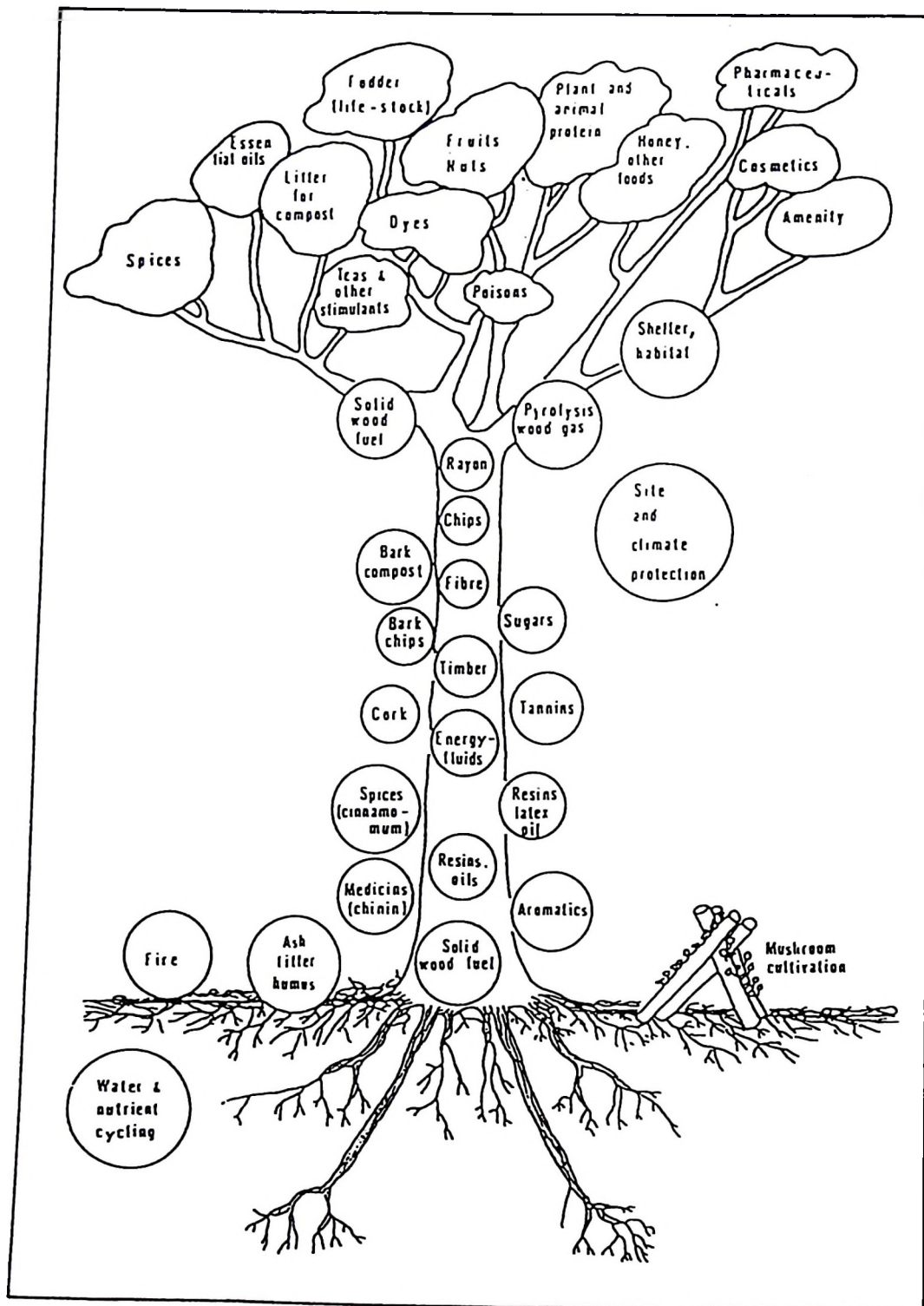

Figure 2.1. The major products which can be obtained from tropical trees and forests and some of their environmental and social functions. Source: Furtado *et al.* (1990), p. 69.

Indirect use values and some direct use values are difficult to measure. Ecological functions which are indirect use values are difficult to measure and so are nontimber forest products such as nuts, rattan and latex, which are direct use values that need market and survey data to measure them (Tewari 1994, Tilling 1994). The direct use value of medicinal plants for the world at large is even more difficult to measure (Pearce 1993, Tewari 1994).

The importance of the nonuse values has gained empirical evidence in recent years although there are still fundamental methodological problems in translating such values into figures (Navrud 1993, Veisten *et al.* 1993). These are mainly existence value, bequest value and option value (Pearce and Moran 1994). According to Pearce (1993) and Munasinghe (1993), Option values relate to the amount that individuals would be willing to pay to conserve a resource for future use (i.e. potential use value). It is basically the premium that consumers are willing to pay for an unutilized asset, simply to avoid the risk of not having it available in the future. On the other hand, Existence value relates to valuations of the environmental asset unrelated to either current or optional use, deriving simply from its existence (Pearce 1993). Existence value arises from the satisfaction of merely knowing that the asset exists, although the valuer has no intentions of using it (Munasinghe 1993). Bequest value measures the benefit accruing to any individual from the knowledge that others might benefit from a resource in future (Pearce & Moran 1994). Using non-market valuation methods, it is essential to bring nonuse values into economic calculations in order to improve the allocation of resources (Veisten *et al.* 1993). Non-market valuation methods such as the Contingent Valuation Method, Travel Cost Method and Willingness to Pay technique, are outside the scope of this study hence an interested reader may refer to other relevant literature.

According to Pearce, Markandya and Barbier (1992), Economic Theory clearly defines Total User Value (TUV) as follows:

Total User Value = Actual Use Value + Option Value.

In this context of Total User Value, Total Economic Value can be expressed as follows:

Total Economic Value = Actual Use Value + Option Value + Existence Value.

Since Option values and Existence values can originate from similar sources, there tends to be considerable overlap and ambiguity in the breakdown categories, especially with regard to nonuse values. Therefore, these categories are useful mainly as an indicative guide. The distinctions often become irrelevant in practical estimation since the objective is to measure TUV rather than its components (Munasinghe 1993). Nonuse values are linked to altruistic motives and the differing forms of altruism include intergenerational altruism or the bequest motive, interpersonal altruism or the gift motive, stewardship (originating more from ethical than utilitarian motives), and q-Altruism which states that the resource has an intrinsic right to exist. Since the q-Altruism incorporates the notion that the welfare function should be derived from something more than purely human utility, it falls outside the conventional economic theory (*ibid.*).

The variety of distinctive species, ecosystems and habitats such as those in the tropical rainforest influence the productivity and services provided by ecosystems (WRI, IUCN & UNEP 1992). Such ecosystems provide us with services such as climate moderation, water and air filtration. They also provide soil and nutrient conservation, and pest control.

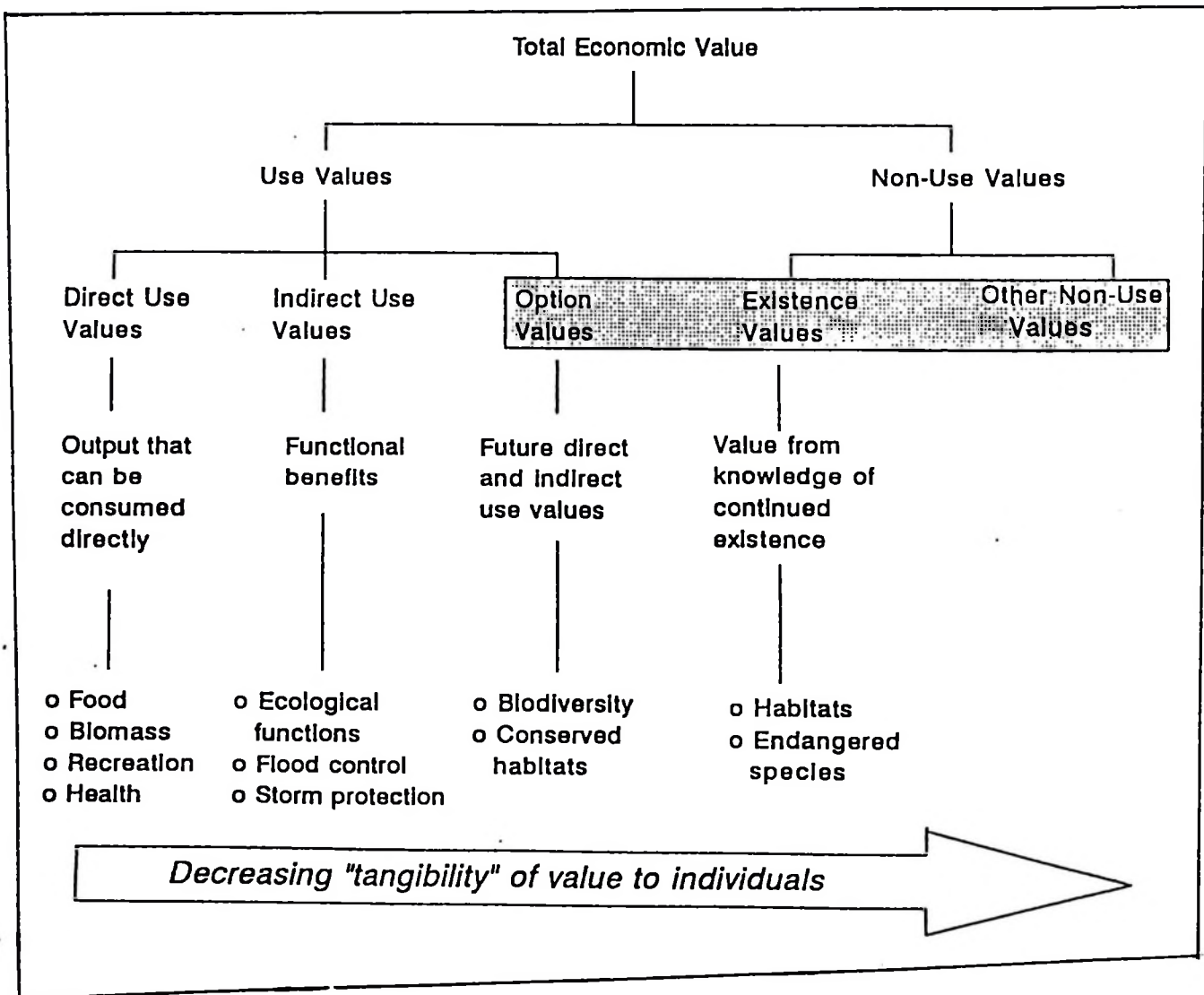

Figure 2.2. Categories of economic values attributed to environmental assets with examples from a tropical forest. Source: Adapted from Munasinghe (1993) p. 22.

The species are used as food, building materials, energy and as medicines. As a variety of species in an ecosystem change - a legacy of extinction or species introduction - the ecosystem's ability to absorb pollution, maintain soil fertility and microclimate, cleanse water, and provide other invaluable services changes too. For example when the elephant - a voracious vegetarian - disappeared from large areas of its traditional range in Africa, the ecosystem was altered as grasslands reverted to woodlands and woodland wildlife returned (*ibid.*). The value of variety is particularly apparent in agriculture and forestry to breed higher yielding species and disease resistant plants and animal varieties to stabilize and enhance productivity. The wisdom of these techniques is being reaffirmed today as farmers around the world turn to alternative low-input production systems. The genetic diversity found within individual crops is also of tremendous value. Genetic diversity provides an edge in the constant evolutionary battle between crops and livestock and the pests and diseases that prey on them. In age-old systems, several genetically distinct varieties of crops are planted together as a hedge against crop failure. Breeders and farmers also draw on the genetic diversity of crops and livestock to increase yields and respond to changing environmental conditions.

The opportunities provided by genetic engineering - which allows the transfer of genes among species - will further increase the opportunities genetic diversity provides for enhancing agricultural productivity. From both wild and domesticated components of biodiversity, humans derives all of its food and many medicines and industrial products. Economic benefits from wild species alone make up an estimated 4.5 percent of the GDP of the United States in the 1970s (WRI, IUCN & UNEP 1992). Fisheries, largely based on wild species, contributed about 100 million tons of food worldwide in 1989 (*ibid.*). Indeed wild species are dietary mainstays in much of the world. Timber, ornamental plants, oils, gums, and many fibres also come from the wild. In Africa, all forest reserves, wild animals, land and other living creatures are typically considered state properties and hence when tourists pay a visit or timber traders buy timber, the government benefit much from what they pay, be in local or foreign currency (Sharma 1992). Wild biotic resources also serve recreation and tourism. For many people, simply knowing that a particular species or ecosystem exists is inspiring or comforting (i.e. existence and option value).

The components of biodiversity are also important to human health. Once, nearly all medicines came from plants and animals, and even today they remain vital. Traditional medicines forms the basis of primary health care for about 80% of people living in Developing Countries, more than 3 billion people in all (WRI, IUCN & UNEP 1992). For example more than 5100 species are used in Chinese traditional medicine alone and people in North-Western Amazonia have tapped some 2000 species. The World Health Organization is encouraging its use including in industrialized countries where its use is expanding rapidly. As for modern pharmaceutical, one-fourth of all prescriptions dispensed in the US contain active ingredients extracted from plants and over 3000 antibiotics - including penicillin and tetracycline - are derived from microorganisms. Cyclosporin developed from a soil fungus, revolutionalized heart and kidney transplant surgery by suppressing the immune reaction. Aspirin and many other drugs that are now synthesized were first discovered in the wild (*ibid.*).

Over time, the greatest value of the variety of life may be found in the opportunities it provides humanity for adapting to local and global change. The unknown potential of genes, species and ecosystems represents a huge biological frontier of inestimable but certainly high value. Genetic diversity will enable breeders to tailor crops to new climatic conditions. Earth's biota hold the still-secret cures for emerging diseases. A diverse array of genes, species and ecosystems is a resource that can be tapped as human needs and demands change. Because biodiversity is so closely intertwined with human needs, its conservation should rightfully be considered an element of national security. Biodiversity is also closely linked to cultural diversity. Attitudes toward biodiversity and the respect that people show for other species are strongly influenced by moral, cultural and religious values. Human cultures are shaped in part by living environment that they in turn influence - and this linkage has profoundly helped determine cultural values. Most of the world's religions teach respect for the diversity of life and concern for its conservation.

Indeed, the variety of life is the backdrop against which culture itself languishes or flourishes. Even so, some reduction in biodiversity has been an inevitable consequences of human development, as species-rich forests and wetlands have been converted to relatively species-poor farmlands and plantations. Such conversions are themselves an aspect of the use and management of biodiversity, and there can be no doubt that they are beneficial. But many ecosystems have been converted to impoverished systems that are less productive - economically as well as biologically. Such misuse not only disrupts ecosystem function, it also imposes a cost. Sometimes we ask ourselves why should disappearing biodiversity (plants, birds, beetles etc.) be of concern to us ? To biologists and to many others the question hardly needs asking. In the actual fact a species is a unique and irreplaceable product of millions of years of evolution, a thing of value for scientific study, for its beauty and for itself (Sharma 1992). For many people, however, a more compelling reason to conserve biodiversity is likely to be pure self-interest, like every species, occurrence is intimately dependent on others for its well-being (*ibid.*). Time after time, creatures thought useless or harmful are now found to play crucial roles in natural systems as described above. For example, predators driven to extinction, no longer keep populations of rodents or insects in check. Also earthworms or termites killed by pesticides no longer aerate soils. Mangrove cut for firewood and poles no longer protect coastline from erosion. Thus biodiversity is of fundamental importance to all ecosystems and all economics (Ryan 1992).

The many values of biodiversity and its importance for development suggest why biodiversity conservation differs from traditional nature conservation. Biodiversity conservation entails a shift from a defensive posture - protecting nature from the impacts of development - to an offensive effort seeking to meet people's needs from biological resources while ensuring the long-term sustainability of earth's biotic wealth. It thus involves not only the protection of wild species but also the safeguarding of the genetic diversity of cultivated and domesticated species and their wild relatives (WRI, IUCN & UNEP 1992). This goal speaks to modified and intensively managed ecosystems as well as natural ones, and it is pursued in the human interest and for human benefit. In sum therefore, biodiversity conservation seeks to maintain the human life support systems provided by nature, and the living resources essential for human development (*ibid.*).

2.2.2 Incentives for conserving biodiversity

To many people, the most immediate reasons for caring about biodiversity are instrumental and utilitarian (Randall 1993). A diversity of species in a variety of viable ecosystems serves as an instrument for people seeking to satisfy their needs and preferences. Many of the instrumental services that nature provides for people are many such as raw materials, amenity values and ecosystem support services. Amenity values include use values and existence values. Use values include aesthetic and recreation values. Existence value arises from human satisfaction from simply knowing that some desirable thing or state of affairs exists. Some attempts to develop a rationale for preserving biodiversity focus on these kinds of services (*ibid.*). Many biotic resources have proven valuable to people. Yet many species have not been catalogued and systematically evaluated for their commercial potential. Since many of the species we know have proven useful, it sounds logical to expect that many of the presently unknown or poorly understood species will turn out to be useful later as a result of technological progress (Bishop 1978, Randall 1993). Consequently, the preservation of any species is worth something to humans and if benefits outweigh costs (including financial and opportunity costs) this forms an economic incentive to conserve biodiversity (Randall 1993).

In the context of biodiversity, an incentive for conservation is "any inducement which is specifically intended to incite or motivate governments, local people, and international organizations to conserve biological diversity" (McNeely (1993). He further notes that incentives can be used to effectively divert land, capital and labour towards conservation. Economic incentives often are used to alter behaviour by changing prices. Incentives can ensure more equitable distribution of the costs and benefits of conserving biological resources, compensate local people for losses suffered through regulations controlling exploitation, and reward the local people who make sacrifices for the benefit of the larger public. Incentives are clearly worthwhile when they help conserve biological resources, at a lower economic cost than that of the economic benefits received. Whereas a perverse incentive is "one which induces behaviour which depletes biological diversity", a disincentive is "any inducement or mechanism designed to discourage depleting of biological diversity often involving the use of regulations". Together incentives and disincentives provide the "carrot" (side payments) and "stick" (sanctions) for motivating behaviour that will conserve biological diversity, and correct the problems which have been caused by perverse incentives (*ibid.*).

In an economics perspective, issues of biological diversity can be viewed at three levels namely: international, national and local (McNeely 1993). At international level, impacts of global economic policies such as commodity prices on biodiversity is the major issue to deal with. Since conservation of biodiversity also provides economic benefits, economic incentives should be provided to the governments at international level, for instance through favourable terms of trade or through the Global Environment Facility. At the national level, the issue for governments to deal with is the impact of their policies on the biodiversity of their countries, Hence they should consider the utility of using a combination of economic incentives (such as different access to resources, compensation for animal damage, subsidies, grants, interest free loans, differential fees and tax breaks), and economic disincentives (such as fines and withholding of benefits) to

promote conservation objectives. Governments should also see the need to address the problem of perverse incentives as economic instruments which promote the destruction or extinction of biodiversity. Many government subsidies and foreign assistance projects have had and still have such effects. This is also observed in the Global Biodiversity Strategy (WRI, IUCN & UNEP 1992). For example in Tanzania, past government interference with customary landuse rights through forced resettlements in "Ujamaa villages" made rural people reluctant to make long-term investments in tree planting and other practices which could conserve biodiversity (IDA 1992). At the local level, agencies responsible for conserving biodiversity should provide incentives as a motive to enhance the performance of their staff, improve relations with surrounding communities and also provide long-term financial support to the whole issue of biodiversity. Empirical evidence from several places (Mcneely 1993) indicate that economic incentives can enable governments and the private sector to support national conservation objectives more efficiently than can traditional regulatory approaches such as "policing" protected area boundaries.

One crucial aspect is that people, particularly in those places where loss of biodiversity is at maximum, should be committed to work on biodiversity conservation. A skeptical or unaware public may not act in the way expected. Brandon & Wells (1992) also observed this inseparable link between economic activity and biodiversity conservation. They note that the challenge of conserving biodiversity is too comprehensive and inclusive to be met on public land alone. Nor is it realistic to think that conserving biodiversity is nothing more than establishing parks and preserves. Only a small fraction of the earth's surface will ever be under the protective status of a national park or forest reserve and the least protection is likely where it is needed the most - in the tropics. Hence we cannot remove people and resource use from the system and create pristine forests, nor can we somehow return to pre-settlement conditions. Conserving and enhancing biodiversity must therefore become an integral part of natural-resource management on the 95% of the landscape that sustains a wide variety of human economic activities and resource use, including timber harvesting and food production. Furthermore, at regional, national and global scales, major efforts to maintain biodiversity must occur outside parks, preserves and forest reserves - on lands having a variety of uses and ownership. Conservation measures are likely to be most successful when they provide real and immediate benefits to local people (McNeely 1993).

2.2.3 Individual's criteria for biodiversity conservation

The primary factor explaining biodiversity loss is landuse conversion which is also a major cause of deforestation (Adger & Brown 1994, Pearce & Moran 1994). It becomes prudent then to understand why landuse conversion takes place. For the individual, the landuse decision is whether to conserve an area of tropical forest or to develop it by conversion to another landuse such as agriculture. Based on economic theory, this decision is often determined by relative profitability or rate of return of the two options. Within the conservation option are included sustainable use of the forest for uses such as agroforestry or nontimber forest products such as medicinal plants, ecotourism etc. In this case the relevant rates of return are those that accrue to the individual. No account is taken of any returns to society or to the world as a whole. Based on Pearce and Moran (1994) the individual's decision to conserve or use the forest

sustainably will be right one if:

Rate of return from SUB > Rate of return from development,

where, SUB = sustainable use of biodiversity i.e. the conservation option.

This can be written as:

$$B(\text{SUB}) - C(\text{SUB}) > B(\text{DEV}) - C(\text{DEV}) \quad [2.1]$$

or

$$B(\text{SUB}) - C(\text{SUB}) - [B(\text{DEV}) - C(\text{DEV})] > 0 \quad [2.2]$$

where,

B(SUB) = the benefits of sustainable use of the forest

B(DEV) = the benefits of traditional development of the land such as agriculture, forestry or industry

C(SUB) = the costs of the sustainable use option

C(DEV) = the costs of the development option.

Equations [2.1] and [2.2] simply say that the returns to the individual or net benefits from sustainable use of biodiversity (SUB), should exceed the net benefits from development if conservation is to be preferred to development.

Due to the individual's high time preference motive, reinforced by mortality risks, benefits now than later are preferred. Thus based on economic theory, the relevance of time has to be addressed by discounting the costs and benefits in order to permit comparison of gains and losses that occur over different time periods. Therefore, allowing for time, equation [2.2] can be restated as follows:

$$PV[B(\text{SUB}) - C(\text{SUB})] - PV[B(\text{DEV}) - C(\text{DEV})] > 0 \quad [2.3]$$

where, PV = present value obtained by discounting benefits and costs at a given discount rate.

Other symbols remain as in equations [2.1] and [2.2].

An insight to what is happening with land conversion can be deduced from equation [2.3]. If the value of SUB is low and that for DEV is high, then, other things being equal, land conversion will take place. This means that, from the viewpoint of the individual, it is more profitable to "develop" than to conserve a tropical forest. One important implication is that, if the benefits of SUB accrue in an unmarketed form such that there are no obvious markets for them, or they accrue to other people and may be in another country, like existence value, then the individual has no incentive to take account of them. Since the benefits of SUB are often intangible, the individual's rate of return from conservation often appears very low, even zero. Coupled with discounting which can make the nonsustainable use preferable to the sustainable use, tropical forest clearance becomes imminent causing biodiversity loss or its reduction. The individual's knowledge that there is some further forest area that can be colonized once the existing one is depleted, adds to the incentive to deforest (Pearce & Moran 1994). Thus, two factors already provide some insight into why deforestation and hence biodiversity loss appears to be "economically rational" from the individual's viewpoint. First, the returns from clearance may simply be higher than the returns from conservation because the latter may consist of non-market benefits or benefits that accrue to people other than the individual. Second, the effect of discounting is to discriminate against sustainable uses of the land if those uses have lower initial returns, even though the returns last much longer (*op.cit.*).

2.2.4 Society's criteria for biodiversity conservation

From the social standpoint, the decision of whether to conserve the tropical forest or to develop it by conversion to other landuses, requires adjustment for redefining equation [2.3] and also finding out if society's discount rate resembles that of the individual. As shown earlier in section 2.2.1, the benefits of conserving biodiversity can be divided typically into use values and nonuse values. In mathematical notation this can be written as follows:

$$\text{TEV}(\text{SUB}) = \text{UV} + \text{NUV} = \text{DUV} + \text{IUV} + \text{OV} + \text{BV} + \text{XV} \quad [2.4]$$

where, UV = use value, NUV = non use value, DUV = direct use value, IUV = indirect use value, OV = option value, BV = bequest value, XV = existence value. Another adjustment to individual's standpoint arises from the fact that both use and nonuse values can reside in the host country or globally (i.e. all countries other than the host country. Using "c" to denote country and "g" to denote global, the Total Economic Value of biodiversity conservation can be expressed as follows:

$$\text{TEV}(\text{SUB}) = \text{UV}_c + \text{UV}_g + \text{OV}_c + \text{OV}_g + \text{BV}_c + \text{BV}_g + \text{XV}_c + \text{XV}_g \quad [2.5]$$

The expression for the society's cost benefit rule becomes that, sustainable use of biodiversity will be preferred if:

$$\text{PV}[\text{TEV}(\text{SUB}) - \text{C}(\text{SUB})] - \text{PV}[\text{B}(\text{DEV}) - \text{C}(\text{DEV})] > 0 \quad [2.6]$$

All symbols in equation [2.6] remain as defined earlier. The requirements for the comparison of sustainable landuse and its opportunity cost, the foregone development values, can be gleaned from equation [2.6]. It shows what is needed for sustainable use of biodiversity to be preferred over traditional development landuse if the host country standpoint is taken, and if that host country seeks to secure the biggest gains in societal efficiency. Based on Equation [2.6], conservation of biodiversity is preferred if the gains to the country are greater than the costs, and that those gains would be even larger if the country can "capture" some of the global use and nonuse values. Once again, if the individual does not get part of the country's gains from conservation, or part of the global gains, then the individual has no incentive to act in accordance with equation [2.6], but is most likely to operate in accordance with private gains and losses. This conflict between private, social and global returns, to a great extent, explains why biodiversity is being reduced. Thus equations [2.3] and [2.6] are the fundamental criteria needed to establish why biodiversity loss occurs. Generally, if social, global and private costs and benefits diverge or when private and social rationality do not coincide, there is a strong incentive to convert tropical forest land to other landuses causing biodiversity loss (Boj  1991, Pearce & Moran 1994).

2.3 The biodiversity crisis: losses of biodiversity, their causes and strategies for conservation

It is claimed by some scientists that the world is in the midst of a global biodiversity crisis and they estimate that in the next 25 years, humans will destroy more species than the entire process of natural selection has culled in the past 3.5 million years (Thomas & Straley 1993). This biodiversity crisis, although also taking place elsewhere, is most severe in the tropics where rainforest clearing may be dooming to extinction as many as 6000 species every year (*ibid.*). WRI, IUCN & UNEP (1992) sum up by stating that the crucible of extinction is believed to be in the tropical forests since about 10000 species are extinguished each year because of tropical deforestation. It has been estimated that nearly 150 species each day are condemned to extinction

through forest destruction and land degradation in the tropics (Mackinnon *et al.* 1986). Around 10 million species live on earth according to the World Resources Institute best estimates, and tropical forests which cover only 9% of the earth's land surface, house between 50 and 90 percent of this total. About 17 million hectares of tropical forests are now being cleared annually and scientists estimate that at these rates, roughly 5 to 10 percent of tropical forest species may face extinction within the next 30 years (WRI, IUCN & UNEP 1992). These estimates may prove conservative, however. A single hectare of rain forest typically contains between 100 to 300 different tree species which is nearly a half of the number found in all northern Americas (Sharma 1992).

Rates of tropical forest loss are accelerating, and some particularly species-rich forests are likely to be largely destroyed in our lifetime. Some scientists believe that about 60000 of the world's plant species, and perhaps even higher proportions of vertebrate and insect species, could become extinct over the next three decades unless deforestation is slowed down immediately. Many of the extinguished species have economic value to humans and the environment as a whole. Figure 2.3 illustrates prediction in percent of tropical forest species likely to be sentenced to extinction in coming decades. Between 40 and 60 percent of tropical species in most countries are endemic to specific locations, thus destruction of such areas or places can eliminate the entire species. The biodiversity of marine and freshwater systems faces serious loss and degradation. Perhaps the hardest hit of all are freshwater ecosystems, battling long-term pollution and the introduction of many alien species. Marine ecosystems too are suffering from the loss of unique populations of many species and are undergoing major ecological changes.

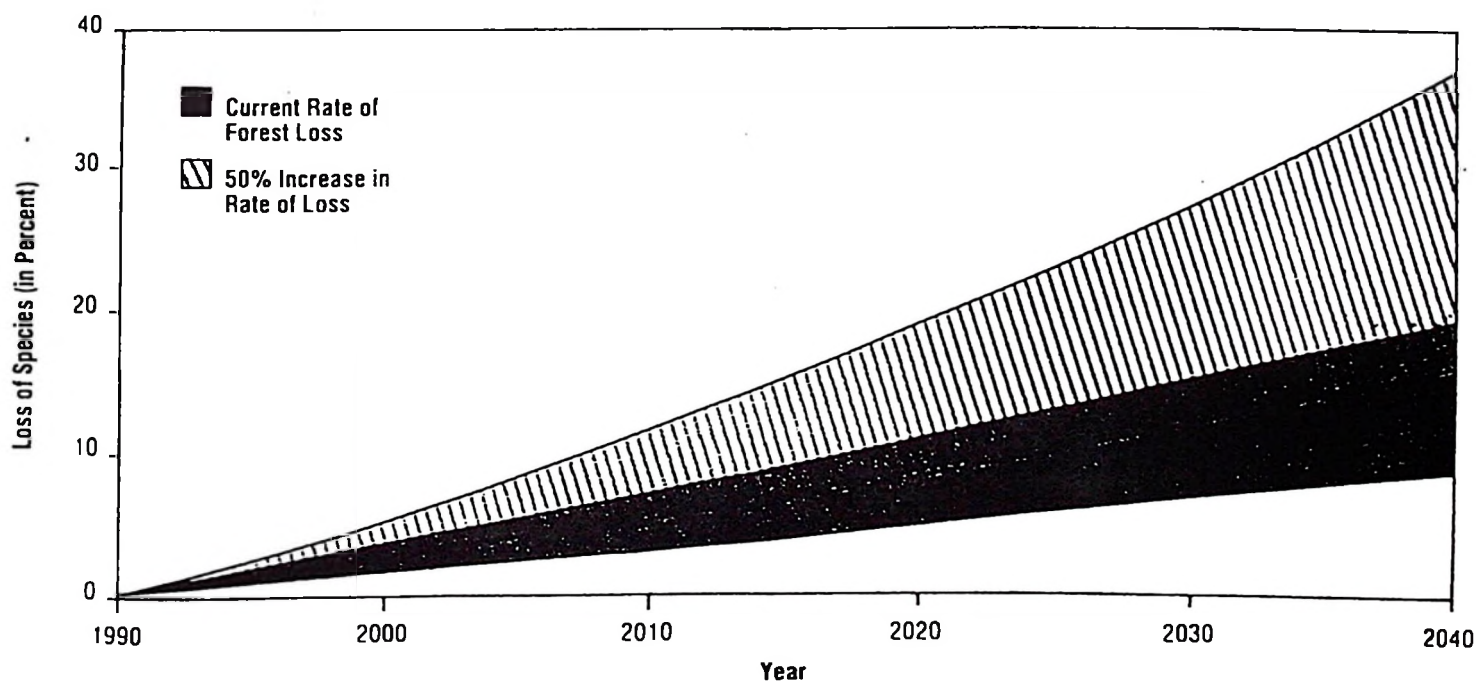

Figure 2.3. An illustration of prediction in percent of tropical forest species likely to be sentenced to extinction in coming decades. Source: Global Biodiversity Strategy (WRI, IUCN & UNEP 1992), p. 8.

A major concern about the loss of biodiversity arises from economics, social needs and ethical values that the society attaches to biological resources. Although people disagree about the degree of biodiversity reduction, a consensus exists that maintaining biodiversity requires protection of habitat and that in light of insufficient knowledge, conserving threatened biological resources and habitat is prudent (Sharma 1992). Some of agriculture biological impacts are obvious, for example expanding farms that "eat" into forests and wetland, also increased reliance on chemical input and machinery, has reduced to a greater extent, the biodiversity (Ryan 1992). Worldwide over 700 extinctions of vertebrates, invertebrates and vascular plants have been recorded since 1600 (WRI; IUCN & UNEP 1992). Habitat loss not only precipitates species extinction, it also represents a loss of biodiversity in its own right.

In many countries, relatively little natural vegetation remains untouched by human hands. Worldwide, some 492 genetically distinct populations of tree species (including some full species) are endangered (*ibid.*). This loss of genetic diversity could imperil agriculture and other economic activities. The loss of genetic species and ecosystem diversity both stems from and invites the loss of cultural diversity. Diverse cultures have bred and sustained numerous varieties of crops, livestock and habitats. By the same token, the loss of certain crops, the replacement of traditional crops with export crops, the extinction of species embedded in religion; mythology, or folklore, and the degradation or conversion of homelands are cultural as well as biological losses. The current loss of biodiversity has both direct and indirect causes. The direct mechanisms include habitat loss and fragmentation, invasion of introduced species, the overexploitation of living resources, pollution, global climate change, and industrial agriculture and forestry (WRI, IUCN & UNEP 1992). But these are not the root of the problem. Biotic impoverishment is an almost inevitable consequence of the ways in which the human species has used and misused the environment in the course of its rise to dominance.

In accordance with the Global Biodiversity Strategy, the roots of the biodiversity crisis are therefore not "out there" in the forest or on the savanna, but embedded in the way in which the human species has progressively broadened its ecological niche and appropriated even more of the earth's biological productivity. Hence the six fundamental causes of biodiversity loss are as follows: (i) the unsustainable high rate of human population growth and natural resource consumption; (ii) the steadily narrowing spectrum of traded production from agriculture, forestry and fisheries; (iii) economic systems and policies that fail to value the environment and its resources; (iv) inequity in the ownership, management and flow of benefits from both the use and conservation of biological resources; (v) deficiencies in knowledge and its application; (vi) legal and institutional systems that promote unsustainable exploitation. Folke, Mäler and Perrings (1992) identify the economic and social driving forces that cause species extinction as: poverty, human population growth, human production and consumption patterns, legal, institutional, technological and cultural aspects, improper or complete lack of property rights as well as underlying world views of human relationships with nature. These must be taken into account if biodiversity conservation is to succeed (*ibid.*). Therefore just as biological diversity is an essential resource for sustainable development, finding sustainable ways to live is essential if biodiversity is to be conserved. As people awaken to the damage unsustainable development is increasingly inflicting on the web of life and the human prospect, the search for solutions must

turn to the way people live. Devising sustainable ways to live becomes a critical element for conservation of biodiversity. Moreover, successful action to conserve biodiversity must address the full range of causes of its current loss and embrace the opportunities that genes, species, and ecosystems provide for sustainable development.

The goal of biodiversity conservation is supporting sustainable development by protecting and using biological resources in ways that do not diminish the world's variety of genes and species or destroy important habitats and ecosystems (WRI, IUCN & UNEP 1992). Since this goal is broad, any biodiversity conservation strategy must also be broad in scope. But the campaign can be broken down into basic elements: saving biodiversity, studying it and using it sustainably and equitably. "Use" does not, however, automatically imply consumption. Often, the best economic use of biodiversity may be to maintain it in natural state for its ecological or cultural values, as in the case of forested watersheds or sacred groves (*ibid.*). The biodiversity conservation agenda must encompass much more than concern for protected areas, threatened species, zoos or seedbanks and its constituency must be broad-based. It has to take place within a wider context of the move toward sustainable living. New mechanisms for discussion, negotiation and common action are all essential at the individual level, global level, and in between. Conservation efforts begin in the fields, forests, watersheds, grasslands, coastal zones and settlements where people live and work. But complementary government efforts are needed to address the many facets of biodiversity conservation beyond the capacity of local communities, or involving resources that are of national importance. By the same token international cooperation is essential, given the global nature of the biodiversity crisis and the lack of national resources in many, particularly, developing countries. Action to conserve biodiversity must ultimately be carried out where people live and work. Unless local communities have the incentives, the capacities and the attitude to manage biodiversity sustainably, national and international actions are unlikely to produce results.

The policy reforms likely to have the greatest short-term impact on biodiversity conservation will be steps taken to create conditions for conservation locally. However, local biodiversity conservation cannot succeed unless communities receive a fair share of the benefits, and assume a greater role in managing their biotic resources - be they protected areas, coastal fisheries or forests. In particular countries should ensure that people who possess local knowledge of genetic resources are rewarded financially when that local knowledge is used. Local communities should play a fundamental role in the management of wildlands, as well as in stewardship of their natural resources as a whole. In the many countries where land tenure systems and the skewed distribution of land ownership pose almost insuperable barriers to conservation, they should be changed. These conditions cannot be met without community empowerment and organization, the development of new resource - management skills, the adaptation of traditional practices to current pressures and conditions, and respect for cultural differences and basic human rights. The best way of strengthening protected areas is to better integrate them with local social and economic needs, thus increasing benefits to local communities through ecotourism and sustainable use of non-timber forest products, the establishment of effective buffer zones between protected areas and surrounding communities, compensation to local communities for lost resources, and the use of integrated conservation/development strategies in establishing protected areas.

2.4 Biodiversity in Tanzania

Tanzania has been acknowledged as one of the most important nations in Africa for conservation (NEAP 1994). However, in continental African terms, Tanzania is an extremely important nation for forest biology or rather biological diversity. The geographical and historical reasons for this, are explained by Hamilton and Bensted-Smith (1989) who note that 1100 plant species are endemic, more than 93 percent of endemic species are from the mountains of the "Eastern Arc" (defined in Monela 1995a). According to the Tanzania's National Environmental Action Plan (NEAP 1994), biodiversity is one of Tanzania's greatest assets. As a recognition of this fact some 25% of the total mainland area is set aside in protected areas including forest reserves (mainly tropical rain forests). The 13 National Parks, 16 Game Reserves, 50 Game Controlled Areas and 540 Forest Reserves are important global centres of biodiversity. Among these, four, namely: Mount Kilimanjaro, Selous Game Reserve, Serengeti National Park and Ngorongoro Crater are World Heritage Sites. These protected areas form the major tourist base for the country.

Tanzania is also among the five most diverse countries in Africa for mammals, birds and swallow-tail butterflies. For plants it is second in Africa but a full biodiversity profile of the country has not been worked out yet. Available statistics indicate that of the 100000 plant species so far documented in the country, over a quarter are endemic (Lovett 1989). Main endemic families include the *Nonaceae*, *Rubiaceae* and *Cesalpiniaceae* among others (*ibid.*). Thus Tanzania and in particular the Eastern Arc mountains are designated as one of the 20 Global Biodiversity Hot Spot Areas (NEAP 1994). Habitats with outstanding biodiversity include the Eastern Arc mountain forests, coastal forests, mangrove forests, wetlands, marine and fresh water areas. These are important sites for endemic species and contain an outstanding biodiversity. For example the Uluguru and Nguru mountains have the highest generic endemism (with 7 genera) in the whole of east Africa (Brenam 1978). Together the mountain ranges of Morogoro region form the major part of the Eastern Arc mountains with about 200 endemic species out of Tanzania's 1127 - with mainland having 1122 and Zanzibar 5 endemic species (*ibid.*). The Kimboza Catchment reserve alone (405 ha) has 17 endemic plant species which make it the richest lowland high forest in East Africa (Rodgers and Homewood 1982). There are also about 700 fish species in the lakes and rivers and about 600 fish species in marine waters of Tanzania (NEAP 1994).

Tanzania is also famous in terms of game. The Selous Game Reserve has the largest concentration of elephants in East Africa. The tree-climbing lions of Lake Manyara National Park are unique throughout the world (*ibid.*). The habitat provided by savanna and miombo woodlands as well as the isolated varied vegetation types and climate in the Eastern Arc mountains give possibility for many fauna species to thrive and find their niche in such habitats. Traditionally, fauna assessment in East Africa has been more concerned with the diversity and abundance of large mammals hence the inconspicuous small animals and invertebrates received less enthusiasm (Rodgers & Homewood 1982). A substantial number of large mammals can be seen in most of these areas. For example the Mwanihana Catchment Forest is the home of two endemic monkey species (*Colobus badiusgordonorum* and *Cercocebus galeritus*) (Nsolomo & Chamshama 1990).

Moreover, rich avifauna, some reptile, amphibian and arthropod species are also numerous (Norris 1990). Human impact in some areas has forced large mammals to confine themselves on high mountain slopes with limited altitudinal migrations (Bjørndalen 1992). The number of the animals is diminishing with time due to human pressure (*ibid.*).

Economically, biodiversity in Tanzania is also important for the sustainable supply of cash and food crops, protein, medicine and numerous plant and animal raw materials. However, many aspects of development pose a threat to the future existence of particular species and even ecosystems in Tanzania. In recent years, forest loss and fragmentation for instance has led to the concentration of endemic species in very restricted areas (NCSSD 1994). For example, Selous Game Reserve has three endemic plant species and Rondo Forest Reserve has 10 endemic species (TFAP 1989). The Eastern Arc mountains are a major centre of endemism for birds, with 14 endemic species being confined to small forest blocks. The Usambara mountains have two and Udzungwa mountains has one (*ibid.*). Endemic species usually reflect the richness of the biological diversity (Bjørndalen 1992). It is from this endemism that the Tanzania Forest Action Plan (TFAP 1989), the National Environmental Action Plan (NEAP 1994), and the National Conservation Strategy for Sustainable Development (NCSSD 1994) emphasize the need to preserve and maintain the natural environment from being devastated. They also recommended an increased effort toward conservation of the resource (biodiversity) throughout Tanzania.

2.5 Rainforests and biodiversity conservation in Tanzania

Rainforests form one important forest type in Tanzania as described in Monela (1995a). Besides their many other benefits, rain forests in Tanzania derive their high value from their high biodiversity characterized by the presence of large numbers of endemic and near-endemic species and taxa of both flora and fauna. Thus they are a home of many species of plant and animal life (Bjørndalen 1992). This feature of rain forests in Tanzania has been documented by many authors and among them are: (Rodgers & Homewood 1982, Hermansen *et al.* 1985, Lovett 1988 & 1989, Hamilton & Bensted-Smith 1989, Hamilton & Mwashia 1989, Mäther 1989, TFAP, 1989, Norris 1990, Bjørndalen 1992, NEAP 1994, NCSSD 1994) among others. Apart from the scientific importance of endemic species and taxa found in Tanzania's rain forests, many have various uses (Pócs 1990, Norris 1990, Bjørndalen 1992). The catchment role and biological diversity are the main reasons for the concern against destruction of the rain forests. Also the knowledge that destruction of these forests is an irreversible process due the difficulty to regenerate them once they are destroyed (TFAP 1989).

Tanzania's rain forests constitute one of the world's richest in plant, animal and habitat diversity. It is human impact and its associated forest loss which has led to the concentration of species especially endemic ones in these very restricted areas (NEAP 1994). The rain forests of the Eastern Arc mountains of Tanzania are a major center of endemism. The biodiversity and phytogeographical importance of the Eastern Arc mountains of Tanzania and East Africa has been a subject of wide coverage by several authors and many of these report the presence of big number of endemic, near endemic and rare taxa of both plants and animals (Polhill 1968, Hilliard & Burt 1971, Pócs 1974, 1975, 1982, 1988, 1990; Axelrod & Raven 1978, Brenam 1978, White

1978, 1983; Lovett 1988, Bjørndalen 1992). Several threatened and near-threatened species are reported to be confined to the Eastern Arc mountains (Lovett 1989, Pócs 1990, Iversen 1989 & 1991, Bjørndalen 1992).

The species richness of the Eastern Arc mountains can be illustrated by the fact that over 200 tree species have been registered in the Usambara mountains alone (Pócs 1982, Ruffo *et al.* 1989). Polhill (1968) established that more than 70 tree and shrub species are restricted in their distribution to the Nguru and Uluguru mountains. Lovett (1988 & 1989) estimated that the level of endemism of the flora of these mountains is about 25% of the species. A number of wild varieties of several cultivated crops are found in these mountains, including coffee, rice, millet, palms and banana (NEAP 1994). Moreover 40% of the world's wild coffee varieties, about 80% of the famous African Violet (*Saintpaulia pusilla*) flower plant species are also found in these mountains Bjørndalen 1992). Yet as Pócs (1990) noted, the knowledge of the flora of the Eastern Arc mountains of Tanzania is still far from complete following his discovery of several other new species in these mountains. Endemism has also been reported in the fauna of these mountain forests and endemic animal species include birds and invertebrates (Lovett 1989). Some other areas in Tanzania where rain forest endemic species are restricted have been mentioned earlier. In this study, besides investigating biodiversity aspects in the Nguru mountains, another aim is to investigate the role of buffer zones and their control mechanisms in preserving the rain forest and its biodiversity. Therefore the next section of this report gives a background on buffer zones as one tool among others for forest protection in Tanzania before analyzing how these tools have influenced forest management in the Nguru mountains.

2.6 Buffer zones as a tool for forest and biodiversity protection

Buffer zones have been defined as areas peripheral to national parks or nature reserves which have restriction placed on their use to give an added layer of protection to the nature reserve itself and to compensate villager's for the loss of access to strict reserve areas (MacKinnon *et al.* 1986). However, the term buffer zone can also be used to cover a wide range of conservation and development activities which can be applied to the areas adjacent to parks and reserves to protect them against external pressures, and deliver benefits to local people (Wells & Brandon 1993). A basic objective is to surround protected areas with vegetation which, if not completely natural does at least allow some animal and plant species to extend beyond the boundaries of the totally protected area. Sayer (1991) provides a more recent definition in which a buffer zone is defined as "a zone peripheral to a national park or equivalent reserve, where restrictions are placed upon resource use or special development measures are undertaken to enhance the conservation value of the area".

However, the definition of the buffer zone in practice is in contrast with the above cautiously proposed definitions (Wells & Brandon 1993). In practice, the buffer zone term has been used to describe almost any initiative involving people that takes place near a protected area (*ibid.*). Consequently there has been considerable confusion over some key buffer zone issues - their purpose, their location, their management, and what criteria should determine their area, shape, and permitted uses. In particular the popular idea that buffer zones are a means for the local

people to genuinely benefit from the proximity of a protected area needs qualification. In this context therefore, we shall adopt the definition of a buffer zone in practice focusing mainly on activities of local people near a forest reserve in relation to the land along the forest reserve borders. Also will emphasize on forest reserve protection as primary objective and supply of local economic benefits as secondary but important. Normally there are two types of buffer zones in use. The first type covers the areas between the village and the intended area to be preserved. The width of this type of buffer zone is not fixed. It differs from place to place or sometimes may not be properly defined depending on many factors such as village population. This study, is focused on this type of buffer zone because of its close connection with landuse practices which affect the tropical rain forest in the study area. Thus a study was conducted in such a buffer zone in Mhonda area to investigate forest-agriculture relations and their impact on the protection of the tropical rain forest. The demerits of this category of buffer zone is that the protected area owner (such as government) cannot control it fully due to lack of the legal authority, jurisdiction and mandate to take offenders to the court of law for violating the buffer zone regulations (Wells & Brandon 1993). Sometimes a large gap exist between the buffer zone concept and reality in that most protected area management agencies lack also legal authority to establish or manage buffer zones outside or even inside protected area boundaries (Brandon, Wells & Hannah 1992). This often leads to misuse of such areas treated as open access areas.

The second type of buffer zone is where the buffer zone is located within the reserved area. In the conservation context this is the best one because the owner of the protected area has full control over the area through laws and regulations which are used to protect the reserved area. In this type of buffer zone, it is not easy for the local communities to invade the buffer zone area and therefore the core reserved area may be better protected (Sayer 1991). However, in reality, plans which have provision for buffer zone activities rarely implement activities beyond physical and legal protection and provision of infrastructure for patrolling and tourism in the core protected area. An important reason is that protected area managers rarely have jurisdiction over land outside the legal limits of their park or reserve. Moreover, they rarely have training in the skills which are needed to work effectively with local communities. Institutions responsible for agricultural and forestry development sometimes do not understand that land adjacent to protected areas should be treated rather differently from similar land elsewhere. This hampers the nature reserve manager's job.

According to Sayer (1991) and Wells & Brandon (1993), buffer zones provide gradients between totally protected land and intensively used land. In general terms they ascribe to biological and social roles/benefits. Biological roles include: (i) provision of filter or barrier against human access and illegal use of the strictly protected core zone or conservation area; (ii) protection of the strictly protected core zone or conservation area from invasion by exotic plant and animal species; (iii) Provision of extra protection against storm damage, drought, erosion and other forms of damage and; (iv) extension of the habitat and thus population size of large, wide ranging species in the protected area. Social roles include: (i) provision of a flexible mechanism for resolving conflicts between the interests of conservation and those of the inhabitants of adjacent land; (ii) compensation of people for loss of access to the strictly protected core zone or conservation area; (iii) improvement of the earning potential and quality of the environment of

local people; (iv) building local and regional support for conservation programmes; (v) safeguarding traditional land rights and cultures of local people and; (vi) provision of the reserve of animal and plant species for human use and for restoration of species populations and ecological processes in degraded areas.

According to Sayer (1991) and Wells & Brandon (1993), the following conditions need to be put in place in order to maximize the role of buffer zones: (i) maintenance of tree cover and habitats to near-natural state; (ii) maintenance of vegetation in buffer zones to resemble that of the protected area, both in species composition and physiognomy; (iii) ensuring that biological diversity in buffer zones resembles that in the protected area; (iv) retaining as far as possible the capacity of the ecosystem in the buffer zone to recycle soil nutrients. Similarly to avoid activities in the buffer zone that have negative impacts on the physical structure of the soil or on its water-retaining capacity; (v) finally, exploitation of buffer zones should make use of traditional, locally adapted lifestyles and resource management practices. To enhance the role of buffer zones in conservation, Wells and Brandon (1993) studied in 14 developing countries the challenges which has arisen in operationalizing the concept of buffer zones. They concluded that despite some critical constraints in managing buffer zones, they still have a high potential in conservation of biodiversity and bringing sustainable development.

The idea of supporting buffer zones projects has proved very attractive to many donors of international development assistance (Sayer 1991, Wells & Brandon 1993). Many of these organizations see the need to invest in resource conservation or preservation of natural areas. However, many of these agencies for ideological reasons, resent to invest their money in "policing" activities around nature reserve areas especially since these activities were usually aimed at limiting the activities of those poor rural people who were supposed to be the prime beneficiaries of the aid programmes. Buffer zone projects combine the two primary aims of development assistance: the wise use of resources and increased well-being of poor rural people. Hence, the reason for an enormous upsurge of interest in buffer zones during the 1980s (Wells & Brandon 1993) and in consequence several buffer zone projects came into practice. Many of these externally funded projects have already failed because they relied on foreign technical staff. This is due to the fact that they often require expertise which fell outside the training and normal activities of the staff of protected areas, and they do not fit easily into the organization of land management in the countries concerned. Conservation organizations have in consequence focused on technologies for the management of buffer zones. Different groups advocate agroforestry, tree plantations, natural forest management, sustained yield hunting and a plethora of other landuses which are considered to be ecologically well-adapted. The term "ecodevelopment" has been coined in consequence and it applies to the sorts of activities that people perceive as being appropriate for buffer zones (Sayer 1991). Some several earlier buffer zone projects have succeeded while many have had disappointing results (Wells & Brandon 1993).

Often protected areas are located in remote places where Government institutions are relatively weak. Moreover, Central Government authorities often show little interest in buffer zone problems. Some useful buffer zone initiative have been based upon informal arrangements, negotiated between enterprising local forest staff and their local counterparts in other government

agencies. Complex legal and administrative measures have sometimes been perceived as necessary to meet the objectives of protecting the forest reserve. Such measures often contribute little to solving practical problems on the ground. Moreover, such informal arrangements which work well for small-scale intervention may be less appropriate as the scale of buffer zone activities increases (*op.cit.*). In the Nguru mountains the buffer zone area around the tropical rainforest represent a misused or mismanaged land due to increased human activity as a result of the growing population which naturally is associated with more demand for farmland and forest products. Due to population pressure, the rainforest and its surrounding area is threatened. Consequently, the buffer zone area has become an area of much activity and rapid deterioration. New systems, ideas and action are needed to bridge the gap between the immediate needs of local people and the long-term objectives of the protected area, in this case the Forest Reserve. This study aims to pursue this role in order to improve management and protection of the tropical rainforest in the Nguru mountains.

2.7 Review of related studies in Tanzania with reference to biodiversity uses, catchment forests and buffer zones

Due to various reasons, catchment forests in Tanzania are not properly managed (Nsolomo & Chamshama 1990). Lack of proper knowledge on these forests to enable catchment officers to draw up management plan is pointed out by Lundgrén (1985) as a snag towards better management of catchment forest reserves. Poor management has resulted in the catchment forests facing varying degrees of human interference which in recent years has caused great concern on the threat these forests are facing and the need to reverse this situation. Studying the existing human interference to understand the problem has been pointed as one basis for recommendation of future management practices. Policing forest reserves, law enforcement or planting a few rows of exotic trees along the boundary are not sufficient means to protect catchment forests under existing conditions in Tanzania. Other approaches focusing on education and involvement of people living adjacent to the forest reserves are crucial and hence the important role of buffer zones in forest protection (*op.cit.*).

Besides several biological-based studies which have been done in catchment forests of Tanzania, few studies have also been carried out to investigate the problems in catchment forests and how to mitigate them. Most of these studies point out the need to review the traditional techniques of forest protection to cope with present society needs. However most of these studies focused on reviewing the problems with no support from empirical data. These studies include those by Nsolomo & Chamshama (1990), Kaoneka (1990), Bjørndalen (1992), Lovett & Pócs (1993). Nsolomo & Chamshama (1990) studied human impacts in catchment forests in Morogoro Region and qualitatively observed changes in forest cover due to human activities particularly encroachment for agriculture, pitsawing and land use practices in areas adjacent to catchment forests. They found that human activities mainly pitsawing, collection from the forest encroachment and bushfires were seriously affecting catchment forests and most of these problems originate in the zone bordering the catchment forests and steadily extend into the reserved area. It was concluded that besides law enforcement, education and involvement of local communities in forest management are imperative to shift people's dependence from the forest

reserve to properly managed area outside the protected forest.

Kaoneka (1990) in his review of measures to contain problems of encroachment in natural forests in Tanzania and, Bjørndalen (1992) in his assessment of nature conservation values, biodiversity and water supply in Tanzania's vanishing rain forests both came to similar conclusions. Lovett & Pócs (1993) assessed the conditions of Catchment Forest Reserves in Tanzania with main focus on botanical appraisal. However, they noted the alarming situation resulting from human activities in and around catchment forest reserves and recommended that among other measures zoning of catchment forest reserves to provide for buffer zones, extractive forest zones and protected core zones augmented by education and community participation are crucial steps to foster effective protection of catchment forests. Kaoneka (1993) studied the impact of agricultural land use practices on catchment forests protection in the West Usambara mountains. The results showed that population growth causing increased demand for forest and land resources coupled with poverty, land use conflicts, inefficient farming practices, market and government failures are the main causes of landuse problems which hamper forest protection efforts in the area. The study led to the conclusion that it is necessary to address these problems in order to reduce human impacts in catchment forests in the Usambara mountains.

As for the evaluation of the role of buffer zones in protection of reserved areas in Tanzania, there are no studies specific to forestry which have been published. However, the concept of buffer zones in protecting reserved natural forests is mentioned in some recent literature in Tanzania particularly Mitzlaff (1991), Catchment Forestry Project (CFP 1991, 1992 & 1993), The Tanzania Forestry Action Plan (TFAP 1989), The National Environmental Action Plan (NEAP 1994) and the National Conservation Strategy for Sustainable Development (NCSSD 1994). The widest use of buffer zones in the protection or control of reserved areas has been in National Parks particularly in the Maasai Steppe as reported by Mwalyosi (1990) in his study on resource management in the Maasai Steppe of northern Tanzania. The usual practice in protection of national Parks has been to establish a buffer zone in the area between the national park and the village in communities adjacent to national parks (Mwalyosi 1990, NEAP 1994). Since the national Parks lack legal control of such areas, they have failed to achieve the intended objectives (*ibid.*). In forest protection, planting few rows of exotic tree species along the forest reserve legal boundary has been practiced to a limited scale with little success due to lack of resources (CFP 1991). Thus there is need to investigate various ways in which the role of buffer zones in forest protection can be enhanced.

Kowero and Hofstad (1989), based on literature and experience, estimated the average annual monetary value of various nontimber forest products in Tanzania. Total value was estimated using average price for broad categories of forest products and average annual harvest statistics. Forest products such as cashew nut and fruits which are usually accounted for under the domain of agriculture were not included. Although their estimates may not be accurate and may still underestimate the value of nontimber forest products, they report a relatively high countrywide average annual total monetary value of T.Shs. 12620 million (1989 prices, 1 USD = T.Shs. 192) for these products. The combined value of some nontimber forest products such as wattle extract, beeswax and honey was estimated to be several times more than the value of timber.

3.0 THE STUDY METHODOLOGY

3.1 The Study area

Data for the study were collected from the rainforest in Mhonda area (6°08'S; 37°35'E at 540 m a.s.l.), on the eastern part of the Nguru mountains in Tanzania. Mhonda is just on the periphery of the rainforest and from Mhonda Mission, there is a relatively easy access to the rainforest. The location of the Nguru mountains, Mhonda area and Nguru South Forest Reserve is described in figures 1.1, 3.1 and 3.2. in Monela (1995a). Other features regarding description of the study area such as climate, soil and geology, land use, social anthropology and ecology are also presented in Monela (1995a). The Nguru mountains extend for more than 60 km in the NNE-SSW direction from about 5°5'S and 37°45'E to about 6°20'S and 37°20'E and at the widest they are about 30 km. The inhabitants of the area (indigenous and immigrants) practice peasant farming and collection of forest products from the rainforest to meet household needs. Their economy is partially integrated to the market economy hence a proportion of farm produce as well as forest products are locally marketable. However, most of the production is for household consumption.

3.2 Data collection methods and analysis

Primary data for the study were collected by interviewing people and by field observations in the tropical rainforest and in the zone adjacent to the rainforest boundary. Secondary data were obtained through informal discussions with relevant people and from various documents. No earlier studies have been carried out in the Nguru mountains to assess the use of plant species in the rainforest or to evaluate the existing forest control practices used to protect the tropical rain forest. The data collected through interviews and field observations in this study is thus a contribution to the existing knowledge on the use of tropical rainforest species and protection of the tropical rainforest. For primary data collection, a total of 59 households randomly sampled, were surveyed using questionnaire (Appendix 1) and interviews at homesteads and in the field with both men and women participating. Due to time and resource limitations it was not possible to stratify the households to cater for inter-household variation which was assumed to be small and therefore cannot affect the overall conclusions of the study. Most of the households sampled had farmholdings in the zone adjacent to the Forest Reserve and collected forest products from the tropical rainforest in which they have easy access.

Interviews were conducted during the period 1993/94 by the researcher and 5 male assistants (all University graduates with some experience of survey work). Living in the village for the entire survey period, they walked to all areas covered by the survey observing and talking to people with good knowledge of the community and its environment mainly extension staff, leaders and sampled households. This facilitated collecting information from well informed sources with assistance from village guides. During the survey, the interviewers took time to explain the purpose of the survey, noted the answers in the presence of the interviewees and filled in the questionnaire at the same time. The assessment of the interview process (i.e. quality of the data obtained and interview atmosphere) was also noted and evaluated through cross-checking of

questions. The survey questions were designed to yield information in respect to objectives of the study. Questions were asked on key issues such as timber and nontimber uses of tropical rainforest species, existing forest control practices to protect the tropical rainforest, violation of forest rules, incentives to protect the rainforest and non-attractive values of the forest. Collection from the rainforest was evaluated by getting information on type, quantity and value of forest products per species level collected from the rainforest. This information was collected through ethnobotanical interviews, augmented by field observations. The ethnobotanical interviews focused on uses of plants at per species level and quantities collected and local monetary value.

More information on the use of species and quantities collected was also elicited from other key persons in the village who directly use plant species. The main ones were: Beekeepers, local herbalists, charcoal makers, loggers, woodfuel gatherers, carvers, local traders and village elders. Interaction with these key persons partly relied on meeting them in the field (spontaneous exchange). It also depended on the deliberate effort to look for them with help from a village guide who identified them. Additional questions were asked which enabled formulation of impressions with regard to the people's attitudes toward such issues as non-attractive values of the forest, action against culprits and incentives to protect the forest reserve. From a combination of market observations and interviews with buyers and sellers and own estimation, the local current market value of timber and nontimber forest products collected from the forest was estimated. Local current market value of marketable products was obtained from market observations, and interviews with buyers and sellers. Monthly surveys at the market and household visits were used to collect average retail prices for various marketable forest products such as fruits. For timber prices, local forest officers also provided information. The local current market value for non-marketable forest products was estimated based on the local current market value of substitute goods or by estimating what the current cost would be if the consumed quantity has to be bought from the market. This information was used in indicating the size in percent of the current value of forest products (i.e. timber and nontimber) in the household economy. The major cost component of the collection costs is time spent during collection and manual labour used. These were not included in the value estimates since labour has opportunity cost close to zero due to limited labour use options and excessive leisure time. Other costs are negligible because most of the activities are done manually.

Field observation for primary data collection involved frequent visits (twice per week) to the Forest Reserve and the buffer zone. These visits involved: collection of botanical specimens for the botanical inventory to provide scientific identification of species and to assess species richness of the tropical rainforest; monitoring of human impacts (such as stumps left after cutting down trees, gaps, encroachment, bushfires etc.); direct monitoring of timber and nontimber forest product collection from the rainforest and its buffer zone; assessing Forest Reserve control practices and observation of vegetation changes. Direct observation of collection from the forest involved placing monitors at specific routes used to enter and leave the forest and by on-site observation within the rainforest. The aim was to record the extensive use of the rainforest by monitoring the annual quantities of forest products collected from the rainforest. Plants and their uses were recorded and botanical specimens taken in the forest especially during transect walks across the forest at different elevations and also during visits to specific natural forest types. A

local guide explained the uses of various species which were later verified by responses in the questionnaire and interviews. Local names were recorded in "Kiswahili" and "Ngunu" languages.

The identification of botanical specimens collected relied on field keys, local expertise and verification at the Sokoine University of Agriculture Herbarium and the National Tree Seed Centre both based in Morogoro. Additional information to supplement primary data was collected from relevant secondary sources mainly village, Ward, and Divisional leaders, local forest authorities, the Morogoro Catchment Forest Project staff at district and regional level, district and regional forest staff and documents particularly periodic reports. The data collected were analyzed and presented based on descriptive statistics using frequency counts and distributions, tabular analysis and percentages. The information obtained is a necessary background for Monela (1995c).

4.0 RESULTS AND DISCUSSIONS

4.1 Context of results presentation

The results and discussions in this chapter are presented in the context of the following main perspectives: (i) Species richness as one dimension of biodiversity and the use of tropical rainforest species in the Nguru mountains; (ii) Existing forest control measures currently practiced to protect the tropical rainforest and its biodiversity.

4.2. Biodiversity and endemism in the Nguru mountains

4.2.1 Species richness in the tropical rainforest and in the adjacent zone

From the botanical inventory conducted in this study, the tropical rainforest in the Nguru mountains is a rich source of various tropical plant species for various uses. The species richness includes a total of 72 plant families, 165 genera and 176 plant species which were enumerated in the botanical survey (Appendix 2). About 86 plant species (49% of total enumerated species) were identified in the survey as most frequently locally used to meet household needs. These (together with their local names) are presented in Appendix 3. Based on species richness as one important dimension of biodiversity, coupled with the high level of endemism, we can suggest that the Nguru mountains constitute one of the important biodiversity areas in Tanzania. For the purpose of assessing the impact of human activity on species diversity, species in the zone adjacent to the rainforest boundary were also enumerated and compared to the number of species inside the tropical rainforest. Results showed that intensive use of the area adjacent to the rainforest has drastically reduced species richness and diversity to a considerable extent because there were only 19 species recorded, which is about 11% of total enumerated species in the rainforest (Appendix 4). This points to the importance of limiting human activity inside the rainforest to protect biodiversity. The survey in the buffer zone area, which during gazettement of the Forest Reserve was specially reserved as a buffer zone to provide a physical barrier to human impact in the core rainforest zone, and extend the forest habitat, has been encroached for cultivation and settlement. More than 60% of the area is now fully occupied by crop fields which have replaced the natural vegetation or reduced it to secondary forest.

Due to vegetation changes in the buffer zone area, the microclimatic changes between the core Forest Reserve and the buffer zone area were discernible easily as it turned cooler and moist as one entered the rainforest. The vegetation cover also became denser with the soil getting laden with decomposing litter. Some indigenous plant families still found in the buffer zone area are: *Clusiaceae*, *Zingiberaceae*, *Agavaceae*, *Leguminiceaea*, *Euphorbiaceae*, *Moraceae*, *Ulmaceae*, *Labiatae* and *Rubiaceae*. These have survived human impact especially agriculture-related. During the survey households were asked to identify common species found in the buffer zone area. The responses are presented in Table 4.1. In the buffer zone patches still rich in species were found mainly along stream banks and on slopes of inaccessible hill tops. Appendix 5 presents main species which were enumerated along river/stream banks. These constituted about 5% of total enumerated species. Among these, some are important timber trees which have been

left out not by a deliberate effort to retain them but because they cannot be easily accessed for exploitation.

4.2.2 Endemism of plant species in the tropical rainforest

Due primarily to their long "undisturbed" evolution and periodic isolation, the Nguru mountains have incredibly rich and diverse flora with an exceptionally high incidence of species and generic endemism. Out of the species enumerated in the botanical survey, 7 species (about 4% of total enumerated species) are specifically endemic in the Nguru mountains and 26 species (about 15% of total enumerated species) are endemic in the "Eastern Arc" mountains including the Nguru mountains (Appendix 6). One remarkable endemic genus in the Nguru mountains is the cultivated African violet (*Saintpaulia*). Examples of families with a high percentage of endemic trees and shrubs in the "Eastern Arc" mountains which include the Nguru mountains, with percentage of endemism in brackets are: *Gesneriaceae* (73%), *Melastomataceae* (54%), *Balsaminaceae* (51%), *Rubiaceae* (36%), *Annonaceae* (35%), and *Orchidaceae* (31%). Examples of genera which are endemic or near endemic (with families in bracket) are: *Cephalosphaera* (*Myritaceae*), *Diomychastrum* (*Melastomataceae*), *Dolichometra*, *Pseudonesohydyotis* and *Rhipidiantha* (*Rubiaceae*), *Englerodendroa* (*Caesalpiniaceae*), *Linnaeopsis* and *Saintpaulia* (*Gesneriaceae*), *Platypterocarpus* (*Celastraceae*) and *Zimmermannia* (*Euphorbiaceae*).

The presence of a rich gene pool of plants and animals in The Nguru mountains has also been mentioned by Poc's *et al.* (1989), Pócs (1990), Poc's, Temu & Minja (1990), Nsolomo & Chamshama (1990), Chamshama, Nsolomo & Persson (1990), Norris (1990), Nsolomo & Chamshama (1990) and Bjørndalen (1992). The conservation of the Nguru mountain forests is tailored towards preservation of this gene pool which has a great potential for benefitting future development (TFAP 1989). The clearing of the pristine rainforest from the Nguru mountains can be expected to result in some impoverishment of the biological diversity in those mountains and possibly the global tropical rainforest biome because of the uniqueness of some of their flora. Regarding faunal biodiversity very little research has been carried out in the Nguru mountains to study its faunal biodiversity. Due to the numerous endemic, near-endemic and rare animal species which have been found in the other Eastern Arc mountains of similar vegetation type and climatic characteristics (Lovett & Thomas 1988), one can expect similar situation in the Nguru mountains where human disturbance has been relatively less. During the survey in the area, some large mammals such as buffaloes, bush pigs and various monkeys and even leopards were seen on the less densely populated North-West slopes of the mountains. Also some hunting was practiced on the eastern slopes and the animals often caught were rock hyrax, various monkeys and those in Appendix 8.9. Large bats, avifauna, reptiles, amphibians, arthropods and birds are many. Therefore, one importance of the Nguru mountain forests as a genetic resource lies in the biodiversity of species which live in it. There is a tacit need to protect this biodiversity in order to benefit from the potential economic value of this biodiversity. Since only a small proportion of the flora has been classified, the chances of finding new plants which can be of use to mankind is considerable.

Table 4.1. Responses to indicate common species in the zone adjacent to the tropical rainforest (n = 59)

	Frequency of responses	Percent of surveyed households
<i>Harungana madagascariensis</i>	43	72
<i>Abizia gummifera</i>	46	77
<i>Hoslundia opposita</i>	5	95
<i>Newtonia buchananii</i>	8	14
<i>Entandrophragma stolzii</i>	17	29
<i>Acacia neglescens</i>	1	2
<i>Celtis zenkeri</i>	2	3
<i>Bombax rhodognaphalon</i>	1	2
<i>Myrianthus holstii</i>	4	7
<i>Fagaropsis angolensis</i>	1	2
<i>Strombosia scheffleri</i>	28	42
<i>Dracaena species</i>	5	14
<i>Bridelia micrantha</i>	35	59
<i>Macaranga species</i>	13	22
<i>Milicia excelsa</i>	6	10
<i>Antiaris toxicaria</i>	3	5

Source: Own field data

4.2.3 Biodiversity benefits derived from the use of tropical rainforest species in the Nguru mountains

In this section are presented the important uses of tropical rainforest plants in the Nguru mountains as identified during the survey. The uses are divided into two categories: (i) The present uses and; (ii) Potential uses. These uses are one major way by means of which direct benefits from the rainforest are distributed locally.

4.2.3.1 Present uses of tropical rainforest species

Various species in the tropical rainforest are used for various purposes in the Nguru mountains. Some plant uses extend even beyond the local community boundaries to the nearby urban centres. These plant uses were grouped into eight categories: (i) Timber, handicraft and furniture; (ii) Fuelwood; (iii) Vegetables; (iv) Wild fruits; (v) Seeds and nuts; (vi) Local medicine; (vii) Honey collection (i.e. making and hanging beehives); (viii) Gum and sap. Out of 176 species enumerated in the tropical rainforest during the botanical inventory, 69 % were found to have established

local uses at present. Table 4.2 summarizes the species locally used for various purposes. The value of forest products consumed by an average household per year was estimated to be T.Shs. 236530 and this contributes about 39 percent of total household consumption. The value of nontimber forest products which constitute the big proportion of household consumption of forest products was influenced by several factors mainly: species in the forest (i.e. floristic richness and composition); the access to, or proximity of the market; local policy and property rights regime with regard to forest ownership and control.

Table 4.2. Uses of tropical rainforest species in the Nguru mountains

Economic use of plant	Number of plant species used	Percent of species used ¹	Value of forest products consumed by an average household per year (T.Shs./year)
Timber uses	8	4.5	17919
Fuelwood	24	13.6	111097
Vegetables	28	15.9	46589
Wild fruits	28	15.9	25087
Seeds/nuts	11	6.3	14335
Local medicine	17	9.7	10751
Honey collection	5	2.8	7168
Gum/sap	1	0.6	3584
Unestablished uses ²	54	30.7	-
Total	176	100.0	236530

Source: Own field data

Footnote: 1 Number of species for a particular use expressed as a percentage of total enumerated species in the rain forest

2 These refer to species not categorized for any specific local use in the survey

It can be gleaned from Table 4.2 that the use of plant species as a source of supplementary food is dominant since about 41 % of all enumerated species in the rain forest contribute to food production. Wild fruits and vegetables are the most commonly used food supplements from the forest. Vegetables are often pounded and boiled as relish while fruits are consumed when ripe. This wild food source is most important during the dry season when collection is done due to reduced agricultural activity and also during periods of food stress as a source of relief and convenience food. Most collection of these wild foods is done by women and children who also do the processing and storage. Fuelwood mainly in the form of firewood is another dominant use. The role of biomass energy in rural communities especially in developing countries need not be over emphasized. Like in food collection, the role of women and children in firewood collection is greatest. The local people also have the age-old practice of relying on local medicine made from locally available herbs. Only about 10% of all species enumerated were found to be used as a source of local medicine. However, this number could be even higher due to the secretive nature of local herbalists. There are several taboos associated with some local medicine practices

including concealment of some information to outsiders.

Although the number of species used for other uses is small, yet they are equally important in sustenance of welfare of the local households in the study area. For example, the role of timber is quite high as discussed under distribution of biodiversity benefits through sawmilling and pitsawing. Honey collection, sap and gums have high economic value due to their demand in the commercial market. However, the local communities have not been able to maximize the use of such products due to lack of means especially capital. Appendix 8 presents the list of various plant species used for various local economic purposes in the Nguru mountains. Since biodiversity includes animals, Appendix 8.9 lists some of the large mammals found in the Nguru mountains which are also used for food by the local communities. This study was focused on plant biodiversity, however.

4.2.3.2 Timber benefits

The most widespread use of the forest is for wood products mainly timber, fuelwood and building poles. The indigenous species widely used for timber products are: *Milicia excelsa*, *Newtonia buchananii*, *Caephalosphaera usambarensis*, *Ocotea usambarensis*, *Entandophragma excelsa*, *Khaya nyasica*, *Podocarpus milanjanus* and *Pterocarpus angolensis*. The timber from these trees is used for local building material, local furniture or is sold to timber dealers from Morogoro town. The main harvesting technique is pitsawing which has been discussed with empirical data in Monela (1995a). The economics of pitsawing in the Nguru mountains can be gleaned from the cost-benefit analysis of the pitsawing operation based on data collected during the survey in the area.

Cost-benefit analysis of pitsawing in the Nguru mountains

This section aims to analyze the financial benefits and costs of pitsawing as performed in the Nguru mountains. The mechanics of pitsawing and quantities of timber harvested are presented in Monela (1995a). This analysis therefore covers costs and benefits involved from licensing, tree felling, sawing and manual sawn timber delivery at the nearest roadside. It is done from the viewpoint of a pitsawing contractor who aims at making profit for his enterprise. Economic viability in this context implies to ensure that the pitsawing contractor has the right incentive by getting profit from pitsawing activity. Experience in Tanzania has shown that this is often pursued without regard to sustainability or other social benefits (Torstad pers. comm. 1994). The social profit aspect, though very important, was not included due to difficulty of translating positive and negative effects of pitsawing into monetary units. It is also prudent to point out at this stage that pitsawing in Tanzania operates on an informal market structure hence complicating the estimation of costs and benefits. This point is observed by Skage & Næss (1994) and also by Jaako Pöyry (1992) who observed that, regarding pitsawing in Tanzania there is no simple price trend, because the said costs, prices and other pricing elements are spontaneous, forming a complex pricing structure even from the same timber site. This point notwithstanding, costs and benefits were worked out to permit the analysis presented in Monela (1995b). According to Solberg (1988), pitsawing profit depends on factors such as physical strain, sawn wood quality,

terrain transport factors and ecological effects. He concludes that, it is worth reflecting on the high economic and financial efficiency of the traditional method of pitsawing, covering well the local demand regarding quality and price compared to the modern technological choice in sawmilling. Based on studies in Tanzania, he notes that, the earnings of pitsawyers were higher than casual labourers. The earnings of the pitsawyers amounted to approximately T.Shs. 28 per 8 hour day while the corresponding earnings for a saw operator at Sao Hill Sawmill Limited in 1977 was about T.Shs. 22 per day, and for casual labour about T.Shs. 14 per day (Exchange rate in 1977: 1 USD = T.Shs. 8).

In this analysis, the cost factors included were: (i) timber input cost (royalty fee or stumpage price); (ii) labour cost (sawing and timber transportation labour); (iii) cost of tools (investment and depreciation) and; (iv) cost of other inputs (fringe benefits to pitsawyers). Benefits were derived from timber sales hence were based on timber price. Timber production, its production cost and timber price at the nearest roadside were based on a survey of pitsawyers and field observation in the study area. Stumpage price and government sawn timber price were based on the 1993 new Forest (Amendment) Rules within the Forest Ordinance, CAP 389. Average royalty for five species (including all fees at various levels of authority) was 26000 T.Shs./m³. The species included were: *Milicia excelsa*, *Newtonia buchananii*, *Ocotea usambarensis*, *Entandophragma excelsa* and *Khaya nyasica*. Total labour cost was 34900 T.Shs./m³ of which T. Shs. 17500 were for sawn timber transportation cost to the nearest roadside and T.Shs. 17400 was average sawing cost for five main species presented with sawing cost (T.Shs./m³) in parenthesis: *Milicia excelsa* (22000), *Newtonia buchananii* 11000), *Ocotea usambarensis* (15000), *Entandophragma excelsa* (20000), *Khaya nyasica* (19000). The cost of tools was calculated as depreciation cost based on average productivity of 10 m³/year. Table 4.3 presents cost of pitsawing tools in the Nguru mountains.

Table 4.3. Cost of tools for pitsawing in the Nguru mountains

Tool	Purchase price (T.Shs.) ⁽¹⁾	Life span (years) ⁽²⁾	Depreciation/year (T.Shs./year) ⁽³⁾	Depreciation (T.Shs./m ³)
Large saw	23000	5	4600	460
Cross-cut saw	21500	5	4300	430
Axe	1350	5	270	27
Hoe	1700	2	850	85
Bush knife	1200	2	600	60
File	800	0	1000	100
Tape measure	1000	0	300	30
TOTAL				1192

Source: Own field data

Footnote:(1) Mid-1994 prices (Exchange rate: 1 USD = T.Shs. 520).

(2) 0 Implies written off when bought.

(3) Depreciation is based on straight line method of depreciation.

Other input costs were negligible because pitsawyers received no fringe benefits from employers such as uniforms, protective gear, medical care, transport and accommodation. Food was normally provided but its value was deductible from salary. In general, pitsawyers were found to do their work under harsh, miserable conditions. This can partly be gleaned by closely observing the photograph of Appendix 4 in Monela (1995a). Since this analysis was limited to the sawing operation and transportation of timber to the nearest roadside, costs beyond the nearest roadside were not considered. The gross total cost of pitsawing including timber input cost, labour cost, cost of tools and other input costs amounted to T.Shs. 62092 per m³. Skage & Næss (1994) who studied pitsawing in 5 villages in Morogoro District, estimated (gross total cost of pitsawing to be 61980 T.Shs./m³. As for pitsawing benefits, the average market timber price in Morogoro town was 106000 T.Shs./m³ (Kalebi pers. comm. 1994). Government price for which confiscated timber from illegal pitsawing is sold on the market was T.Shs./m³ 93500 (*ibid.*): Survey results in the Nguru mountains showed that timber price at the nearest roadside was T.Shs./m³ 75000 or T.Shs. 2500 per piece of 2"6"12' timber.

Table 4.4 presents cost-benefit analysis of pitsawing as observed in the Nguru mountains. Based on 1994 prices, pitsawing is a profitable enterprise for the pitsawing contractor. This has also been reported by Fergus *et al.* (1977), Klem (1978), Kijoti & White (1981), Butera & Klem (1983) and Skage & Næss (1994). The pitsawyers also realized a substantial income from this enterprise. Skage & Næss (1994) report that pitsawyer's income in Morogoro District was about T.shs. 14000 per month contributing 71% of their total income. However, this income is realized only periodically because pitsawing has often been a seasonal activity (Kalebi pers. comm. 1994). The profitability to the contractor, is however, a function of factors such as wage levels, royalty rates and price of timber on the market. Due to poor control of pitsawing, the Government of Tanzania, at end of 1992, banned pitsawing activities in catchment forests. Unless the ban is lifted, profits from this enterprise might no longer be realized at least legally. The new royalty rates introduced in 1993, raised drastically rates for preferred species as a way to increase the use of currently lesser preferred species and to reduce pressure on most popular and possibly threatened species. The move also aimed at controlling harvesting of hardwood and also to restrict the use of hardwood to high quality uses and in consequence to promote more use of softwood and plantation wood for general purposes (Kalebi pers. comm. 1994). Such policy aims to protect social interests of catchment forests. Average pitsawing productivity for pitsawyers studied in the Nguru mountains was estimated by field survey of several pitsawing crews. Under the prevailing working conditions, the average productivity was 0.1 m³ /manday.

According to Solberg (1988), Fergus *et al.* (1977) presents probably, the first published and realistic estimates in Tanzania of productivity, costs and benefits of pitsawing. The study was based on a very limited sample from sawing plantation softwood mainly *Pinus patula* logs at Sao Hill and Mbeya. Based on the performed time studies for 2-men crew, assuming 8 working hours per day, 250 working days per year and 40% sawnwood recovery percentage, Fergus *et al.* (1977) reported the average productivity of 0.18 m³/manday or 45 m³/year with considerably good quality and low investment costs relative to sawmilling. Kijoti & White (1981) reported a pitsawing study of *Grevillea robusta* in the Pare mountains of Tanzania. The time study-based average productivity for a normal 8 hour working day was 0.047 m³/manday. Average recovery

was 42% and the average cost of pitsawing hardwood was T.Shs. 897 per m³. The pitsawyer earned approximately T.Shs. 40 per day compared to T.Shs. 14 per day for casual labour (Exchange rate in 1981: 1 USD = T.Shs. 8). Sawing quality was good and better tool maintenance would have improved quality and quantity of output. The pitsawyers studied did not incline to steady regular work. The study also found that, in mountain rainforests, hand sawing is ecologically less destructive than mechanical methods. Other studies not based on time study have also been conducted in Tanzania. Klem (1978) estimated 0.1 m³/manday, Jaako Pöyry (1992) estimated 0.3 m³/manday. Some factors which influence this productivity include: species sawn, type of tools, climate, topography, operational set up, pitsawyer's experience and motivation. These vary from place to place. Economic viability of pitsawing enterprise relies partly on productivity levels and quality of timber produced.

Table 4.4. Results of cost-benefit analysis and productivity of pitsawing in the Nguru mountains

Item	Value ⁽¹⁾
Price of pitsawn timber at nearest roadside (T.Shs./m ³)	75000
Production costs (T.Shs./m ³)	62092
Profit (Price-Cost) T.Shs./m ³)	12908
Economic productivity (Price/Cost)	1.2
Average sawnwood productivity (m ³ /manday)	0.1

Source: Own field data.

Footnote:(1) Exchange rate is 1 USD = T.Shs. 520 as at mid-1994.

4.2.3.3 Biodiversity benefits through collection from the rainforest

The benefit of biodiversity in Tanzania can partly be inferred from a popular Kiswahili saying that "Misitu ni mali" which means "Forests are wealth". This is very relevant since forests play an important role in the daily life of indigenous rural communities such as those in the Nguru mountains. The species surveyed in the Nguru mountains display a diversity of properties which are of local benefit as attested by the range of uses recorded for various species as presented in Appendix 8. The tropical rainforest emerges as a beneficial resource with multiple uses indispensable for the livelihood and welfare of local communities. Thus it is perceived as a public resource with capacity to meet basic human needs and emergencies and provides income sources. Many plants in the forest have a range of properties with multipurpose uses not yet widely documented. Examples of such species with many local uses are *Vitex doniana* (*Verbenaceae*), *Parinari curatellifolia* (*Rosaceae*), *Strychnos spp* (*Loganiaceae*), *Faurea speciosa* (*Proteaceae*). These are used for fuel, timber, medicine, bee-forage, fruit, fibre and fodder. Some species have specific properties and uses such as *Combretum species* (*Combretaceae*) is most popular for fuelwood, *Protea chionantha var. divaricate* (*Proteaceae*) for bee forage, *Flacourtia indica* (*Flacourtiaceae*) and *Parinari curatellifolia* for edible fruits. *Randia taylorii* and *multidentia crassa* (*Rubiaceae*) for medicinal use. Species were also identified with wide local use as food

supplements. These range from fruits, seeds, nuts, gums, sap, roots, tubers, and mushroom as presented in Appendix 8. To illustrate the role of forest-based income sources to the local communities in the Nguru mountains, Table 4.5 presents the percentages of respondents who are engaged in various forest-based economic activities.

Table 4.5. Forest-based income sources: percent of participating households (n = 59).

Forest-based source of income	Percent of participating population
Pitsawing	20
Furniture making	10
Wood carving	5
Weaving (basket, mat, bamboo plaiting)	36
Pole and ropes for construction	15
Firewood for sale	20
Charcoal for sale	25

Source: Own field data

It can be gleaned that a substantial percent of respondents take part in each activity to generate their household income. The most widespread local use of woody biomass in the Nguru mountains is fuelwood and building poles. Nearly all households (97%) rely on fuelwood to meet domestic energy needs mainly cooking and heating. With present income levels, most households cannot afford alternative sources of energy. Survey results showed the following pattern of forest products use (Table 4.6). Main species for fuelwood are those which dry easily. However, such species are also very important as catchment species. They include: *Albizia spp*, *Ceiba pentandra*, *Trema orientalis*, *Allanblackia stuhlmanii*, *Caussipourea gummifera*, *Lasiathus spp*, *Begonia spp*, *Soriendeia spp*, *Erythrophleum spp*, *Diopsy spp*, *Cilcomophor parviflora*, *Raubevia spp*, *Harungana madagascariensis*, *Parkia filcoidea*, *Hagenia africana*, *Arundinaria alpina* among others.

In addition to firewood for domestic purposes such as heating and cooking, woody biomass energy is also used for small scale industries such as brick-making, local beer brewing, crops and food curing and drying, iron mongering and baking. All households obtain the wood from the surrounding woodlands and the rainforest. There is still some limited woody vegetation on the slopes outside the rainforest which provide about 22% of fuelwood. This is particularly harvested from around farm plots. Nonetheless, households especially those located close to the forest boundary, obtain most of the fuelwood and poles from the rainforest environs. In addition to

fuelwood and poles, a considerable amount of wood is used locally to make tool handles, wooden spoons, cups, pestles and mortars, and other local craft products. Most of the woody biomass for local use is produced and consumed within the confines of the village as a "free good" where monetary transactions are minimal and consequently much of it goes unrecorded (Mnzava 1980). An inventory of different species of local importance showed that the local people, make use of various species from the forest to meet their daily needs. Other important nontimber forest products are: the palm and coconut leaves for weaving and thatching, dyes, oil seeds, herbs for food and medicine, mushrooms, small game, latex such as bird lime, berries and nuts, and fruits and bark.

Table 4.6. Forest products harvesting and collection from the rainforest in the Nguru mountains (n = 59).

Forest product	Frequency	Percent of sampled households
Timber	7	12
Firewood	46	78
Poles	29	49
Medicinal herbs	3	5
Fruits and food other supplements	12	20
Other products	23	39

Source: Own field data

Local people enter the Forest Reserve not always in search of wood but simply to collect such non-timber forest products. Some areas that are considered inaccessible for timber harvesting are sometimes penetrated to collect non-timber forest products of local value. Local people in Tanzania realize that it is prohibited to harvest timber without license in the Forest Reserve but they also understand that the Law does permit the collection of non-timber forest products (Mnzava and Riihinen 1989). Several threats to the rainforest are the outcome of such activities. Typical examples are bushfires and temporary settlements built close to the areas where such products are abundant (Njana pers. comm. 1994).

4.2.3.4 Potential economic benefit of tropical rainforest biodiversity in the Nguru mountains

Besides the presently locally used species, there are a number of species in the Nguru mountains with good potential for commercial uses. The high endemism of plant species in the area and high possibilities to find new more species enhance the potential commercial benefit of biodiversity in the Nguru mountains. This potential has not been fully exploited due to limitations in knowledge and capital. However, conservation of biodiversity in this area may preserve this potential for future generations. The potential commercial uses of biodiversity are discussed under three main categories: (i) Horticultural benefit; (ii) Crop breeding programmes; (iii) Other commercial benefit

Horticultural benefit of endemic plants

Species with widest potential use are the African violet (*Saintpaulia species*) and the African primrose (*Streptocarpus species*). There are also several wild fruit producing plants consumed locally. These could also be used in horticultural programmes to improve supply to the local populace. As mentioned earlier fruit collection is one of the major plant species uses in the area.

Crop breeding benefit of endemic plants

Coffee (*Coffea species*), pepper and other spices are found naturally in the Nguru mountains. Out of the 40 species of coffee known worldwide, 19 are known to occur naturally in the forests of Tanzania including in the Nguru mountain rain forests. 9 of these are endemic. These indigenous natural strains have great potential for genetic improvement of commercial coffee varieties. Similarly the natural strains of pepper and other spices can in the future be valuable for breeding programs to raise new better varieties of these plants. Plant breeding programmes have high potential in this aspect to domesticate some of these wild species most of which are slow growing. With excessive exploitation due to population growth and increased demand useful trees are rapidly dwindling and availability of forest products may become difficult in the future. Hence cultivation of some of these products could be a feasible idea in food security.

Other plants with potential commercial benefit

In the Nguru mountains, *Allanblackia stuhlmanii* is the most widely known since it produces seeds with a high content of oil useable for soap and candle making as well as for cooking. Large quantities are produced each year but only a small fraction is collected for household consumption by local people. Substantial quantities are consumed by wild animals or fall off the tree and rot on the ground. Another known species for this purpose is *Trichilia emetica* whose fruits bear seed with same edible oil-producing quality. However, only small quantities are locally collected from the rain forest for domestic purposes. The collection of seed from such species is a harmless practice to conservation since it demands original forest trees, thus could actually be promoted to benefit the conservation of the natural forest and its biodiversity. There is this untapped potential to make cheap edible oil which could also be used for commercial purposes in soap and candle making. In the long term, the modest use of capital to process such products

could promote commercialization and the income obtained from sales as well as the value added through processing, could give fresh impetus to development without overburdening women who are at present, main collectors and processors. There are many other plants and plant products which are of potential importance as spices, medicines, resins, fruits, berries, vegetables, honey, roots, palm leaves, mushrooms, bamboo pipes and so forth. Most of these are presently used locally (Appendix 8). While some are scientifically known, some still need to be scientifically identified.

Uses of tropical rainforest fauna in the Nguru mountains

The presence of large mammals such as buffaloes, bush pigs and various monkeys and even leopards near cultivated areas, pose a threat to humans and livestock. These animals often destroy crops causing loss or decline of harvest. However, hunting of these animals provide meat for the rural populace. Among the hunted animals are rock hyrax, dik dik, bush pig, birds and antelope. A variety of arthropods mainly insects such as ants, grasshoppers, larvae, caterpillars etc. are seasonally collected for food.

4.2.4 Biodiversity loss in the tropical rainforest of the Nguru mountains

The study shows that villagers obtain forest products from the rainforest and also practice farming around the forest and in the buffer zone. Timber and pole harvesting and land clearing for agriculture both in buffer zone and in encroached areas in the forest cause decline and biodiversity loss. Harvesting of fuelwood by the local people often does not involve felling of live trees because dead dry wood is preferred to green wood. Consequently the damage to the forest ecosystem is rather limited and for this reason fuelwood extraction is not always a direct cause of deforestation or biodiversity loss. These processes are often generated as a by-product of the other activities. Ahlback (1992) makes a similar observation. So is the collection of many other products from the forest for local consumption.

However, exploitation of poles for building and fencing has severe impact on biological diversity of the forest in addition to causing forest degradation (Rodgers & Hall 1986). Harvesting of building poles is more destructive to the forest ecosystem because only selected prime specimens of straight, strong species such as *Strombosia species* (particularly *Strombosia scheffleri*) are taken out. In the long run, this may lead to a lower quality of growing stock and a depletion of the gene pool of the preferred species. The selection of some species often involves removal of future seed trees for high quality species which is detrimental to species diversity (Rodgers & Hall 1986, Norris 1990). The negative effects (including biodiversity loss) of harvesting by pitsawing have been discussed in Monela (1995a). The role of farming in biodiversity loss emanates from slash and burn technique of farm clearing under shifting cultivation. Survey results showed that about 9% percent of people still practice some form of shifting cultivation or still clear new land by slash and burn technique. Encroached areas of the rainforest get similar treatment. Expansion of farmland also chases animals away just like vegetation clearance. Land tenure system and land rights regime prevailing in the Nguru mountains also contribute to biodiversity loss. This is later discussed in Monela (1995b). It is important to mention that poor

land management in cultivated lands encourage invasion of new areas to compensate for fertility loss in poorly cultivated lands. The landuse problems in the Nguru mountains are discussed in Monela (1995a and 1995c).

4.3 Existing practices of forest control to protect the tropical rainforest in Nguru mountains

4.3.1 Personnel and logistics for forest control in the Nguru mountains

The success of forest control mechanisms depends on many factors. To understand the problems involved in management of catchment forests, which in consequence promote human interference into these forests, it is prudent to assess forest staff conditions, their working gear, forest utilization schemes and afforestation programmes for villages surrounding the catchment forests (Nsolomo & Chamshama 1990). Morogoro Region Catchment Forestry Project, funded by the Norwegian Agency for Development Cooperation NORAD), is responsible for catchment forests in the Nguru mountains. For the whole region there are two vehicles at the Project Headquarters in Morogoro town and two motor cycles one at Headquarters and another at Kilosa District. There are 22 catchment forest staff (Forest Officer to Forest Guard). Equipment improved drastically when NORAD took over the funding. At Project Headquarters, besides administrative facilities there is equipment for special forest operations such as fire suppression. Such equipment can be borrowed during such special tasks. All catchment forest staff are provided with uniforms and transport of some sort depending on rank and type of activities.

In the Nguru mountains staff conditions include 7 Forest Assistants and Forest Guards on regular employment. Among them there are 3 Forestry Certificate holders, and 4 Forest Guards with vocational training. Occasionally, local people are employed when there is an operation for a particular activity such as boundary demarcation or bush clearing. School children are sometimes mobilized especially during tree planting. Staff is provided with working gear in form of motorcycles, bicycles, uniforms, rain coats, machetes and other tools. Staff also get regular training to improve their performance. Evaluation of performance is through reports, word of mouth and surprise checks in the field. Since the inception of the Catchment Forest Project, there has been much improvement in performance due to increased and reliable funding and logistical support. However, staff deficiency for the whole region is still a problem hampering efficient management. Each staff in the region still looks after an average area of about 14216 ha of forest, situated up to about 20 km from his place of residence with about 42 km of boundary to patrol. This partly explains slow response to human impacts in the Forest Reserve. According to CFP (1994), the other main performance problems include: (a) Bureaucracy of the Tanzania Government Treasury in releasing NORAD funds to the project (b) Unstable and archaic policies and directives at Forest Divisional level (c) Policing the Forest Reserve is cumbersome and expensive, so is involvement of local people due to their poor understanding. (d) High demand for marketable timber while harvesting in the Forest Reserve has been banned. The new strategy is to strengthen involvement of local people. The main management challenges therefore are to embark on a comprehensive plan for community participation in forest management.

Villages surrounding the catchment Forest Reserves in the Nguru mountains still put heavy

dependency on catchment forests to meet their basic needs. They also still practice some form of shifting cultivation involving slash and burn technique of farm clearing. Moreover, no vigorous afforestation programmes have been practiced except for what can be referred to as traditional agroforestry involving retaining few trees on a farm or planting a few fruit and fencing trees on a farm or around homesteads. Such trees produce wood of negligible magnitude compared to the need to sustain wood demand of the villages. Moreover, energy conservation is till poor as people still use three-stone stoves. Metal stoves are rarely used. Energy conserving stoves are made in Morogoro town but have not reached the rural areas in the Nguru mountains mainly due to high price. These management attributes and socio-economic conditions prevalent in and around the Nguru mountain catchment forests contribute to problems faced in forest protection. Some empirical data showing human impacts in the catchment forests of Morogoro District including the Nguru mountains are presented in Table 4.7. In the present report main attention is given to control mechanisms used to contain human impacts in catchment forests in order to protect these forests and biodiversity.

Table 4.7. Human impacts (fire and encroachment) in Forest Reserves in Morogoro District for 1989-1993.

Year	Forest Reserve	Area/boundary encroached (ha and/or km)	Area affected by fire (ha/km)
1989	Uluguru North Mkindo Nguru South	54 ha 410 ha 16 km	1.5 ha - -
1990	Uluguru North Uluguru South Kitulanghalo Mindu	5 km 15 ha - -	5.5 ha - 127 ha 10 ha
1991	Mbogo Kanga Nguru South Uluguru North Uluguru South Mindu Kimboza	12 ha - - - - -	- 112 ha 15 ha 40 ha, 4 km 50 39 6.5
1992	Kitulanghalo	-	50 ha
1993	Nguru South Uluguru North	12 ha -	- 55 ha

Source: CFP (1994).

4.3.2 Institutional setup in the Tanzania Forest Sector and its limitations on forest protection in the Nguru mountains

The success of forest management and control of human activities that interfere with forest protection is very much dependent on the institutional set up that exist in the country and in the locality. This is so because the applicable rules, regulations, guidelines sanctions, incentives, policies and laws are influenced by the institutional framework that is in place. Randall (1987) defines an institution as everything that orders the relationship among individuals in society, including laws, constitutions, traditions, moral and ethical structure and "customary and accepted ways of doing things". From this definition, institutions define "rules of the game" and help to define the structure of incentives facing individuals. In Tanzania, one important institution responsible with forest management and control is the Forest Policy. In this context, Forest Policy refers to the document outlining goals and objectives as opposed to forest policies which refer to actual forest practice. In the general Tanzanian usage, the term "Forest Policy" tends to refer to that policy paper and less to the legal provisions containing certain forest policy means (Mnzava & Riihinen 1989). Forest Policy is an institution for forest preservation, control, development and management (*ibid.*). To be effective, the Forest Policy must be able to meet the demands set by today's situation. It must set long-term objectives for the Forest Sector, integrated in the general landuse policy and aiming at sustainable use of the forest resource, based on the multiple use model. Its formulation must be in close cooperation of all relevant interest groups (Panayotou & Ashton 1992). This is so because the objectives of sustained forest development have strong linkages with other sectors of the national economy. Besides the 1986 draft of a new Forest Policy which has not been endorsed by Parliament (Solberg *et al.* 1994), the 1953 Forest Policy document enacted in 1961, has been the main guidance for forest activities in Tanzania (TFAP 1989).

This policy paper advocates the preservation of forests in perpetuity for the benefit of society as a whole. The role of Government in taking care of the interests of society is emphasized. It also contains provisions for afforestation to preserve or improve local climates and water supplies and to stabilize land which is liable to deterioration. There are also objectives for financial returns, promotion of research and education in forestry and for increasing understanding of the values of forests and forestry among the people. However, it has been criticized for being no longer appropriate under present conditions of rapid population growth, increasing scarcity of land, increased forest products demand, environmental hazards and more economic activity (TFAP 1989). One major short fall from which even forests in the Nguru mountain have suffered from is that the objectives of preservation, control and management do not cover natural forests in public lands. This is so because the principles contained in the policy statement are operationalized in legally reserved forests only which account for 30 % or 13.4 million ha, of the estimated forest area in Tanzania, which is about 44 million ha (Mnzava & Riihinen 1989). Also in forest plantations which cover about 80000 ha (*ibid.*). This 30 % is the area actually affected by the forest rules, while public lands are also dealt with by the same legislative instrument, yet there is no possibility to take legal action against culprits as long as the land concerned is not gazetted.

This state of affairs leaves about 31 million ha of forest and woodland without legal protection. Yet the natural forests are being heavily utilized to satisfy household and industrial needs. For example, the annual allowable cut for natural forests is estimated at 25 million m³ (r) while, in 1985, the wood based energy consumption alone was equivalent to 43 million m³ (s). A more destructive agent, however, is shifting cultivation and clearing land for agriculture. The Government and its various services have little possibility of halting deforestation on 70 % of the forested areas in public lands as long as it remains ungazetted. This situation has caused depletion of forest resources on public lands hence forcing people to revert to protected forests as is the case in the Nguru mountains.

An attempt by the Government to eliminate this handicap was made in 1986 by drafting a new Forest Policy which extends the objective of preservation, development, control and management also to public natural forests (Kowero 1990). Public lands within the village boundaries would be managed taking into account the provisions of Villages and Ujamaa Villages Act of 1975. Other important forested public lands should be included into "controlled area" governed by appropriate legislation (*ibid.*). The interest of society in these lands arise from their importance in supplying firewood, timber for charcoal and in supporting livestock grazing, beekeeping etc. Besides outlining desirable government activities in primary forest activities, the 1986 Draft Policy, like the present Forest Policy, contains provisions for other public bodies and for private and collective sectors in forestry matters. Villages are encouraged to practice forestry by establishing communal woodlots or by private effort.

These provisions, however, are hardly effective, as there are little actual instruments to implement them. Other shortcomings of the 1953 Forest Policy are that the policy texts and its legislation are statements of general objectives rather than detailed guidelines on policy implementation. It is also unclear and unspecific in empowering the appropriate Ministry or the implementing Agency to issue more detailed guidelines for implementation. Furthermore there is missing emphasis on certain issues. For instance it does not specifically address certain landuse problems emanating from people's needs or customary practices. It overlooks the role of villages in producing fuelwood and in changing agricultural practices to the benefit of more rational landuse. Such shortcomings of the Forest Policy have had negative translation in natural forest management in public lands where forests have been depleted and people are now reverting to protected forests such as those in the Nguru mountains.

4.3.3 Legislation and law enforcement as a means of forest control in Tanzania

Forest legislation is defined in the context of the Forest Ordinance which is the major legal instrument for implementation of the Forest Policy. Thus protection of catchment forests depends and has been effected through laws and regulation contained in the prevailing Forest Ordinance of 1957. Besides dealing with creation and declaration of Forest Reserves, it deals with administration of rules that govern forest activities hence it is not meant to contain policy means in order to attain certain objectives. Although vague in aspects such as property rights regimes, standards for forest management and how to enforce them, it states sanctions in the Forest Reserves and associated penalties. It also defines incentives for sound forest practices. The

effectiveness of this legislation in protecting Forest Reserves has been hampered by improper enforcement. The immediate causes are lack or shortage of human and financial resources exacerbated by archaic laws, bribery among Forest Officers, and the present forest administrative set up operating with different chains of command (figure 4.1), and ignorant public which has developed negative attitude towards forests.

In Tanzania forests fall under two categories: protected and unprotected. Protected forests or Forest Reserves may be under the authority of Districts, Regions or Central Government (figure 4.1). Forests outside the Forest Reserves are standing on public land hence are subject to decisions of the village authorities. The reason for the Government to declare special Government forests in a country where all land is public and belongs to the Government is that, these Forest Reserves contain the most valuable forests of the country. Hence the aim of the Government is to establish and maintain different regimes of forest management within the Government according to the value of the resource (Fottland 1993).

However, the present administrative set up of the forest estate in which Forest Officers fall under three different authorities (i.e. District, Regional and Central Government, figure 4.1) does not guarantee best management of the values contained in the natural forests despite increased support from foreign donors. The experience indicate that the more local connection that are held by the managing authority, the more difficult it is to prevent the use of the forest land for other purposes and to prevent overutilization. Even if the intentions of the decision makers at any level may be the best, then the control and follow up in the field may be of different standard, thus not having the capacity to counteract bad practices in the forest. The fact that Reserved Trees, i.e. tree species of outstanding commercial value (Appendix 9) and thus rare are on public land and under the authority of Regions, creates problems in protecting such trees. The woodlands which largely lie outside Forest Reserves have in consequence suffered from degradation caused by human economic activities. There is hardly any closed forest - rainforest, mangrove etc - outside Forest Reserves due to high land pressure in public lands. Farmland has expanded to the Forest Reserve boundary. Thus it has been imperative to declare all closed forests as Forest Reserves. The evident clear demarcation line between Forest Reserve boundary and adjacent farmland is an indication of some success of the current management of the Forest Reserves as compared to the management of public land. This may be more luck than according to plan, however.

Past and present forest depletion in public land and the present threat in reserved forests is enough reason for anxiety. Assuming no change in Forest Policy and legislation, past trends of forest depletion are likely to continue or even accelerated. It is desirable therefore to update the Forest Policy and its accompanying ordinance to make law enforcement an effective tool. The 1986 Draft Policy proclaims most expected changes, including a proposal for a new administrative set up as shown in figure 4.2. One of the legislative tools for forest control is the use of licenses. In the next section licenses and the licensing procedure to control use of forest resources in the Nguru mountains is discussed.

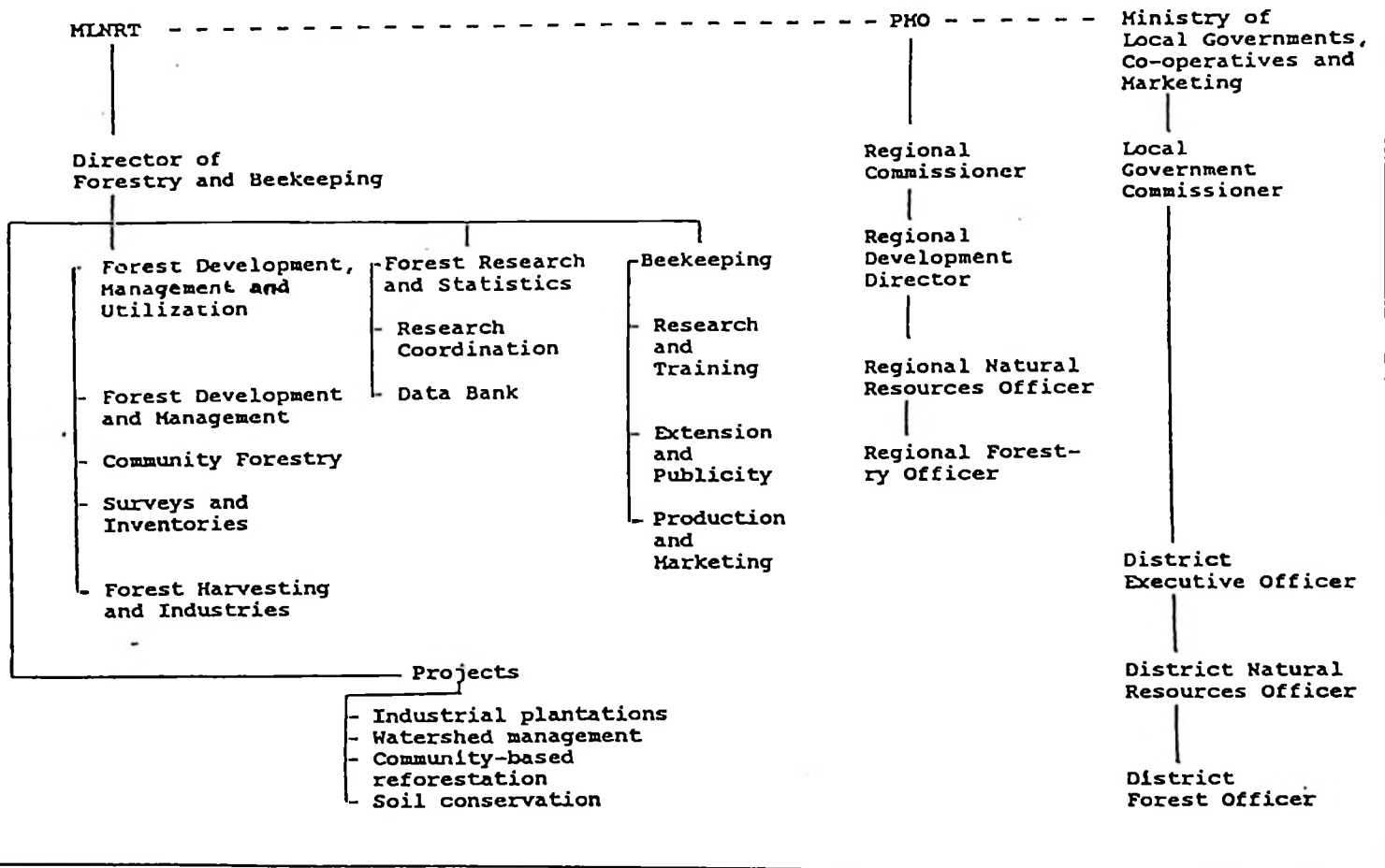

Figure 4.1. Public forest administration in Tanzania, operating with three chains of command to manage and control the same forest resource.
 Source: TFAP (1989), Technical Annex IX p. 29.

4.3.3.1 Forest laws and regulations enforcement in the Nguru mountains

Forest laws and regulations have for many years been a means used to control forest destruction. The usual practice in the area was to get the permit from the local forester if one wanted to harvest timber from the Forest Reserve. Also patrols were frequent. Foresters in the area and interviewees reported that the system worked well during the period to 1969 and there after, in the 1970s onwards, entry into the forest without permit increased sharply due to depletion of forest resources in public areas. The failure of local foresters to mount effective patrols and education has contributed to this situation. 59% of survey respondents reported that there are no patrols by forest guards, 7% percent have met forest guards on patrol whereas 34% did not know because patrolling is done secretly. About arrests in the forest 17% conceded to have seen someone arrested while 83% have not seen somebody arrested. The disappearance of vegetation and absence of timber size trees in the public lands point to the lack of measures to protect the natural forest in public lands. It can be suggested therefore that patrolling is very weak due to limitations of human and financial resources. The one Catchment Forester and 2 Local Authority Foresters situated in Turiani Division live more than 10 km from the nearest forest boundary. This allows illegal activity in the Forest Reserve to continue with impunity.

4.3.4 Licensing as a legislative tool for forest control in the Nguru mountains

In Tanzania, harvesting of timber and commercial exploitation of other forest produce is regulated through permits, licenses and timber sales agreements (TFAP 1989). Licensing forms a legal basis for forest activities in Central or Local Government owned-Forest Reserves and serves as a means of control. Issuing of licenses is done by the Director of Forestry (or any person authorized by him) with the exception of forests under village jurisdiction where local authorities may grant licenses. A license gives a buyer (holder) an exclusive right to utilize the forest product such as a tree for which the license is issued. The various forest activities requiring license are specified in Part VI of the Tanzania Forest Ordinance. Commercial utilization of forest resources as opposed to local consumption require a license. Pitsawing and charcoal making are typical forest activities that require a license. The importance of a good licensing system are threefold: (i) it guides the behaviour of forest users in accordance with forest management aims; (ii) ensures benefits to the local population; (iii) gives the owner revenue to continue with forest management operations. The immediate interest of license holders is to exploit the resources as efficiently as possible while the long-term interest remain with the Government. The crucial aspect is thus to what extent the owner's interests are guaranteed by the licensing system. Shortcomings may emanate from the issuing procedure, license contents or control functions. The presence of unarrested illegal pitsawing activities as Table 4.8 shows, may illustrate the shortcomings of licensing and associated weak law enforcement.

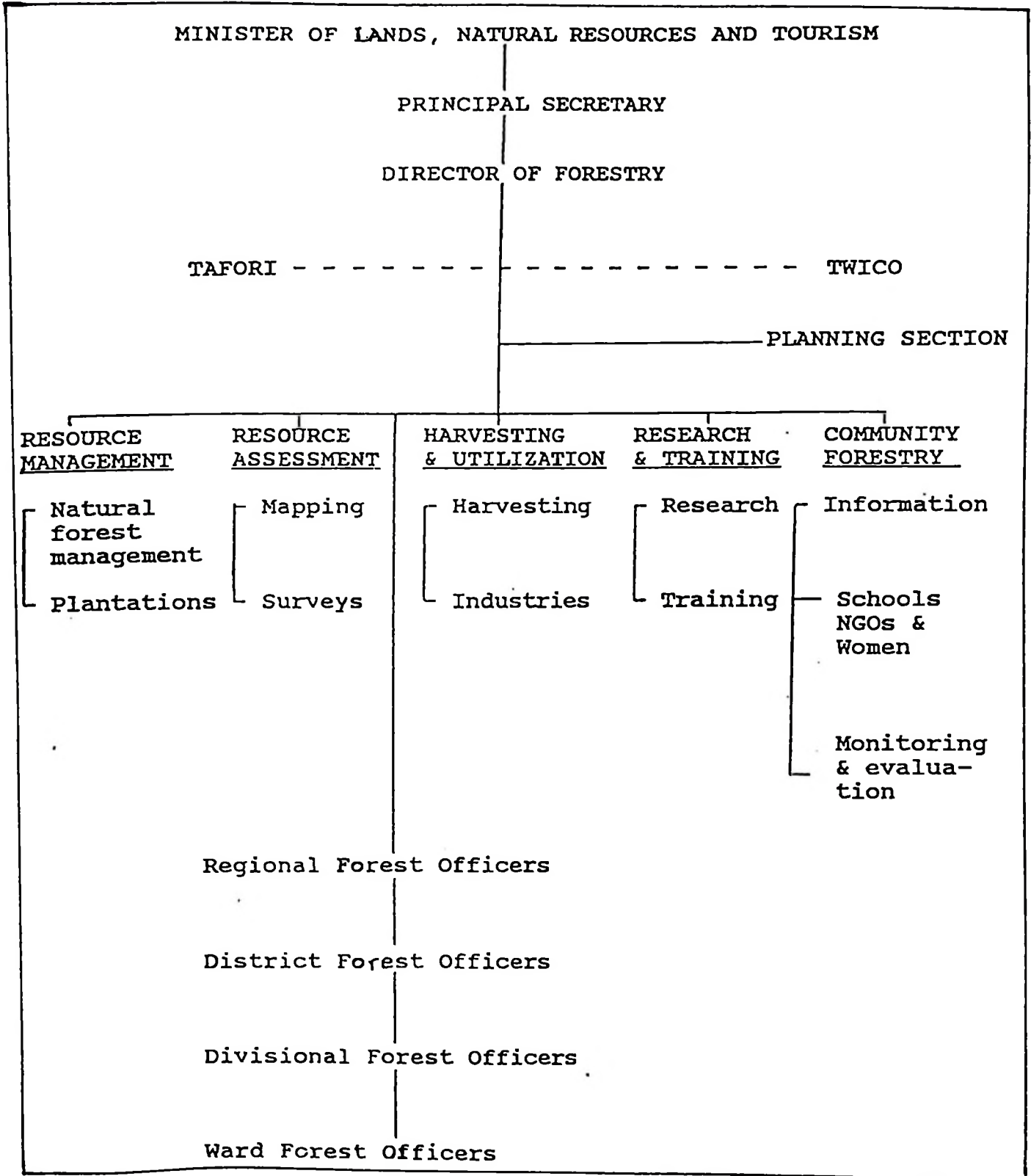

Figure 4.2. A proposed unified organogram for the Tanzania Division of Forestry.
 Source: TFAP (1989), Technical Annex IX p. 30.

Table 4.8. Licensed and illegal pitsawing in Nguru South Forest Reserve for the period 1989-1994.

Year	Number of licenses issued	Number of arrests due to illegal pitsawing	Number of unarrested illegal pitsawing activities
1989	36	nil	2
1990	8	2	3
1991	16	1	2
1992	22	2	3
1993	-	2	6
1994	-	nil	11
TOTAL	82	7	27

Source: CFP (1994).

In Tanzania, the principles in issuing and contents of a Forest License are in accordance with the rules in the Forest ordinance. However, differences exist due to locality, authority involved and nature of forest product harvested. The licensing procedure discussed here relates to Catchment Forest Reserves in the Nguru Mountains as practiced before the 1992 Government ban of timber harvesting activities in catchment forests. The aim is to give an insight of how licenses are used as a forest control tool for conservation and sustainable management purposes.

License issuing procedure and license contents

Stepwise, the issuing of license in the Nguru mountain catchment forests follows the following procedure: (i) applicant contacts the Forest Authority adjacent to the forest where he wants to operate. The local Forester normally represents the Catchment Forest Project Authority; (ii) the applicant and the local Forester visit the forest to reach agreement on which trees to fell within a demarcated area; (iii) the agreement papers are sent to the Regional Catchment Forestry Office in Morogoro for final approval and issuing of license.

The license has two parts: Part I is given before felling and lasts for 30 days. Harvesting without removal of the produce must be completed within this period. Part II also lasts for 30 days and involves measuring the produce to quantify it, pricing it and marking it for legality. The contents of Part I of the license are: date of issuing, name of license holder, area of exploitation, type of produce, advance payment and additional exploitation conditions. Since there is no public announcing of the license holders, the license holder is obliged to carry a copy of the license to be shown on request as proof of legal activity in the forest. Additional exploitation conditions are meant to safeguard social interests of forests such as prohibiting harvesting along riverbanks, steep terrain, cutting undersized trees or requirement to plant seedlings after harvesting is over. The contents of Part II of the license include: exact volume of produce, value to be paid, advance or down payment, identification marks and duration of the license.

License inspection procedure

Inspection to ensure adherence to the conditions of the license is carried out during operation in the forest. It also aims at ensuring that damage to the forest is properly compensated. Non-adherence to the conditions of the license may lead to confiscation of harvested produce, a fine or prison sentence. Under the prevailing laws, a fine for a first offence is T.Shs. 5000 or 6 months prison term. Fine for a second offence is T.Shs. 12000 or 12 months prison term (Exchange rate at mid-1994: 1 USD = T.Shs. 520). If offence is further repeated both fine and prison term can be imposed concurrently. These penalties may seem too low and archaic to cope with present conditions.

Effectiveness of licensing in the protection of the tropical rainforest in the Nguru mountains.

Due to the high demand for forest products under conditions of growing population and poverty, coupled with depleted forest resources in public lands, pressure on Forest Reserves has increased. Most license applications have been mainly from pitsawing Contractors. While some pitsawing Contractors buy licenses, a substantial pitsawing activity have been carried out illegally as Table 4.8 shows. Even those pitsawing Contractors who buy licenses often violate the conditions mainly through cutting more trees than permitted, cutting undersized trees, harvesting in restricted areas and ignoring proper tree felling directives. Besides the arrested culprits, several illegal pitsawyers have managed to fell trees, saw the timber and carry it away from the forest unnoticed. Unarrested illegal pitsawing activities have been monitored by local forest authorities through counting of pits left out after pitsawing is done. These unarrested cases of illegal pitsawing are shown in Table 4.8 for the period 1989 through 1994. Based on Table 4.8, licensed pitsawing in the Nguru South Forest Reserve, accounted for about 71 percent of total recorded pitsawing activities, arrests accounted for 6 percent of all pitsawing activities and unarrested pitsawing accounted for 23 percent of all pitsawing activities. Unarrested cases of illegal pitsawing account for about 79 percent of all illegal pitsawing. The driving force behind illegal pitsawing is to evade license costs in order to maximize profit, to evade bureaucracy in the licensing procedure or denial of license by forest authorities. For example, according to Kalebi (pers. comm. 1994) the Government harvesting ban in catchment forests has encouraged illegal pitsawing activities (Table 4.8). Also some foresters indulge in bribery during licensing. A local forester in Turiani Ward was sacked in 1992 for being an accomplice in an illegal timber harvesting racket in the Nguru South Forest Reserve (CFP 1994).

Problems identified in the licensing procedure include: (i) Conflict of interest between the forest authority and local interests; (ii) Lack of human and financial resources to monitor licensees in the forest; (iii) Long distances (geographical and administrative) from the decision maker to forest sites hence deterring community involvement in administration of harvesting; (iv) Inadequately detailed and vague license; (v) Incompatible number of trees available and number permitted in one locality. For example in 1992, a total of 400 trees were licensed for removal in Nguru South Forest Reserve. Since a great part of the forest is inaccessible most of these trees were removed in a limited area hence causing great impact and without replacement planting. If illegal harvesting is included, the impact is even further increased. So licensing, if unproperly

implemented as it is now, is not an effective means to control use of the forest in the Nguru mountains.

In general, forest control by licensing seems deficient due to failure of property rights regime, legislative shortcomings, insufficient information and lack of resources among other reasons. Rectifying these shortfalls and enhancing contact with local people around forests is imperative as observed also by Technical Annex VIII p. 14, TFAP (1989) in the following quotation: " there is a need to reform the license systems for timber and other products, as they are easily evaded for example by using an old license many times. Penalties are low. A centralization is an impediment to implementation of the license system".

4.3.5 Royalties and forest control in the Nguru mountains

Royalties in forestry are among the means used as control mechanisms to foster sustainable forest management by limiting the use of forest resources. Generally, royalties have the following functions in forest management. (i) To collect revenue from activities performed in the forest; (ii) As a means to give incentive to forest users for efficient resource use. Thus charging royalties is an economic approach to optimal exploitation of renewable resources including revenue collection and internalizing of external effects caused by forest users. The behaviour of forest users is governed also by the economic factor on which royalty is imputed on. This may be profit, timber input, timber output or whole tree. According to the Forestry Rules prevailing in Tanzania, royalties are set administratively without reflecting timber production costs and without direct mechanisms for adjusting the royalties to short-term market fluctuations. The tendency has been to undervalue the timber resource (i.e. below-cost timber sales) and in consequence, motivating increased forest resource exploitation. With royalties set low, often too low, the government has failed to collect enough revenue from the forest resource because there is also no adjustment by other means. While a licensee gets much revenue, the Government has been losing revenue and hence its ability to finance forest management has been curtailed, the other external effects of below-cost timber sales notwithstanding. The licensees have resorted to capturing resource rent to maximize profit at the expense of society. The cost to society besides loss in revenue includes degradation of the forest resource, mainly by pitsawyers. This situation, coupled with other factors, galvanized the Government decision to ban licensed harvesting in its catchment forests while reviewing future harvesting policy.

In December 1993, the Government published, in Government Notice # 265, new royalty rates which brought a drastic increase in fees for popular high quality hardwoods. The aim being to restrict their use, to control harvesting, and to encourage use of softwood and plantation timber. This also aimed at adjusting royalties to market value of the timber resource and hence to allocate forest resources more efficiently. The old royalty rates (Table 4.9) and new royalty rates with percent increase over old rates (Table 4.10) are presented for illustration. The definition of classes is presented in Appendix 7A for old royalties and Appendix 7B for new royalties. It can be gleaned that for timber, highest increases in royalty rates are for highest class species while for other products they are for highly demanded forest products.

Table 4.9. Old 1992 royalty rates for natural forest popular hardwoods and other forest products, where the produce is cut and removed by the licensee.

Timber/produce category	Royalty ⁽¹⁾ in T.Shs. per unit specified in the remarks column	Units and remarks ⁽²⁾
Class I	13800	m ³
Class II	4600	m ³
Class III	3120	m ³
Class IV	2100	m ³
Class V	1600	m ³
Class VI	1050	m ³
Poles (15-20 cm)	30	Each
Withies (<5 cm)	50	per load or < 50
Firewood (quantity license)	200	per stacked m ³
Firewood (time license)	500	per headload
Charcoal	100	per 28 kg bag
Raffia fibre (quantity license)	600	per 1000 kg
Tree seeds	-	-
Seedlings (non-ornamental)		
(i) Potted	50	per plant
(ii) Unpotted	-	-
Seedlings (ornamental & fruit)		
(i) Potted	100	per plant
(ii) Unpotted	-	-
Bamboo (<5 cm)	10	per meter
Bamboo (>5 cm)	8	per meter
Gums and resins	100	per kg
Other forest produce	500	per month

Source: MTNRE (1992), Government Notice # 251.

Footnote: (1) - means not available

(2) 1 USD = T.shs. 520 (as at mid-1994)

Panayotou & Ashton (1992) observe that underutilization of the tropical forest resources is a severe problem both due to lack of enforcement and also as a result of too low royalties. Repetto & Gillis (1988) observe that, while 80% of the tropical forests are state owned, only about 10-15% of the value of these resources is captured by Governments. Undervaluing the resource may make other potential uses of the forest land to gain at the expense of forest uses because Governments, as forest owner, may have to choose between keeping the forest intact or use the land for other purposes. This situation once happened in the Usambara mountains where, under political pressure to meet local political aims, large tracts of forest land were cleared in the 1960s to give room for agriculture and settlements and in consequence causing severe land degradation

(Kalaghe *et al.* 1988). However, setting too high royalties as is the case with the new royalty rates may sometimes also be undesirable because if law enforcement is properly effected, it may wipe out private profitability of forest users. But if regulations are left loose as at present in the Nguru mountains, too high royalty rates may lead to increased illegal harvesting, calling for more patrolling and other control mechanisms which increases Government financial burden. For a long time in Tanzania, setting low royalty rates has been a common practice, its demerits notwithstanding. The fact that royalties are set per unit volume of roundwood has partly compelled users to use the log more efficiently. However, setting royalties per tree would encourage the use of even other parts of a tree currently unused such as branches, lower trunk, leaves etc. One handicap would be differentiating tree sizes and qualities. The disadvantage is more Government spending in administration resources.

Table 4.10. New 1993 royalty rates for natural forest popular hardwoods and other forest products, where the produce is cut and removed by the licensee.

Timber/produce category	Royalty ⁽¹⁾ in T.Shs. per unit specified in the remarks column	Percent ⁽²⁾ increase over old rates	Units and Remarks
Class I A	50000	262	m ³
Class I B	20000	45	m ³
Class II A	10000	117	m ³
Class II B	7000	52	m ³
Class III	5000	60	m ³
Class IV	4000	90	m ³
Class V	2000	25	m ³
Poles (5-10 cm)	50	67	Each
Poles (>10 cm)	80	167	Each
Withies (<5 cm)	150	200	per load of 30
Firewood (quantity license)	1000	400	per stacked m ³
Firewood (time license)	600	20	per month
Charcoal	200	100	per 28 kg bag
Raffia fibres (time license)	1200	100	per month
Raffia fibre (quantity license)	2000	233	per 1000 kg
Other fibre	500	-	per 1000 kg
Tree seeds	200	-	per kg
Seedlings (non-ornamental)			
(i) Potted	60	20	per plant
(ii) Unpotted	40	-	per plant
Seedlings (ornamental & fruit)			
(i) Potted	200	100	per plant
(ii) Unpotted	150	-	per plant
Bamboo (<5 cm)	300	-	per 20
Bamboo (>5 cm)	500	-	per 20
Gums and resins	100	0	per kg
Other forest produce	1000	100	per month

Source: MTNRE (1993), Government Notice # 265.

Footnote: (1) 1 USD = T.Shs. 520 (as at mid-1994)

(2) - means not calculated due to incompatible units or the product category was absent in the old classification.

4.3.6 Property rights regime and forest protection in the Nguru mountains

Property rights have a strong bearing in securing forest control. Forest property rights on the other hand are dependent on forest ownership patterns that exist in the area. The existing forest property rights in Tanzania and in the Nguru mountains are such that the Government is the major forest and land owner. What is referred to as public land in fact belongs to the Government because according to the Land Ordinance all land belongs to the State (Government) which can allocate it to various users. In the Nguru mountains the remaining forests are Government protected under Forest Reserves shown in Table 4.11 of which, 33005 ha are in the eastern slopes and 28242 ha in the western slopes (Mitzlaff 1991). The rest of the land in the area is public land under jurisdiction of villages according to the 1975 Villages and Ujamaa Villages Act. Government owned Mtibwa Sugar Estates Company Limited on the Wami river plains East of the mountains and Mtibwa Teak Plantations North of the sugar estates occupy some land on the flood plains of the Wami river. Village forestry and private forestry are negligible in the area inspite of Government encouragement. However, various forest and land users are interested in trees and land in various ways which make the issue of property rights regime crucial in forest protection. Under the existing forest ownership and property rights, conflict between social and individual rights is inevitable. While in the Government's view, social interests override individual interests in protected forests, individuals crave more for fulfillment of their needs. However, the principles of forest utilization are the same regardless of choice of property rights regime. While the Government aims to safeguard social interests, individuals are compelled to exploit the forests especially because their needs can no longer be met from forests and woodlands in unreserved public lands.

Based on the existing property rights in Forest Reserves, the owner (Government), has strong incentive for efficient resource utilization because failure to do so would jeopardize social interests due to the evident threat caused by people's quest to satisfy their private basic needs or maximizing profit. Restriction by the Government is implemented by various means which include taxes, royalties, bans and patrols. However, the results have been poor. The biggest constraint causing forests destruction within today's property rights regime is Government's failure to enforce its property rights in protected forests. Due to many factors (such as breakdown of traditional management systems and power structures at local level, inadequate legislation, lack of resources to enforce laws and high forest product demand), the Government has failed to enforce forest laws thus indirectly allowing people to use forests illegally. One shortfall in the existing legislation for forest practices in relation to property rights is lack of specification of access to forest resources. It does not specify who can, and who cannot access protected forest resources. Free access provides cover to culprits disguising as mere visitors in the forest. Moreover, the mere presence in the forest sometimes prompts people to carry out some activities including illegal ones. Existing forest legislation fails to deal with landuses which conflict with forest interests. This has created uncertainty about future ownership, thus removing incentives for individuals to invest or practice sound long-term forestry. Lack of clear specification of property rights in protected forests, lack of law enforcement, general uncertainty about future ownership and increasing population pressure on scarce resources have culminated into "open access" situation whose consequences have included forest resource degradation and loss of profit

and biodiversity. The existing state ownership of forests in the Nguru mountains may be challenged for its inability to enforce regulations, inefficient management and administration, and shortage of information. However, in view of social interests, it is still useful that the rainforest remains in Government hands but with rectification of management shortcomings. As Sharma (1992) notes, Governments have better ability of managing forests with the long-term national interest in view, together with the most access to the expertise necessary to plan and control long-term landuse.

Table 4.11. Forest Reserves in the Nguru mountains

Mountain Range	Forest Reserve	Area (ha)
Nguru South	Nguru South	18800
	Kanga	6664
	Mkindo	7541
Nguru North	Kwediboma	285
	Mkongo	985
	North Nguru	14042
	Kilindi	4641
	Derema	3928
	Pumula	1062
	Mbwegere	368
TOTAL	Mkuli	2931
		61247

Source: Mitzlaff (1991).

4.3.7 Community participation in forest protection in the Nguru mountains

The purpose of community involvement or participation is to reverse the attitude whereby villagers or local communities have always perceived a Forester as a "policeman" due to the role he has played in forest protection based on forest law enforcement. This approach has portrayed a Forester as an enemy of the local community and as such anything a forester has suggested, has been looked upon negatively with suspicion or skepticism. A Forester has also been perceived as corrupt, the situation also observed by Fottland (1993). Westoby (1975) observed that: "Foresters should understand that their profession is to serve people, not trees". In consequence, involving local communities in forest management has been underlined as an important strategy to achieve forest and biodiversity protection (WRI, IUCN & UNEP 1992; Wells & Brandon 1993). However, this relies upon the compatibility of forest management with local interests (ITTO 1990). In forest management, there are many actions which do not give immediate benefit

to local communities and sometimes may temporarily or permanently, restrict or deny them access to the forest resources. Declaration of Forest Reserves is one such action due to restrictions which go with it. Such actions must be motivated in the interest of conservation. Illegal extraction from the forest is against forest rules, yet local people would wish to do it to reap private benefits.

In the Nguru mountains forest extension is still limited by distance between the scattered villages, poor infrastructure, lack of transport and poor communication. The importance of providing local people with a good share of direct benefits from the forest and involving them in management has been recognized by forest authorities as informal discussions with Forest Officers managing forests in the Nguru mountains indicated. However, lack of implementation have resulted in conflict between private and social rationality, thus resulting into forest degradation. The forest authorities deal more with social interests than local needs and the situation is worsened by politically weak local interests which cannot compete with Government priorities. The local people with their high discount rate in the quest to meet basic needs, have therefore developed ambivalent behaviour towards rainforest exploitation.

Survey in the Nguru mountains indicated that, forest laws and regulation are the major means used by Foresters to control the use of the forest. Community involvement has not been fully used. In consequence, a big segment of the local public has remained ignorant on the long-term benefits of protecting the rainforest in their vicinity. To get an impression of villager's involvement in protecting the natural forest, 59 households were interviewed about how much they were aware about the role of the buffer zone in protection of the Forest Reserve. The responses are presented in Table 4.12. The table illustrates that villagers do not recognize the buffer zone as an area meant to cushion the protected core forest area, since no one mentioned this role. This has led to intensive use of this area, causing immense degradation and leaving the Forest Reserve as an isolated island in the landscape. This intensive use has overspilled into the protected rainforest core zone. Overuse of the buffer zone to the point of threatening the Forest Reserve partly shows how people are unaware of the importance of the buffer zone for forest protection. Land hunger and several other existing landuse incentives promote forest degradation in the Nguru mountains. Presently for instance, the existing land tenure rights give an individual who clears land for agriculture, use rights (under Rights of Occupancy) for the land he has cleared. This is an incentive to clear forests in public lands and has been operating against forest conservation objectives. Such condition has been promoted by poverty because forest lands with "open access" have acted as "resources for last resort" for poor rural people in the Nguru mountains. With such lands diminishing, people have been compelled to revert to protected forest areas to meet their basic needs hence complicating forest control activities.

Table 4.12. Responses to show farmer's awareness about buffer zone functions (n = 59)

Uses of the buffer zone area	Frequency	Percent
Is where many people cultivate	34	58
Is a place we obtain poles and ropes	45	76
Is where we collect firewood	46	78
Is where we get timber	5	9

Source: Own field data

4.3.8 Cost-benefit approach to control illegal pitsawing in the Nguru mountains

Illegal pitsawing activity is one of main activities taking place in the Nguru mountains with the effect of degrading the rainforest and its biodiversity. The negative impacts of both legal and illegal pitsawing to the forest owner are presented in Monela (1995a) and in section 4.3.4. of the present report. Table 4.8 indicates that illegal and legal pitsawing are taking place side by side. Normatively, illegal pitsawing is unacceptable and should be wiped out because it threatens biodiversity. However, under the prevailing conditions in the Nguru mountains, possibilities of wiping it out are minimal (Njana pers. comm. 1994). The costs of monitoring and policing prevent forest authorities from successful enforcement of property rights and in consequence the forest is not used exclusively for the allocated purposes. Thus, illegal pitsawing has flourished. Illegal pitsawing will continue if its rate of return is higher than the alternative rate of return available to the illegal pitsawyers. That alternative rate of return may, for example, be waged labour (Pearce and Moran 1994). Since illegal pitsawyers run risks of apprehension and punishment, it is reasonable to suppose that illegal pitsawing will be pursued as long as the return from illegal pitsawing exceeds the alternative wage rate plus a cost of the risk of being apprehended. In this sense, illegal pitsawing must be seen as an economic activity. In a positive approach and based on cost-benefit analysis, illegal pitsawing can be analyzed in light of the primary forest management aim, which is maximization of net present social value of the use of forest lands. In this context, both benefits and costs of illegal pitsawing are included in the social accounting of forest management. The critical factors to control illegal pitsawing in the Nguru mountains can be identified through a model expressed in equation [4.1]. The main assumptions of this model are: (i) Open access; (ii) Rational behaviour of illegal pitsawyers; (iii) Management aims to maximize both legal and illegal total social surplus; (iv) Forest removals are equal to growth (increment). From economic theory, profit of illegal pitsawing is a function of quantity of pitsawn timber, timber prices, harvesting costs, cost of evading forest officers and expected value of fine payments if apprehended (Hofstad 1992). Mathematically this can be expressed as:

$$\pi = \sigma(C_i) - A \cdot C_i - \mu \cdot C_i \cdot D(A, N) \quad [4.1]$$

where,

π = immediate profit of illegal pitsawyers

C_i = volume of illegal harvest

$\sigma(C_i)$ = gross payment from sale of illegally pitsawn timber

N = control activity

A = cost of avoiding forest authorities per volume unit

μ = fine per volume unit apprehended

$D(A,N)$ = probability of detection per volume unit which is a function of A and N .

In this model, illegal pitsawing is motivated by expectations of positive net income. This implies that, illegal pitsawing will be done as long as it is profitable for each pitsawyer, i.e until $\pi = 0$. Moreover, raising fines or increasing efforts for forest control activity is equivalent to making use of economic incentives for reduction of illegal pitsawing. Based on assumptions similar to those in model [4.1], Milner-Gulland & Leader-Williams (1992), developed an alternative model [equation 4.2] which was adapted and used in the present study to calculate the net revenue from pitsawing taking into account both the costs and benefits of illegal pitsawing. The model is:

$$NR = P/e - C - p * F - p(P) \quad [4.2]$$

where,

NR = price of timber

e = probability of finding a suitable tree for pitsawing

p = probability of being caught

C = cost of illegal pitsawing

F = the total fine.

For illegal pitsawyers in the Nguru mountains, the chances of being caught were estimated to be 0.03. Field surveys in the Nguru mountains indicated that illegal pitsawing has flourished in the Nguru mountains due to poor patrolling and too low penalties for apprehended culprits as presented in Table 4.13. Most apprehended illegal pitsawyers fail to pay fines which are relatively low, T.Shs. 5 000 for first offence and T.Shs. 12 000 for second offence according to the existing legislation (CFP 1994). Based on results of cost benefit analysis in section 4.2.3.2 and using the prevailing highest fine of T.Shs. 12000 for the second offence, the net revenue (NR) in T.Shs. per cubic metre using equation [4.2] is:

$$NR = 75000/0.8 - 62092 - 0.03(12000) - 0.03(75000) = 29048.$$

Given the fines, the probability of being caught, the revenues from timber, and the costs of pitsawing, it pays illegal pitsawyers handsomely to engage in this activity since the net revenue is positive and higher than the alternative rate of return from wage labour. The average time to produce one m^3 of pitsawn timber in the Nguru mountains is 12 mandays. Based on the prevailing (1994) minimum salary in Tanzania, 12 mandays are equivalent to T.Shs. 7000 which is lower than T.Shs. 29048 per m^3 , the net revenue from illegal pitsawing. Thus illegal pitsawing is likely to continue because its rate of return is higher than the alternative rate of return available in off-farm activities. From a social point of view, the income from pitsawing produce, is socially valued output, whether it is legal or not because consumers do not differentiate between legally and illegally pitsawn timber.

The social cost factors for illegal pitsawing are patrolling activity and the efforts used by the pitsawyers to avoid being caught (avoidance cost) which include, for example, pit-sawing in night time, finding inaccessible areas and bribing Forest Officers. All these techniques were reported to be practiced in rainforests of the Nguru mountains (Kalebi, Njana & Torstad pers. comm. 1994). Reducing illegal pitsawing activity is only beneficial when gains of reducing it exceed the

costs. Consequently higher fines to the extent of reducing pitsawing profit to less than zero while making the cost of evading Forest Officers higher are plausible. Furthermore, charging fines on the basis of volume apprehended is also rational compared to the current practice of flat rate fines.

Table 4.13. Penalties imposed on apprehended illegal pitsawyers in Nguru South Forest Reserves during the period 1989-1994.

Year	Number of arrests	Action taken against culprits
1989	nil	nil
1990	2	jailed 6 months
1991	1	culprit escaped
1992	2	culprit escaped
1993	2	culprit escaped
1994	nil	nil
TOTAL	7	

Source: CFP (1994).

The best approach is to maintain fines above running timber prices by regularly adjusting them to always reflect this situation. In Tanzanian condition this is not easy because fines are centrally determined and often, after a long period. Patrolling is also curtailed by limited resources both financial and human as well as the elusive nature of the pitsawyers. The Forest Ordinance, the legislation upon which catchment Forest Rules of the day originate was enacted in 1957 and has not been reviewed eversince. So like the Forest Policy, it is archaic. The effects of illegal pitsawing on distribution of benefits are also negative for the forest management. In an open access situation (which illegal pitsawyers often assume), the illegal pitsawyers have no incentive for long-term planning or sustainable management as the destruction they cause clearly indicate. At the same time, the resource owner (the Government), has failed to properly collect revenues which are essential for forest management activities or could give incentive for safeguarding the forest resource. Similarly, money collected from fines have normally not been available to the forest authorities responsible for managing the forests. This has also caused adverse effects on forest management. Under existing rules in Tanzania, money collected from fines, directly goes into the Central Government coffers and nothing directly goes to the forests where the offence was committed. Such a policy have contributed to insufficient funds to manage the forest resources. The same argument can be applied to other commercially exploited forest products. Due to lack of sufficient reliable criminal statistics and market information at project level, it was not possible, based on equation [4.1], to carry out an analysis of the behaviour of illegal pitsawyers, optimal harvest levels and patrolling policies in the Nguru mountains.

4.3.9 Economic incentive for forest control in the Nguru mountains

Economic incentives constitute a powerful tool for forest management and when absent may lead to deterioration of forest management. Economic factors upon which economic incentives depend are among the main driving forces in shaping the way forest lands are used. In this context, the term economic incentive involves money or factors that provide a living for the rural people. Cost-benefit analysis of pitsawing conducted earlier in the present report indicated that pitsawing is profitable for the pitsawing Contractor. Moreover, a substantial amount of income trickles down to the pitsawyers. These results are sufficient incentive for pitsawing activity to continue in the Nguru mountains. Likewise the benefits of collecting from the forest are substantial as shown earlier in the present report and in Monela (1995a).

However, a judgement of the social profitability of pitsawing and collection from the forest requires a more thorough analysis including all social costs and benefits generated by these activities. Most activities in the forest have externalities which lead to divergence between private and social costs. The externalities include forest degradation, increased cost of patrolling, cost of legal proceedings against arrested culprits, costs of fire suppression, encroachment etc. Thus a balance has to be struck between private and social profit in the Nguru mountains for the sake of sustainable management and forest protection. The prevailing situation indicate that externalities of human activities in the forest exceed benefits to the forest owner hence causing forest degradation.

4.3.10 Role of buffer zone in forest protection in the Nguru mountains

Type and extent of the buffer zone in the study area

In this study, the buffer zone is defined as the area between the Forest Reserve and the village which was earlier deliberately set (during establishment of the Forest Reserve), to provide extra protection to the Forest Reserve against direct human impacts. The buffer zone established by planting some few rows of exotic trees along the Forest Reserve boundary and forming part of the Forest Reserve, is negligible. The main focus therefore, is on the other type of buffer zone as defined above due to its importance in forest control in the Nguru mountains. A survey in the area plus information given by villagers and forest authorities showed that the buffer zone is about 3 km wide from the Forest Reserve boundary to the village. However, the survey showed that the buffer zone *per se*, in its real meaning is no longer existing because it has been cleared for farming activities with only patches of trees left in few places, and most of such areas are those not suitable for farming either due to the presence of rocks or because they are inaccessible. People can now easily come into contact with the Forest Reserve. Responses of interviewees indicated that 61% of respondents cultivate in the buffer zone.

Landuse in the buffer zone

Land in the buffer zone has been cleared using a common technique of slash-and-burn also renowned for its destruction of vegetation cover. The land such cleared is cultivated without

practicing soil erosion control measures. Neither have villagers planted trees in the buffer zone area. Before crop planting and after harvesting most of the land is left bare and exposed to soil erosion whose effect is to further deteriorate the land. The commonly used cropping system is mixed cropping of cereals, legumes and some fruit trees. The stream banks due to their proximity to water and high fertility, are intensively cultivated to the margin of the river to raise vegetables and banana, particularly during the dry season and in the absence of soil erosion measures, they are very prone to soil erosion. Vegetables and banana have a good local market in the area.

To check if villagers were observing the repercussions of damaging stream banks, gardens belonging to households sampled for the survey and located along stream banks were visited and distances from the water course in a stream to the garden boundary were measured. Table 4.14 presents data for distances measured and frequency of households for each distance. Most sampled households cultivate to the stream edge. It seems many do not care in their bid to maximize use of fertile alluvial soils and water. Diminishing availability of fresh land in the buffer zone may also be a contributing factor. Due to the high need to expand farmholdings people invade steep hills, stream banks and the Forest Reserve by encroaching its boundary. Moreover, they carry out other illegal activities inside the Forest Reserve. Illegal pitsawing being one such activity.

Table 4.14. Distance of farms from the river course (n = 59)

Distance from farm boundary to river margin (m)	Frequency	Percent of households
0	19	32
1-5	7	12
6-10	5	9
11-15	6	10
16-20	4	7
21-25	3	5
26-30	3	5
31-35	5	9
36-40	1	2
41-50	6	10

Source: Own field data

According to the widely accepted prevailing buffer zone management regulations, the activities envisioned for the buffer zones include: hunting or fishing using traditional methods, collecting fallen timber, harvesting fruit, seasonal grazing of domestic stock, and cutting bamboo, rattan, or grasses (Wells & Brandon 1993). Activities forbidden in buffer zones include: to burn vegetation, cutting live trees or constructing buildings and establishing plantations (*ibid.*). However, in the study area villagers have attacked the buffer zone area and are practicing all these prohibited activities. At present large portions of the buffer zone are occupied by farms and live trees are cut for various uses. This situation reflects the absence of control in the buffer zone

area. Respondents indicated that some important reasons for cultivating in the buffer zone are: Scarcity of land elsewhere (15%), fertility of land adjacent to the Forest Reserve (61%) and inherited land located in the buffer zone (7%).

Effectiveness of the buffer zone in the protection of the tropical rainforest in the Nguru mountains

The extent of activities taking place in the buffer zone as indicated by intensive use of the land to the extent of spilling over into the Forest Reserve, suggests that the buffer zone area has not achieved its purpose. Besides high demand for forest products and land hunger, this situation can be partly attributed to forest authorities neglecting the role of the buffer zone in protecting the Forest Reserve. By allowing uncontrolled use of land in the vicinity of the Forest Reserve boundaries, the forest authorities seem to indirectly invite the negative impacts on the Forest Reserve and its boundary. By clearing the land in the buffer zone, villagers have isolated the Forest Reserve and exposed it to direct human impacts. Another impact have been the drying up of some streams as they pass in the buffer zone area. The microclimate in this area is also different from that in the adjacent Forest Reserve where it is cooler and wet. About 57% of respondents conceded that they have noticed big changes in microclimate before and after intensive use of the buffer zone area.

Due to poor control in the buffer zone, some cultivated plots are as close as 50 m to the Forest Reserve boundary hence posing danger from encroachment and bushfires. To check villagers awareness of basic rules and regulations governing the Forest Reserve, they were asked to specify what they know of these regulations. Their responses are presented in Table 4.15. While a good number seem to be aware, a good number also seem to be unaware. However, both the aware and unaware do not seem to respect the rules particularly when it comes to fulfillment of their basic needs. In conclusion, the buffer zone seem to have failed in saving the purpose for which it was intended to save. Instead of protecting the Forest Reserve by inhibiting direct human impact, enlarging the effective area of the natural forest and reducing species loss through edge effect, it has been degraded severely.

Table 4.15. Responses to show villager's awareness on the basic rules and regulations governing the use of the forest reserve (n = 59).

Villager's response	Frequency	Percent
Not allowed to enter Forest Reserve	6	10
Not allowed to farm inside the Forest Reserve	9	15
Respect Forest Reserve boundary	16	27
Not allowed to cut trees inside the Forest Reserve	1	2
Allowed to collect nontimber forest products	8	14
Do not know Forest Reserve regulations	19	32

Source: Own field data

4.3.11 Recent approach practiced to enforce rainforest control in the Nguru mountains

Under the Catchment Forest Project discussed in Monela (1995a), several activities listed below are now under implementation together with "policing" to foster more efficient forest control of catchment forests and to protect biodiversity in the nguru mountains. These are as follows:

- (a) Resurveying the Forest Reserve and making maps to indicate more clearly the location and boundaries
- (b) Demarcation of Forest Reserve boundaries by planting rows of fast growing exotic tree species
- (d) Preparation of Management plans in order to improve management of catchment forests,
- (e) Eliciting or bolstering people's involvement in forest management activities (Community Participation Programme).
- (f) Training of Field staff
- (g) Forest extension work in villages adjacent to the catchment forests
- (h) Running tree-nurseries to raise seedlings for supplying villagers in the bid to promote establishment of village woodlots for supplying wood to meet local needs.
- (i) Planting in gaps inside catchment forests to enhance biodiversity through restocking of threatened species.

With regard to the achievements in the implementation of these activities, these are reported in Monela (1995a).

5.0 CONCLUSIONS AND RECOMMENDATIONS

This study has underlined the biodiversity importance of the tropical rainforest in Nguru mountains. The high number of species and presence of many endemic species gives an indication of species richness as one important dimension of rainforest biodiversity. Most likely this prevailing species richness of the rainforest in this area has high value to the scientific community and also has high potential for future economic utilization in Tanzania and beyond. At present local communities in the area make use of numerous indigenous species for various purposes: economic, social, cultural and political. Both timber and a variety of nontimber forest products for local consumption are exploited. Some species have multiple uses with potential for commercial use. Though previously unmonitored and unevaluated, the value of these products is high and their contribution to people's livelihood and welfare cannot be neglected. The role of the rainforest biodiversity in agriculture - the backbone of rural life in Tanzania - also seems high.

However, despite the likely many benefits from the rainforest and its biodiversity, conservation efforts by forest authorities are in conflict with the present practices of forest product exploitation. Increased rate of collection from the forest due to population growth, coupled with increased demand for other resources such as land for cultivation, has led to relentless gross violation of forest rules particularly when it comes to fulfillment of local people's basic needs. Violation of the Forest Reserve boundary, indiscriminate cutting of trees for timber and poles, construction of dwelling huts, setting fires and encroachment for cultivation are among the activities which threaten the rainforest. Many of these activities were initially limited to unreserved forests outside the Forest Reserve boundaries and the buffer zones. The study has shown that most of the activities are now carried out just on the rainforest periphery and sometimes inside the Forest Reserve itself. In fact the intensive use of land in the buffer zone, using unsustainable farming practices such as cultivation on river/stream banks and steep slopes, without soil conservation measures, is spilling over into the Forest Reserve such that the buffer zone between the village and the Forest Reserve boundary no longer serves its purpose as it has virtually disappeared.

Gaps in the Forest Reserve and the clear distinction between the Forest Reserve boundary and adjacent farmland, is an indication of the extent of damage in the initially forested buffer zone. The gaps in the Forest Reserve need to be filled by gap filling or enrichment planting to enhance biodiversity. One main reason for the degraded forest situation is failure by the forest authorities to enforce property rights regimes and forest laws due to lack of human and financial resources and lack of control in the use of land in the buffer zone. Due to lack of resources, a Forester now controls a large area of about 14216 ha of forest situated up to about 20 km from his residence with about 42 km of forest boundary to patrol. Effective control of such an area is questionable under the existing transport facilities and inaccessibility of some area on the mountain slopes.

Patrolling by guards and the imposition of penalties to discourage encroachment and illegal activities have been historically practiced using the "on and off" basis, as major legislative

means to protect the Forest Reserve in the Nguru mountains. Due to its intermittent nature, it has proved not to be effective. When performed at increased pace, it has created disharmony with local communities leading to local people's negative attitude toward the protected forest, and in consequence enhancing the view of a Forester as a "policeman" enforcing government-imposed restriction on what people perceive to be their legitimate right to use the protected forest in their vicinity to earn a living. Under the pressure of the growing population and unsustainable landuse practices, this "policing" has fanned illegal activities and destructive encroachment. Forest law enforcement as the major means to protect the Forest Reserve has had discouraging results also due to villager's ambivalence behaviour toward the forests. Ambiguous Forest Reserve borders, neglected role of the buffer zones by forest authorities, lack of forest education on the local populace, high demand for forest products due to growing population in an environment of poverty are other factors enhancing forest law violation. There is urgent need to review forest protection practices and methods to devise a better approach.

Since most of these problems originate from the local communities, one of the clearest lessons is that conserving biodiversity in the protected forest cannot be achieved without involvement of the people in forest management and providing them with a good share of benefits from the protected forest. Excluding these poor people, who are endowed with limited resources, from access to the protected forest without providing them with alternative means of livelihood cannot achieve the objectives of biodiversity and forest conservation. Also community involvement in management and protection of the forests (participatory forest management) seem to be more feasible in the Nguru mountains because it creates harmonious relationships between the forest and the local communities. Thus the study enhances the recognition that, successful management and protection of the Forest Reserve, ultimately depends on the cooperation and support of the local people whose economic activities must be linked with protected forest management. There should also be improvement in enforcing property rights regimes. This can be achieved by strengthening the weak points in the property rights regime through clear specification of rights for various interest groups, updating existing laws, integrating forest use in other landuses and to clear uncertainties in property ownership. Furthermore, to protect forests in public lands, the forest laws must be made applicable to such lands. Local community rights must be integrated into such legislation to give them a share of benefits. Establishment of effective buffer zones around the protected forest must augment such effort.

Despite the operationalizing constraints to peoples participation and effective buffer zone management, successful biodiversity conservation and forest protection still need to be community-based conservation. Recognizing and institutionalizing peoples rights to benefit from a protected forest lies at the heart of the success. However, such rights should only empower people in aspects of development that do not lead to overexploitation or degradation of the protected forest. Caution is needed when providing these rights since a conflict of interest between rural people's ability to earn a living and forest protection objectives is always likely. Besides community participation and buffer zone establishment in biodiversity conservation, this study also enhances the realization that conserving biodiversity cannot be regarded solely as an issue of local landuse practices because threats to the Forest Reserve are a consequence of much broader issues than local land management alone. Thus, although the study points at the local

people as the most visible agents of forest degradation, their actions are also attributable to laws, policies, patterns of resource access, social changes and economic forces all of which originate far from, and beyond the reach of local communities. In this case therefore, the Government must augment local biodiversity conservation efforts by a political commitment to change the situation through various policy measures such as giving priority to clarifying and establishing secure land tenure rights, resource access for individuals and communities adjacent to the Forest Reserves and persuading farmers to adopt and practice long-term perspective toward landuse including more intensive cultivation outside the Forest Reserve.

Thus, the following is an outline of some important steps to be taken to improve the role of buffer zones and other control mechanisms in protecting the rainforest and its biodiversity in the Nguru mountains:

- (i) Revise forest laws to reflect community participation in forest management coupled with an education campaign to educate the local population on benefits of protecting the rainforest and educating forest guards to behave responsibly while on and away from duty for the sake of good public relations.
- (ii) Regulate the number of licenses issued for forest harvesting and increase control on conditions of license to ensure sustainable practices in the forest.
- (iii) Provide villagers with right to protected forest resource use so that by reaping direct benefits they can build interest to protect the forest. Transparent contractual arrangements can help. Also legal rights of nontimber forest product collectors and local forest communities need to be clearly understood by all parties.
- (iv) Involve local people in protected forest management through dialogue and persuasion to elicit their participation in formulating and implementing solutions to forest related problems.
- (v) Review property rights regimes to clearly redemarcate the buffer zone area in relation to forest reserve and public unreserved land. This must be augmented with more control of the activities in the buffer zone and education on its role.
- (iv) Regulate activities in the buffer zone to check spilling of these activities into the protected forest.
- (v) Encourage villagers to use bricks as construction material instead of poles, and energy efficient systems for wood fuel to reduce heavy dependency on the rain forest. Government or Non-government financial support through providing soft loans such as for brick housing, energy-saving stoves or improving farming could help.
- (vi) Initiate and encourage crop-tree farming through fuel woodlots, fuelwood plantations or agroforestry practices with emphasis on perennial crops for soil conservation
- (vii) Extend family planning services to control population growth which is a driving force to environmental degradation.
- (viii) Increase control of cultivation on stream/river banks and very steep areas.
- (ix) Improve agricultural support by better prices and credit facilities to raise productivity.
- (x) Look into possibilities of renting out small rainforest patches of high economic value to willing private companies.
- (xi) Determine quantitatively the economic value of nontimber forest products and use this to strike a balance between economic value and ecological benefits and services of nontimber

forest products.

- (xii) Set up village level improved forest-based processing enterprises so that benefits of nontimber forest products as well as value added stay with the people around the rainforest. These enterprises must maintain the traditional characteristics of nontimber forest product activities by keeping them small and household or community-based and giving women first priority. Government should serve as a facilitator through provision of easy access to financial credit, management and price support, infrastructure, appropriate technology and skills, law and order services while freedom of economic decision making is left to the people.
- (xiii) Encourage policies which take into account socio-cultural issues such as traditional knowledge, ethnicity and social morals since these may be crucial in determining the success of forest protection. These policies should also integrate nontimber forest products into mainstream economic activities.

Some of these recommendations may be easier to implement than others, but time is running out and forest resources are under increasing pressure. Integrating nontimber forest products into timber management seems plausible than the current timber-dominated management in order to improve rainforest protection. This is so because nontimber forest products are most successfully linked to participatory forms of forest management when clear access and tenure are provided. Nonetheless, these recommendations are not a panacea and several issues still need to be researched on. Several aspects related to the tropical rainforest are pertinent further research issues. Based on the experience from the present study, the following are possible topics for further research:

- Valuing the rainforest to assess the economic value of nontimber forest products on individual tree or per hectare basis rather than on per species level.
- Assessment of harvesting costs and income from tropical rainforest nontimber forest products
- Comparative analysis of timber benefits versus nontimber benefits from the tropical rainforest
- Quantifying the impact of forest sector policies on tropical rainforest protection
- Evaluation of the role of community participation programmes in sustainable forest management: A Case of pilot projects in the Nguru mountains or conserving forests as if people matter.
- Biodiversity responses to selective harvesting through pitsawing
- Role of existing property rights on tropical rainforest protection
- Uncertainties in methods of assessing the economic value of nontimber forest products from the tropical rainforest
- Long-term ecological studies to verify the results of ethnobotanical studies in valuing the tropical rainforest
- Assessment of yield, cost and value of tropical rainforest nontimber forest products
- Comparative study of timber value versus nontimber value of the tropical rainforest
- Labour and time investment costs in collecting nontimber forest products from the tropical rainforest
- Studies on reasons for public policy failure to promote marketing, processing and development of nontimber forest products
- Comparative economics study for justifying the preservation of the tropical rainforest

- Monitoring and accounting for variation in production levels and harvesting costs of nontimber forest products of the same species in the rainforest.
- A study of the behaviour of illegal pitsawyers
- A study of the relationship between timber inventory, rate of detection of illegal pitsawyers and varying number of forest guards
- Analysis of optimal harvest and patrolling policies
- Studies on regeneration rates, yield, extraction management, processing, storage and markets for nontimber forest products
- Assessment of impacts of product substitution and new markets for nontimber forest products
- Investigation on appropriate technologies for maximization of benefits to collectors and producers of nontimber forest products
- How to develop nontimber forest products: options available
- Viability of commercializing nontimber forest products as "eco-protection enterprises".
- Role of institutions in developing nontimber forest products and their markets
- Problems of value addition and organizational management of nontimber forest products
- Valuation of nontimber forest products: methodologies for quantification and valuation
- Role of collection agents, contractors, middlemen, transporters, wholesalers and retailers for various nontimber forest products from the rainforest.

REFERENCES

- Adger, W.N. and K. Brown 1994. Land use and the causes of global warming. Centre for Social and Economic Research on the Global Environment, University of East Anglia and University College London, UK. John Wiley & Sons, 271 pp.
- Ahlback A.J. 1992. Why and How to mobilize all rural people of Tanzania to tree planting. A Ph.D. Thesis submitted to the Faculty of the Graduate School of the University of Minnesota. 408 pp.
- Axelrod, D.L. & P.H. Raven 1978. Late Cretaceous and Tertiary vegetation history of Africa. In M.L.A. Werger (ed.): *Biogeography and Ecology of Southern Africa*. Junk, The Hague (den Haag).
- Bishop, R.C. 1978. Economics of endangered species. *American Journal of Agricultural Economics* 60:10-18.
- Bjørndalen, J.E. 1992. Tanzania's vanishing rain forests-assessment of nature conservation values, biodiversity and importance for water catchment. *Journal of Agriculture, Ecosystems and Environment*, 40:313-334.
- Bojö, J. 1991. Economic analysis of environmental impacts. In: Folke, C. & T. Kåberger (eds.), *Linking the natural environment and the economy: Essays from the Eco-Eco Group*. Kluwer Academic Publishers, Dordrecht, The Netherlands, p. 43-59.
- Brandon, K. and M. Wells 1992. Planning for people and parks: design dilemmas. *World Development* 20, 557-570.
- Brenam, J.P.M. 1978. Some aspects of the phytogeography of Tropical Africa. *Annals of Missouri Botanical Garden*, 65:437-478.
- Butera, J. & G.S. Klem 1983. Pitsawing and small scale sawmilling in Rwanda. University of Dar es salaam, Division of Forestry Record No. 27, Morogoro.
- CFP, 1991. Managing the catchment forest reserves: Who is to be involved? A socio-economic study prepared for the Catchment Forest Project, Forestry and Beekeeping Division, Dar es Salaam, Tanzania. 35 pp+ appendices.
- CFP, 1992. Morogoro Region Catchment Forestry Project, Morogoro.
- CFP, 1993. Morogoro Region Catchment Forestry Project, Morogoro.
- CFP, 1994. Morogoro Region Catchment Forestry Project, Morogoro.
- Chamshama, S.A.O.; V.R. Nsolomo & A. Persson, 1990. Human impacts on the forest vegetation of the Nguru mountains, Tanzania. In: I. Hedberg & E. Persson (eds.), *Research for conservation of the Tanzania catchment forests. Proceedings from a workshop/seminar held in Morogoro, Tanzania, 13-17 March, 1989*, Uppsala, pp. 150-154.
- Ehrenfeld, D. 1988. Why put a value on biodiversity? In *Biodiversity: Wilson, E.O. (ed.)*. National Academy Press, Washington, p. 212-216.
- FAO, 1988. An Interim report on the state of forest resources in the developing countries. FAO Forest Resources Division, Forest Department. FO:MISC/88/7. FAO, Rome.
- Fergus, M., G. Kitambi, A. Seim, R. Skaar & B. Solberg 1977. Report on an evaluation of the Sao Hill Sawmill Project, Tanzania. NORAD, Ministry of Finance and Planning, Oslo. 180 pp.+ app.
- Folke, C., K.-G. Mäler & C. Perrings 1992. Biodiversity Loss: an introduction. *AMBIO XXI(3):200*.

- Fottland, H. 1993. Maintenance and management of natural forests in Tanzania. Contribution at Seminar for Norwegian Volunteers and Counterparts working in the Agricultural and Environmental Sector in Tanzania, Morogoro 15 - 16 October 1993. The Catchment Forestry Project, Forestry and Beekeeping Division, Ministry of Tourism, Natural Resources and Environment, Dar es Salaam.
- Furtado, J.I., W.B. Morgan, J.R. Pfafflin & K. Ruddle 1990 (eds.). Tropical resources ecology and development. Harwood Academic Publishers. p. 69.
- Hamilton, A.C. & R. Bensted-Smith 1989. Forest conservation in East Usambara mountains. IUCN, Gland. 392 pp.
- Hamilton, A.C. & I.V. Mwashia, 1989. History of resource utilization and management under German Rule. In: Hamilton A.C. & R. Bensted-Smith (eds.) Forest conservation in the Usambara mountains. IUCN, Gland. pp. 39-40.
- Hågvar, S. 1994. Preserving the natural heritage: The process of developing attitudes. *AMBIO* XXIII(8):515-518.
- Hermansen, J.E.; Benedict F.; Corneliussen T; Hofsten J.; and Venvik H. 1985. Catchment forestry in Tanzania, status and management. NORAD Consultancy Report 17-18. Institute of Environmental Analysis and FORINDECO, Norway.
- Hilliard, O.M. & B.L. Burt. 1971. *Streptocarpus*, an African plant study. Pietermaritzburg, University of Natal Press.
- Hofstad, O. 1992. Management of public forests in the presence of illegal felling. *Scandinavian Forest Economics*, 33:548-557.
- IDA, 1992. The Environment. In: IDA operations. International Development Association (IDA), IDA 10 Technical Note 4: April, 9 pp.
- ITTO, 1990. ITTO guidelines for the sustainable management of natural tropical forests. ITTO Technical Series 5, Yokohama: International Tropical Timber Organization (ITTO), 18 pp.
- Iversen, S.T. 1989. Conservation of the Usambara mountains: Botanical values at the species and phytogeographical level. *Acta Universitatis Upsaliensis Symbolae Botanicae Upsalienses*, Uppsala, 28(3):218-243.
- Iversen, S.T. 1991. The Usambara mountains, NE Tanzania: Phytogeography of the vascular plant flora. *Acta Universitatis Upsaliensis Symbolae Botanicae Upsalienses*, Uppsala, 19(3):1-234.
- Jaako Pöyry, 1992. Industrial restructuring study on wood and paper industry - Tanzania. Fact Book. The Swedish International Development Authority (SIDA). Summary, 8 pp.
- Kalaghe, A. G.; T. H. Msangi & L. Johansson, 1988. Conservation of catchment forests in the Usambara mountains. *Tanzania Association of Foresters Journal* No. 6:37-47.
- Kaoneka, A.R.S. 1990. Measures to contain the problem of encroachment in natural forests. Sokoine University of Agriculture, Faculty of Forestry Record No. 43:126-130.
- Kaoneka, A.R.S. 1993. Land use in the West Usambara mountains: Analysis of ecological and socio-economic aspects with special reference to forestry. Dr. Scient. Thesis, Department of Forestry, Agricultural University of Norway. Report No. 2, 78 pp.
- Kijoti, W.E. & M.G. White 1981. Pitsawing in the Pare mountains of Tanzania. Division of Forestry, University of Dar es Salaam, Morogoro. Record No. 21, 11 pp.
- Klem, G.S. 1978. Planning of sawmilling industry in Africa: possible sources of energy.

- University of Dar es Salaam, Division of Forestry Record No. 1, Morogoro. 17 pp.
- Kowero, G.S. 1990. Management and utilization of forest estates in Tanzania: Some policy issues. *Journal of World Forest Resource Management* 8(1):15-27.
- Kowero, G.S. and O. Hofstad 1989. Economic aspects of Tanzanian Forestry. Tanzania Forestry Action Plan (TFAP), Sector Review Mission, Report No.7. Forestry and Beekeeping Division, Ministry of lands, Natural Resources and Tourism, Dar es Salaam. 25 pp.
- Lovett, J.C. 1988. Endemism and affinities of the Tanzanian montane forest flora. *Monographs in Systematic Botany*. Missouri Botanical Garden, 25:591-598.
- Lovett, J.C. 1989. The botanical importance of the East Usambara forests in relation to other forests in Tanzania. In: A.C. Hamilton and R. Bensted-Smith (eds.), *Forest conservation in the East Usambara mountains, Tanzania*, IUCN, Gland, Switzerland and Cambridge, U.K. pp. 207-212.
- Lovett, J.C. & Thomas D.W. 1988. Report on a visit to Kanga mountains, Tanzania. *Eastern African Natural History Society Bulletin*, 18(2):19-22.
- Lovett, J.C. & T. Pócs 1993. Assessment of the condition of Catchment Forest Reserves: A botanical appraisal. *Catchment Forestry Report* 93.3. The Catchment Forestry Project, Forestry and Beekeeping Division, Ministry of Tourism, Natural Resources and Environment, Dar es Salaam. 271 pp.
- Lundgrén, B. 1985. Catchment forestry in Tanzania. A revised report for the joint Tanzania/Nordic Forestry Sector Review 1985. Regional soil conservation Unit/SIDA, Nairobi.
- Mackinnon, J., K. Mackinnon, G. Child, and J. Thorsell 1986. Managing protected areas in the tropics. IUCN, Gland, Switzerland.
- Mäther, S. 1989. Saintpaulia. In: A.C. Hamilton & R. Bensted-Smith (eds.), *Forest conservation in the East Usambara mountains, Tanzania*, IUCN, Gland, Switzerland, and Cambridge, U.K. pp. 181-183.
- McNeely, J.A. 1993. Economic incentives for conserving biodiversity: Lessons for Africa. *AMBIO* XXII(2-3):144-150.
- Milner-Gulland, E.J. and N. Leader-Williams 1992. A model of incentives for illegal exploitation of rhinos and elephants: Poaching pays in Luangwa Valley, Zambia. *Journal of Applied Ecology*, 29.
- Mitzlaff, U.V. 1991. Managing the catchment forest reserves: Who is to be involved? A socio-economic study prepared for the Catchment Forest Project, Forest and Beekeeping Division, Dar es Salaam, Tanzania. 35 pp.+ appendices
- Monela, G.C. 1995a. Rainforest degradation and landuse in the Nguru mountains, Tanzania: Analysis of socio-economic and ecological aspects. Dr. Scient. Thesis submitted to the Department of Forest Sciences, Agricultural University of Norway, Aas. Report No. 1.
- Monela, G.C. 1995b. Analysis of the use of tropical rainforest species and evaluation of buffer zones and other control mechanisms in preserving the tropical rainforest adjacent to Mhonda village in the Nguru mountains, Tanzania. Dr. Scient. Thesis submitted to the Department of Forest Sciences, Agricultural University of Norway, Aas. Report No. 2.
- Monela, G.C. 1995c. Socio-economic analysis of deforestation of tropical rainforests as a consequence of agriculture productivity, risks and population growth: a case study of

- Mhonda village in the Nguru mountains, Tanzania. Dr. Scient. Thesis submitted to the Department of Forest Sciences, Agricultural University of Norway, Aas. Report No. 3.
- Mnzava, E.M. 1980. Fuelwood and charcoal in Africa. Conference proceedings from energy from biomass, Brighton U.K. November, 1980. Applied Science Publishers, London.
- Mnzava, E.M. & P. Riihinen 1989. Forestry and landuse policy and administration. Tanzania Forestry Action Plan (TFAP) Sector Review Mission Report No. 9. Forestry and Beekeeping Division, Ministry of Lands, Natural Resources and Tourism. 36 pp.
- MTNRE, 1992. The Forest (Amendment) Rules, 1992. The Forest Ordinance CAP 389. Government Notice No. 251. Ministry of Tourism, Natural Resources and Environment, Dar es Salaam. p. 498-504.
- MTNRE, 1993. The Forest (Amendment) Rules, 1993. The Forest Ordinance CAP 389. Government Notice No. 265. Ministry of Tourism, Natural Resources and Environment, Dar es Salaam. p. 1-28.
- Munasinghe, M. 1992. Environmental economics and sustainable development. World Bank Environment Paper No. 3. The World Bank, Washington D.C., p. 1-39.
- Mwalyosi, R.B.B. 1990. Resource management in semi-arid areas. The case of Maasai Steppe of northern Tanzania. Dr. Scient. Thesis. Department of Biology and Nature Conservation. Agricultural University of Norway. 103 pp. + app.
- Navrud, S. 1993. Economic value of biological diversity in Norway. In: Linddal M. & Naskali A. (eds.). Proceedings of the Workshop, Valuing Biodiversity on the social costs of and benefits from preserving endangered species and biodiversity of the Boreal forests Espoo, Finland, October 1992. Scandinavian Forest Economics No. 34, 1993, p. 4-17.
- Næss, A. 1986. Intrinsic value. Will the defenders of nature please rise?. In Conservation Biology. Sólule M.E. (ed.). Sinauer Associates, Sunderland, Massachusetts, p. 504-515.
- NCSSD, 1994. National Conservation Strategy for Sustainable Development. Tanzania National Environmental Management Council, Proposal. January 1994. 58 pp.
- NEAP, 1994. National Environmental Action Plan: A first Step, Tanzania. The National Environmental Policy, Division of Environment, Ministry of Tourism, Natural Resources and Environment, United Republic Of Tanzania. 43 pp.
- Norris, S.R.V. 1990. Using aerial photographs and GIS in quantifying deforestation of tropical rainforest: A case study from the Nguru mountains, Tanzania. Unpublished M.Sc. Dissertation in Management of Natural Resources and Sustainable Agriculture (MNRSA), NORAGRIC, Agricultural University of Norway, Ås, 120 pp.
- Nsolomo, V.R. & S.A.O. Chamshama, 1990. Human impacts on some catchment forest reserves in Morogoro region. Sokoine University of Agriculture, Faculty of Forestry record No. 43:39-45.
- Panayotou, T. & P.S. Ashton 1992. Not by timber alone: Economics and ecology for sustaining tropical forests. Island Press, Washington D.C. 282 pp.
- Pearce, D. 1993. Economic values and the natural world. Earthscan Publications Ltd, London. 129 pp.
- Pearce, D., A. Markandya and E.B. Barbier 1992. Blueprint for a Green economy. Earthscan Publications Ltd, London. p. 51-92.
- Pearce, D. and D. Moran 1994. The economic value of biodiversity. IUCN, The World Conservation Union. Earthscan Publications Ltd., London, 172 pp.

- Pócs, T. 1974. Bioclimatic studies in the Uluguru mountains (Tanzania, East Africa). I. Acta Botanicae Academiae Scientiarum Hungaricae, 20:115-135.
- Pócs, T. 1975. Affinities between the bryoflora of East Africa and Madagascar. Boissiera, 24:125-128.
- Pócs, T. 1982. The forest flora and vegetation of the old crystalline mountains of Tanzania and their importance for soil and water conservation. In: Seminar/workshop on forest conservation in Tanzania, Tanga 16-18 February, 1982, 5 pp.
- Pócs, T. 1988. The importance of catchment forests to Tanzania. Professorial Inaugural Lecture, Sokoine University of Agriculture, Morogoro, Tanzania. 11 pp.
- Pócs, T. 1990. The gene pool values and their conservation in the natural forests. Sokoine University of Agriculture, Faculty of Forestry Record No. 43 pp. 16-32.
- Pócs, T., R.P.C. Temu, & T.R.A. Minja, 1990. Survey of the natural vegetation and flora of the Nguru mountains. In: I. Hedberg and E. Persson (Editors). Research for conservation of Tanzanian catchment forests. Proceedings from a workshop held in Morogoro, Tanzania, Tanzania, 13-17 March, 1989, Uppsala, pp. 135-149.
- Polhill, R.M. 1968. Tanzania. In: conservation of vegetation in Africa south of the Sahara. Uppsala, Sweden, Acta phytogeography Suecica, 54: 166-178.
- Randall, A. 1987. Resource economics: An economic approach to natural resource and environmental policy. Wiley, New York. 434 pp.
- Randall, A. 1991. The value of biodiversity. AMBIO 20, 64-68.
- Randall, A. 1993. Thinking about the value of biodiversity. In: Linddal M. & Naskali A. (eds.). Proceedings of the Workshop, Valuing Biodiversity on the social costs of and benefits from preserving endangered species and biodiversity of the Boreal forests Espoo, Finland, October 1992. Scandinavian Forest Economics No. 34, 1993, p. 4-17.
- Repetto R. & M. Gillis (eds.) 1988. Public policies and the misuse of forest resources. Cambridge, Eng.: Cambridge University Press. 432 pp.
- Rodgers, W.A. & K.M. Homewood, 1982. Species richness and endemism in the Usambara mountain forests, Tanzania. Biol. J. Linn. Soc. 18:197-242.
- Rodgers, W.A. and J.B. Hall 1986. Pole cutting pressure in Tanzanian forests. Forest Ecology and management, 14:133-140.
- Ruffo, C.K., C. Mmari, S.P. Kibuwa, J. Lovett, S. Iversen & A.C. Hamilton, 1989. A preliminary list of plant species recorded from the East Usambara forests. In: A.C. Hamilton and R. Bensted-Smith (eds.), Forest conservation in the East Usambara mountains, Tanzania. IUCN, Gland, Switzerland and Cambridge, U.K., pp. 157-179.
- Ryan, J.C. 1992. Conserving biological diversity. In: L. Brown *et al.*, State of the World. W.W. Norton & Company, N.Y. USA. p. 10-14
- Sayer, J. 1991. Rainforest buffer zones: Guidelines for protected area managers. IUCN, Gland. 94 pp.
- Sharma, N.P. (ed.) 1992. Managing the World's Forests: Looking for balance between conservation and development. The World Bank. Kendall/Hunt Publishing Company, Iowa, 605 pp.
- Skage, T. & L.O. Næss 1994. Pitsawing and sustainable forest management. A case study of ecological and social considerations from Morogoro District, Tanzania. M.Sc. Forestry Thesis, Department of Forestry, AUN. 147 pp.

- Solberg, B. 1988. Choice of technology in less industrialized countries with particular reference to forestry and sawmilling. Agricultural University of Norway, Department of Forest Economics, Report No. 3/1988, p. 41-43.
- √Solberg, B., H.F. Hoen, A.R.S. Kaoneka, G.C. Monela & J. Valen 1994. Forest resources and structural adjustment - A review of studies and literature on Tanzania and suggestions for future research priorities. Ecology and Development Paper. Published by the Ecology and Development Programme, The Agricultural University of Norway, Ås, 50 pp.
- Taylor, P.W. 1986. *Respect for Nature*. Princeton University Press, New Jersey, 329 pp.
- Tewari, D.D. 1994. Developing and sustaining nontimber forest products: Policy issues and concerns with special reference to India. *Journal of World Forest Resource Management*, Vol. 7, pp.151-178.
- √TFAP, 1989. Tanzania Forestry Action Plan 1990/91-2007/08 and Technical Annexes, Vol. I, II, VIII & IX. Ministry of Lands, Natural Resources and Tourism, Dar es Salaam, Tanzania.
- Thomas, R. & G.B. Straley 1993. Biodiversity in the British Columbia. Research Branch, British Columbia, Ministry of Forest. p. 1-4.
- Tilling, A.J. 1994. Realizing the potential of non-timber forest products: The predicament of West coast indigenous forest-based users in the South island, New Zealand. *Journal of World Forest Resource Management*, Vol. 7, pp. 129-150.
- Veisten, K., H.F. Hoen, S. Navrud and J. Strand 1993. Valuing biodiversity in Norwegian forests: A contingent valuation study with multiple bias testing. Research programme on Socio-economic consequences of multiple-use forestry at the Department of Forestry, Agricultural University of Norway, Aas. p. 1-17.
- WCED, 1987. *Our Common Future*. The World Commission on Environment and Development. Oxford University Press. Oxford, New York. 400 pp.
- Wells, M.P., K.E. Brandon & L. Hannah 1992. People and Parks: Linking protected area management with local communities. World Bank, Washington, D.C.
- Wells, M.P. & K.E. Brandon 1993. The principles and practice of buffer zones and local participation in biodiversity conservation. *AMBIO XXII(2-3):157-162*.
- Westoby, J.C. 1975. Making trees serve people. *Commonwealth Forestry Review*. 54(3/4):206-215.
- White, F. 1978. the Afromontane region, in Werger, M.J.A.(ed.) *Biogeography and Ecology of Southern Africa*: 463-512. Junk, The Hague.
- White, F. 1983. *The vegetation of Africa*. UNESCO; Paris, 356 pp.
- Wilson, E.O. (ed.) 1988. *Biodiversity*. National Academy Press, Washington, 521 pp.
- WRI, IUCN & UNEP 1992. *Global biodiversity strategy: Guidelines for action to save, study, and use Earth's biotic wealth sustainably and equitably*. World Resources Institute (WRI), The World Conservation Union (IUCN), and United Nations Environment Programme (UNEP) in consultation with Food and Agriculture Organization (FAO), and United Nations Education, Scientific and Cultural Organization (UNESCO), 244 pp.

Personal Communications

- Kalebi, A.K. 1994. District Catchment Forest Officer, Morogoro.

- Kalebi, A.K., R. Njana & T. Torstad 1994. Catchment Forest Project, Morogoro
- Njana, R. 1994. Regional Catchment Forest Officer Morogoro.
- Torstad, T. 1994. Norwegian Volunteer, Advisor, Catchment Forest Project, Morogoro.

APPENDIX 1. SAMPLE QUESTIONNAIRE FOR HOUSEHOLD DATA

1. Village name.....
2. Age of respondent.....
3. Level of education.....
4. Marital status.....
5. Number of people in a household.....
 - (a) Adults.....
 - (b) Children.....
6. What forest-based sources of income or economic activities are you engaged.....
7. Where is your farm holding located relative to the rain forest boundary.....
8. How is additional land for farm expansion obtained.....
9. Extent of soil erosion in the farm holding
 - (a) High.....
 - (b) Moderate.....
 - (c) Low.....
10. Extent of soil fertility in your farm holding
 - (a) High.....
 - (b) Moderate.....
 - (c) Low.....
11. What tree products do you produce from your farm
12. What products are obtained from the tropical rain forest? Estimate the quantity and value.....
 - (a) Products for domestic use.....
 - (b) Products for local sale.....
 - (c) Products for sale outside the local community.....
 - (d) Products for other uses.....
13. What forest products are obtained from the zone adjacent to the rain forest.....
14. What forest products are collected by adult males.....
15. What forest products are collected by adult females.....
16. What forest products are collected by children.....
17. Fuelwood consumption
 - (a) Main source.....
 - (b) Travel distance to collect fuelwood.....
 - (c) Headloads per week.....
18. Are you permitted to collect forest products on the periphery of the rain forest
.....What about entering the rain forest.....
19. What institutional use rights do you have on the forest reserve.....
20. Have these rights influenced your decisions to grow trees on your farm.....
21. What soil erosion control measures do you use on your farm.....
22. Do you use fertilizer or manure to maintain soil fertility.....
23. What land tillage and planting technique is used.....
24. What changes in your village have you noted as a result of decreasing forest
cover?.....
25. What are the main reasons for forest cover decline?.....

- 26. Are there any plant species which have disappeared as a result of forest cover decline?.....
- 27. Name those species.....
- 28. What changes in vegetation cover have occurred in the zone adjacent to the rain forest.....
- 29. What forest products formerly collected in the buffer zone and now have to be collected inside the rain forest.....
- 30. What plant species are locally used for any of the following purposes?

Purpose	Species used	Source of plant	Section of plant used	Processing technique
Fuelwood Food Fruit Fodder Building poles Local medicine Shade Soil erosion control Green manure Honey Other uses				

- 31. Could benefits from the tropical rainforest be improved without destroying the forest?
 - (a) Yes.....
 - (b) No.....
- 32. If yes, in what ways?
 - (a) Demarcating part of the rain forest as "extractive forest reserves" for sustainable local uses while maintaining biodiversity.....
 - (b) Developing buffer zones to cater for local forest needs
.....
 - (c) Law enforcement should be reinforced with aggressive forest extension.....
 - (d) People's should be allowed to participate in forest decisions that affect them.....
 - (e) The village should be allowed to collect some taxes from the forest to raise cash for investing in forest matters
.....
 - (f) Pursuing laws which recognize the traditional rights of local people to harvest forest products in different categories of reserves.....
 - (g) Manage the forest for multiple use to accommodate competing interests
.....
 - (h) Environmental impact assessment to monitor changes in the resource stocks.....

- (i) Establish management agreement between the state and the local people.
33. What changes in species composition are discernible in pitsawn areas in the tropical rain forest?
- High reduction
 - moderate reduction
 - low reduction
 - No reduction
34. What tree species do you frequently encounter in your daily forest product uses.....Species in the buffer zone.....Species inside the rain forest.....
35. If your farm holding is located in the zone adjacent to the rain forest do you grow do you have trees (grown or retained) on your farm?
- Grown.....
 - Retained.....
36. If no, why?.....
If yes, What species and where in the farm?
- Along the farm border.....species.....
.....
 - In specific sites within the farm.....species.....
.....
 - Intercropping trees with crops.....species.....
.....
 - Natural trees left out in the farm.....species.....
37. For what purpose are the trees in the farm?
- Indigenous tree species.....
 - Exotic tree species.....
38. What property rights do you have on these trees?.....
39. How do you perceive the extent of forest product harvesting
- Normal.....
 - Moderate.....
 - Excessive.....
40. Do you sometimes buy forest products for household consumption?.....
If yes, what products and at what price.....
41. How do you rank the position of forest products supply?
- Good.....(ii) Bad.....(iii) Very bad.....
42. What is the perceived damage/degradation to the rain forest due to human activities
- low.....(b) moderate.....(c) high.....(d) Excessive.....(e) none.....
43. What are the perceived main causes of rain forest degradation.....
44. Why do you often violate rain forest protection laws/regulations.....
45. What incentives would attract you to participate in protect the forest reserve.....
- harvesting rights for local products.....
 - casual employment.....
 - land to cultivate.....
 - ecological stability.....
 - grazing rights.....

- (f)water needs.....
- (g)other.....
46. How best can the interests of the local community and those of the state be accommodated in preserving the tropical rain forest?
- (a)Involve the local people in decisions affecting their daily life.....
- (b)Provide alternatives before restricting people to use the forest.....
- (c)Educate the people that state aims for sustaining the rain forest.....
- (d)Forest personnel living in the local community should abide their work ethics.....
- (e)Establish buffer zone to meet local needs without intrusion into the forest reserve....
- (f)Provide means for local people to grow trees.....
47. Why do you cultivate in the buffer zone, hills and stream banks?.....
48. Why expansion of the farm is towards the forest reserve?.....
49. Why do you clear your land by starting fires on the borders of the forest reserve.....
50. How is tree cover in the buffer zones?.....
51. What specific products do you obtain exclusively from the buffer zones?.....
52. Are there any specified parts of the rain forest where you are allowed to harvest forest products.....
53. Are your traditional use rights to harvest local forest products in the natural forest respected?.....
54. What activities do you consider detrimental to the forest reserve.....
55. Why do you think those activities continue unabated.....
56. Do you think planting rows of exotic trees on the periphery of the rain forest an effective way to protect it.....
57. Suggest some ways which in your opinion would help to protect the rain forest.....
58. What traditional rights have been interfered by the forest reserve.....How has you reacted to preserve these rights.....
59. Do you know any traditional taboos aimed at protecting some trees.....
What trees are protected by such taboos.....
60. What time of the year is collection from the forest mainly done.....
61. Specify the products collected.....
62. Are plants producing such products easily found.....Specify the area.....
63. What methods are used to extract such products.....
64. Is pitsawing practiced.....By whom.....Name the species pitsawn.....
65. What changes in vegetation are caused in pitsawn areas.....
66. State the local effects of pitsawing.....
67. Are the pitsawyers local people or immigrants?.....Who employs them.....?
68. Where is the timber from pitsawing sold.....
69. What do you know about basic rules and regulations that govern the forest reserve.....
70. If your own a plot near a stream estimate the distance between your farm boundary

and the water course.....

- 71. What do you know of the buffer zone functions.....
- 72. Are you aware of villagers being arrested for violating forest rules.....
How many times.....Reason for arrest.....Number of people
arrested..... Action taken against them.....
- 73. How frequently do you meet forest guards when collecting forest products in the rain
forest.....
- 74. What is the major use of land between the village and the rain forest
boundary.....
- 75. Do you think growing trees on farm adjacent to the rain forest would help to reduce
pressure on the rain forest.....

APPENDIX 1.2 QUESTIONNAIRE FOR PITSAWING COSTS AND BENEFITS

1. Where do the pitsawyers come from.....
2. Who employs the pitsawyers.....
3. Which tree species are sawn.....
4. Which are the most preferred species.....
5. Where are these trees found.....
8. How is the availability of such trees.....
9. Explain the licensing procedure
10. What are the conditions of the license.....
11. Is licensing practice working well to control harvesting.....If not why?.....
12. Where is sawn wood used.....
13. How is sawn timber transport arranged.....
14. What is the impact of pitsawing on vegetation cover in pitsawn areas.....
15. What is the price of sawn timber at the roadside by size and per cubic meter.....
16. What is the salary of pitsawyers.....
17. What other fringe benefits do they get from their employer.....
18. How is illegal pitsawing arranged.....
19. What is its extent.....
20. In what ways can it be controlled.....
21. What problems are associated the licensing procedure.....
22. Cost of pitsawing equipment and life span.

Type of equipment	Buying price (T.Shs.)	Renting cost (T.Shs.)	Life span (years)
Saw for pitsawing			
Crosscut saw			
Axe			
Hoe			
Bushknife			
File			
Measuring tape			
Thread			

23. Labour costs for logging and sawing (wages for pitsawyers per species and unit of sawn timber).

Tree species (Trade name in parentheses)	Payment per sawn timber unit (T.Shs.)			
	1"12"12'	2"6"12'	2"8"12'	m ³
<i>Ocotea usambarensis</i> (Camphor)				
<i>Milicia excelsa</i> (Mvule)				
<i>Pterocarpus angolensis</i> (Muninga)				
<i>Khaya anthotheca</i> (Mkangazi)				
<i>Newtonia buchananii</i> (Mnyasa)				

24. Manual transport cost of sawn timber to the nearest roadside

Sawn timber unit	Payment (T.Shs.)
1"12"12'	
2"6"12'	
2"8"12'	
m ³	

25. What other costs are involved in pitsawing.....

APPENDIX 2. SPECIES COMPOSITION OF THE TROPICAL RAINFOREST AS
ENUMERATED IN THE BOTANICAL INVENTORY

Plant species in the rain forest	Family	Plant species in the rain forest	Family
<i>Dracaena deremensis</i>	Agavaceae	<i>Prunus africana</i>	Rosaceae
<i>Costus sarmentosus</i>	Zingiberaceae	<i>Balthasaria schliebenii</i>	Theaceae
<i>Allophylus abyssinica</i>	Sapindaceae	<i>Aningeria adolfi-friedericii</i>	Sapotaceae
<i>Allanblackia stuhlmanii</i>	Guttiferae	<i>Polyscias fulva</i>	Araliaceae
<i>Entandrophragma stolzii</i>	Meliaceae	<i>Ochna holstii</i>	Ochnaceae
<i>Hallea rubrostipulata</i>	Rubiaceae	<i>Ilex mitis</i>	Aquifoliaceae
<i>Diopsy species</i>	Ebenaceae	<i>Mammea africana</i>	Guttiferae
<i>Pterocarpus angolensis</i>	Papilionaceae	<i>Ekerbegia capensis</i>	Meliaceae
<i>Combretum species</i>	Combretaceae	<i>Dombeya leucoderma</i>	Sterculiaceae
<i>Milicia excelsa</i>	Moraceae	<i>Chrysophyllum albidum</i>	Sapotaceae
<i>Erythrophleum lasianthum</i>	Caesalpiniaceae	<i>Casearia battiscombei</i>	Flacourtiaceae
<i>Rapanea rhododendroides</i>	Myrsinaceae	<i>Cussonia spicata</i>	Araliaceae
<i>Pennisetum purpureum</i>	Panicaceae	<i>Afrocrania volkensii</i>	Cornaceae
<i>Rubus pennatus</i>	Rosaceae	<i>Aphloia theiformis</i>	Flacourtiaceae
<i>Manilkara sulcata</i>	Sapotaceae	<i>Urophyllum holstii</i>	Rubiaceae
<i>Acacia tanganyikensis</i>	Mimosaceae	<i>Tabernaemontana holstii</i>	Apocynaceae
<i>Diplorhynchus condylocarpon</i>	Apocynaceae	<i>Neoboutonia macrocalyx</i>	Oleaceae
<i>Tylosema fassoglensis</i>	-	<i>Myrica salicifolia</i>	Myricaceae
<i>Bridelia micrantha</i>	Euphorbiaceae	<i>Pauridantha holstii</i>	Rubiaceae
<i>Diospyros mespiliformis</i>	Ebenaceae	<i>Coffea canephora</i>	Rubiaceae
<i>Berchemia discolor</i>	Rhamnaceae	<i>Coffea eugeniodes</i>	Rubiaceae
<i>Sorindeia madagascariensis</i>	-	<i>Sclerocarya birrea</i>	Anacardiaceae
<i>Annona senegalensis</i>	Annonaceae	<i>Flueggea virosa</i>	-
<i>Ximenia caffra</i>	Oleaceae	<i>Lanea cornuta</i>	Mimosaceae
<i>Tetracarpidium conophorum</i>	-	<i>Gynandropsis gynandra</i>	-
<i>Azelia bella</i>	Caesalpiniaceae	<i>Bidens pilosa</i>	-
<i>Myrianthus arborea</i>	Moraceae	<i>Vigna unguiculata</i>	Papilionaceae
<i>Piper guineense</i>	-	<i>Ancylobothrys petersiana</i>	-
<i>Vitex payos</i>	Verbenaceae	<i>Talinum portulacastrum</i>	-
<i>Uapaca kirkiana</i>	Euphorbiaceae	<i>Amaranthus species</i>	-
<i>Protea chionantha var. divaricate</i>	Proteaceae	<i>Commelina species</i>	-
<i>Dionychastrum schliebenii</i>	Melastomataceae	<i>Piliostigma thonningii</i>	Caesalpiniaceae
<i>Chlamydostachya spectabilis</i>	Acanthaceae	<i>Ricinus communis</i>	Euphorbiaceae
<i>Lobelia morogoroensis</i>	Lobeliaceae	<i>Grewia flavescens</i>	Tiliaceae
<i>Lobelia lukwangulensis</i>	Lobeliaceae	<i>Hyptis spiliigera</i>	Labiatae
<i>Lobelia sancta</i>	Lobeliaceae	<i>Sterculia africana</i>	Sterculiaceae
<i>Saintpaulia pusilla</i>	Gesneriaceae	<i>Strychnos cocculoides</i>	Loganiaceae
<i>Amorphophallus stuhlmanii</i>	Araceae	<i>Azanza garckeana</i>	Malvaceae
<i>Isobertinia scheffleri</i>	Caesalpiniaceae	<i>Cyperus longi involucreatus</i>	Cyperaceae
<i>Afromomum usambarense</i>	Zingiberaceae	<i>Ixora tanzaniensis</i>	Rubiaceae
<i>Danais xanthorrhoea</i>	Rubiaceae	<i>Polyceratocarpus scheffleri</i>	Anonaceae
<i>Alligera madagascariensis</i>	Hernandiaceae	<i>Lagynias pallidiflora</i>	Rubiaceae
<i>Cussonia lukwangulensis</i>	Araliaceae	<i>Anisophyllea obtusifolia</i>	Rhizophoraceae
<i>Aloe schliebenii</i>	Liliaceae	<i>Urogentias uluguriga</i>	Gentianaceae
<i>Allanblackia uluguruensis</i>	Guttiferae		

Source: Own field data

APPENDIX 2 (continued). SPECIES COMPOSITION OF THE RAIN FOREST AS
ENUMERATED IN THE BOTANICAL INVENTORY

Plant species in the rain forest	Family	Plant species in the rain forest	Family
<i>Harungana madagascariensis</i>	Hypericaceae	<i>Trichocladus ellipticus</i>	Hamamelidaceae
<i>Hagenia africana</i>	Rosaceae	<i>Craibia brownii</i>	Papilionaceae
<i>Parkia filicoidea</i>	Araliaceae	<i>Clausena anisata</i>	Rutaceae
<i>Ocotea usambarensis</i>	Lauraceae	<i>Teclea nobilis</i>	Rutaceae
<i>Albizia species</i>	Mimosaceae	<i>Xymalos monospora</i>	Monimiacae
<i>Ceiba pentandra</i>	Bombacaceae	<i>Psychotria riparia</i>	Rubiaceae
<i>Khaya anthotheca</i>	Meliaceae	<i>Piper capense</i>	Piperaceae
<i>Trema orientalis</i>	Ulmaceae	<i>Pavetta hymenophylla</i>	Rubiaceae
<i>Newtonia buchananii</i>	Mimosaceae	<i>Pittosporum lanatum</i>	Pittosporaceae
<i>Begonia species</i>	-	<i>Lasianthus kilimandcharicus</i>	Rubiaceae
<i>Cyathea deckenii</i>	Cyatheaceae	<i>Memecylon cogniauxii</i>	Melastomataceae
<i>Catha edulis</i>	Celastraceae	<i>Myrsine africana</i>	Myrsinaceae
<i>Strombosia scheffleri</i>	Olacaceae	<i>Ensete ventricosum</i>	Musaceae
<i>Trichilia emetica</i>	Meliaceae	<i>Dodonea viscosa</i>	Sapindaceae
<i>Podocarpus milanjianus</i>	Podocarpaceae	<i>Pilotrichella cuspidata</i>	Euphorbiaceae
<i>Arundinaria alpina</i>	Gramineae	<i>Dasyplepis leptophylla</i>	Myricaceae
<i>Filicahoa laurifolia</i>	Theaceae	<i>Olea hochsteteri</i>	Oleaceae
<i>Milletia stuhlmanii</i>	Papilionaceae	<i>Gnidia glauca</i>	Thymeliaceae
<i>Parinari curatellifolia</i>	Chrysobalanaceae	<i>Randia taylorii</i>	-
<i>Sterculia appendiculata</i>	Sterculiaceae	<i>Vernonia holstii</i>	Compositae
<i>Syzygium guineense</i>	Myrtaceae	<i>Macaranga capensis</i>	Euphorbiaceae
<i>Vitex doniana</i>	Verbenaceae	<i>Raphia australis</i>	Palmae
<i>Faurea speciosa</i>	Proteaceae	<i>Phoenix reclinata</i>	Palmae
<i>Flacourtia indica</i>	Flacourtiaceae	<i>Celtis kraussiana</i>	Ulmaceae
<i>Beilschmedia kweo</i>	Lauraceae	<i>Erica caffra</i>	Ericaceae
<i>Terminalia sericea</i>	Combretaceae	<i>Philippia simii</i>	Ericaceae
<i>Ficus capensis</i>	Moraceae	<i>Vangueria cyanescens</i>	Rubiaceae
<i>Hyptis suaveolens</i>	Labiatae	<i>Lobelia gibberoa</i>	Campanulaceae
<i>Maerua triphylla</i>	Capparaceae	<i>Carapa grandiflora</i>	Meliaceae
<i>Gardenia jovis-tonantis</i>	Rubiaceae	<i>Clausena anisata</i>	Rutaceae
<i>Tamarindus indica</i>	Caesalpiniaceae	<i>Rhus vulgaris</i>	Anacardiaceae
<i>Dialium guineense</i>	Caesalpiniaceae	<i>Asparagus pauli-guilelmi</i>	Liliaceae
<i>Blighia sapida</i>	Sapindaceae	<i>Multidentia crassa</i>	-
<i>Dacryodes edulis</i>	-	<i>Cikcomophor palviflora</i>	-
<i>Irvingia gabonensis</i>	-	<i>Raubevia species</i>	-
<i>Pentaclethra macrophylla</i>	-	<i>Vigna ambascensis</i>	Papilionaceae
<i>Prosopis globiflora</i>	Mimosaceae	<i>Deterium senegalense</i>	-
<i>Vigna fischeri</i>	Papilionaceae	<i>Abelmoschus esculentus</i>	-
<i>Arisaema uluguruense</i>	Araceae	<i>Hibiscus sabdariffa</i>	Malvaceae
<i>Lasianthus cereiflorus</i>	Rubiaceae	<i>Solanum aethiopicum</i>	Solanaceae
<i>Neobenthamia gracilis</i>	Orchidaceae	<i>Corchorus olitorius</i>	-
<i>Garcinia semseii</i>	Guttiferae	<i>Gnetum africanum</i>	-
<i>Uncaria africana</i>	Rubiaceae	<i>Impatiens teitensis</i>	Balsaminaceae
<i>Gravesia riparia</i>	Melastomataceae		

Source: Own field data

APPENDIX 3. LIST OF PLANTS COMMONLY USED LOCALLY IN THE NGURU MOUNTAINS

Species name	Common name	Species name	Common name
<i>Isobertlinia scheffleri</i>	Mbarika/Mtambala	<i>Harungana madagascariensis</i>	Mkuntu
<i>Dracaena species</i>	Mnonge	<i>Bridelia micrantha</i>	Mkalakala
<i>Psychotria species</i>	Huvihuvi	<i>Vitex doniana</i>	Mgobwe/Mfuu
<i>Costus sarmentosus</i>	Tungalu	<i>Diplorynchus condylocarpon</i>	Mtogo
<i>Garcinia species</i>	Msambu mbitwe	<i>Brachystergia bohemii</i>	Myombo
<i>Alchornea species</i>	Zenga mkuku	<i>Manilkara sulcata</i>	Sesi
<i>Pauridianthus species</i>	Mfyonzo	<i>Dombeya cincinnata</i>	Mswayu
<i>Allophyllus abyssinica</i>	Mbangwe	<i>Acacia tanganyikensis</i>	Mgunga
<i>Allanblackia stuhlmanii</i>	Msambu/Mkimbo	<i>Sclerocarya birrea</i>	Mng'ong'o
<i>Entandrophragma stoltzii</i>	Mbokoboko	<i>Ocimum americanum</i>	Mfumbasi
<i>Cephalosphaera usambarensis</i>	Mtambara	<i>Hyptis suaveolens</i>	Nung'nung'a
<i>Annona toxicaria</i>	Mlulu	<i>Maurea triphylla</i>	Ududu
<i>Diospyros abyssinica</i>	Mweleka	<i>Croton species</i>	Mfurufuru
<i>Markharmia obtusifolia</i>	Lusui	<i>Terminalia species</i>	Mkungu
<i>Tamarindus indica</i>	Mkwazu/Ukwaju	<i>Tylosema fassoglensis</i>	Mbwala
<i>Jubelradia jubiflora</i>	Miombo	<i>Lannea cornuta</i>	Chunga
<i>Pterocarpus angolensis</i>	Mninga	<i>Corchorus olitorius</i>	Mienda
<i>Combretum species</i>	Mpera mwitu	<i>Acanthaceae species</i>	Mwitu
<i>Milicia excelsa</i>	Mvule	<i>Gynandropsis gynandra</i>	Mgange
<i>Parkia filicoidea</i>	Mkuntu	<i>Bidens pilosa</i>	Nyahwetsa
<i>Hagenia africana</i>	Mrosirose	<i>Justicia betonica</i>	Nzafe
<i>Ocotea usambarensis</i>	Mkulo	<i>Vigna unguiculata</i>	Kibungo
<i>Albizia species</i>	Mfuranju/Mkenge	<i>Azalia species</i>	Mkora
<i>Ceiba pentandra</i>	Msufi	<i>Talinum portulacastrum</i>	Tura
<i>Khaya anthotheca</i>	Mkangazi	<i>Amaranthus species</i>	Mkekomba
<i>Trema orientalis</i>	Ntambu	<i>Pennisetum purpureum</i>	Kologa
<i>Cassipourea malosana</i>	Nkazito	<i>Commelina species</i>	Ubwesi
<i>Newtonia buchananii</i>	Mnyasa	<i>Solanum species</i>	Tungule
<i>Cassipourea gummifera</i>	Nkazito	<i>Ricinus communis</i>	Mbarika
<i>Gyathia dregei</i>	Kunze	<i>Ensete ventricosum</i>	Mdzimwitu
<i>Catha edulis</i>	Mirungi	<i>Parinari curatellifolia</i>	Mula
<i>Khaya nyasica</i>	Mkangazi	<i>Flueggea virosa</i>	Kwambekwambe
<i>Strombosia scheffleri</i>	Msangana	<i>Grewia similis</i>	Mkola
<i>Trichilia emetica</i>	Mafura	<i>Strochynos innocua</i>	Mtonga
<i>Podocarpus milanjianus</i>	Msenamawe	<i>Haslundia opposita</i>	Ujoujo
<i>Arundinaria alpina</i>	Mwanzi	<i>Ximenia caffra</i>	Mpingi
<i>Filicahoa laurifolia</i>	Mkumba-shashi	<i>Flacourtia indica</i>	Ngola
<i>Millenia stuhlmanii</i>	Mpande/Pangapanga	<i>Annona senegalensis</i>	Mzang'we
<i>Mitragyna rubrostipulata</i>	Mromberombe/Mweleka	<i>Sorindeia madagascariensis</i>	Mkunguma
<i>Parinari excelsa</i>	Mula	<i>Berchemia discolor</i>	Nyahumbu
<i>Pygeum africanum</i>	Mkomaboyo	<i>Diospyros mespiliformis</i>	Msindanguruwe
<i>Sterculia appendiculata</i>	Mfume/mgude	<i>Ficus capensis</i>	Mkuyu
<i>Syzgium guineense</i>	Mschihui/Mzambarau	<i>Teclea nobilis</i>	Kilongolo

Source: Own field data

APPENDIX 4. SPECIES IN THE ZONE ADJACENT TO THE RAIN FOREST

Species enumerated in the zone adjacent to the rain forest	Family
<i>Harungana madagasacriensis</i>	Hypericaceae
<i>Costus sarmentosus</i>	Zingiberaceae
<i>Dracaena species</i>	Agavaceae
<i>Albizia gummifera</i>	Mimosaceae
<i>Bridelia micracantha</i>	Euphorbiaceae
<i>Myrianthus holstii</i>	Moraceae
<i>Celtis zenkeri</i>	Ulmaceae
<i>Hoslundia opposita</i>	Labiataeae
<i>Hallea rubrostipulata</i>	Rubiaceae
<i>Macaranga species</i>	Euphorbiaceae
<i>Newtonia buchananii</i>	Mimosaceae
<i>Entandrophragma stolzii</i>	Meliaceae
<i>Fagaropsis angolensis</i>	-
<i>Bombax rhodognaphalon</i>	Bombacaceae
<i>Antiaris toxicaria</i>	Moraceae
<i>Vitex doniana</i>	Verbenaceae
<i>Milicia excelsa</i>	Moraceae
<i>Acacia nigrescens</i>	Mimosaceae
<i>Strombosia scheffleri</i>	Olacaceae

Source: Own field data

APPENDIX 5. MAIN TREE SPECIES ENUMERATED ALONG RIVER/STREAM BANKS

Plant species name	Local/common name
<i>Milicia excelsa</i>	Mvule
<i>Albizia gummifera</i>	Mkenge
<i>Acacia nigrescens</i>	Mtambala
<i>Acacia xanthophloea</i>	Mtambala
<i>Harungana madagascariensis</i>	Mkuntu
<i>Newtonia buchananii</i>	Mnyasa
<i>Ficus capensis</i>	Mkuyu
<i>Ceiba pentandra</i>	Msufi
<i>Terminalia catalpa</i>	Mtagala/Mkungu

Source: Own field data

APPENDIX 6. SPECIES ENDEMIC AND NEAR-ENDEMIC IN THE TROPICAL RAIN FOREST OF THE NGURU MOUNTAINS.

Species	Family	Nature of plant
<i>Dionychastrum schliebenii</i>	<i>Melastomataceae</i>	<i>Shrub</i>
<i>Chlamydostachya spectabilis</i>	<i>Acanthaceae</i>	<i>2.4 m tree</i>
<i>Lobelia morogoroensis</i>	<i>Lobeliaceae</i>	<i>4-6 m tall plant</i>
<i>Lobelia lukwangulensis</i>	<i>Lobeliaceae</i>	<i>> 4 m tall plant</i>
<i>Lobelia sancta</i>	<i>Lobeliaceae</i>	<i>> 4 m tall plant</i>
<i>Saintpaulia pusilla*</i>	<i>Gesneriaceae</i>	<i>Herb</i>
<i>Amorphophallus stuhlmanii*</i>	<i>Araceae</i>	<i>2.5 m herb</i>
<i>Cyperuslongi involucratus</i>	<i>Cyperaceae</i>	<i>Sedge forming mats</i>
<i>Ixora tanzaniensis</i>	<i>Rubiaceae</i>	<i>Small tree</i>
<i>Polyceratocarpus scheffleri</i>	<i>Anonaceae</i>	<i>6-20 m tree</i>
<i>Lagynias pallidiflora</i>	<i>Rubiaceae</i>	<i>5-6 m tree</i>
<i>Streptocarpus species</i>	-	<i>Herb</i>
<i>Coffea canephora</i>	<i>Rubiaceae</i>	<i>Shrub</i>
<i>Anisophyllea obtusifolia</i>	<i>Rhizophoraceae</i>	<i>Giant forest tree</i>
<i>Urogenias uluguriga</i>	<i>Gentianaceae</i>	<i>Half-woody herb</i>
<i>Arisaema uluguruense</i>	<i>Araceae</i>	<i>Herb</i>
<i>Lasianthus cereiflorus</i>	<i>Rubiaceae</i>	<i>Shrub</i>
<i>Neobenthamia gracilis*</i>	<i>Orchidaceae</i>	<i>2 m shrub</i>
<i>Garcinia semseii*</i>	<i>Guttiferae</i>	<i>Tree</i>
<i>Uncaria africana*</i>	<i>Rubiaceae</i>	<i>Climber</i>
<i>Gravesia riparia*</i>	<i>Melastomataceae</i>	<i>Half-shrub</i>
<i>Danais xanthorrhoea*</i>	<i>Rubiaceae</i>	<i>Climber</i>
<i>Alligera madagascariensis</i>	<i>Hernandiaceae</i>	<i>Climber</i>
<i>Aloe schliebenii</i>	<i>Liliaceae</i>	<i>Tree</i>
<i>Cussonia lukwangulensis</i>	<i>Araliaceae</i>	<i>Tree</i>
<i>Impatiens teitensis</i>	<i>Balsaminaceae</i>	<i>Herb</i>

Footnote: * Specific for Nguru mountains. The rest are near endemic since some can also be found in some other "Eastern Arc" mountains of Tanzania for which they are endemic.

Source: P6cs (1990), Own field data (1993/94)

APPENDIX 7A
CLASSIFICATION OF INDIGENOUS HARDWOOD TREE SPECIES OF
OUTSTANDING COMMERCIAL VALUE

Source: Ministry of Tourism, Natural Resources and Environment. The Forest Ordinance (CAP 389), The Forest (Amendment) Rules, 1992. Government Notice No. 251.

<i>Botanical names</i>	<i>Trade and vernacular names</i>
	CLASS I
Dalbergia melanoxylon Diospyros ebenum/ mespiliformis	E. A. camphorwood mkulo mseri. Ehony
	CLASS II
—Combretum schumannii —Chlorophora excelsa Pterocarpus angolensis Millertia stuhmannii —Brachylaena hutachinsii —Olea welwitschii	Mperamwitu, mgurure, mkwaya, Mkongola, mvule, Iroko, Mninga Muninga panga-panga Muhuhu, Mhungwe, Mkarambaki Loliondo, Mchiyo, Msbisho.
	CLASS III
Adina microcephala Afzelia quenzensis Fagaropsis angolensis Juniperus procera Khaya nyasica Morus lactea Ocotea usambarensis Pterocarpus all species Warburgia stuhlmannii Entandrophragma all spp Olea africana Olea hochstetteri Cephalosphaera usambarensis Sandal wood	Adina, Mguasia, Mdogowe, Mgwina Afzelia, Mkora, Mkongo Mafu, Mfu, Mtua, Kunguni Cedar, Mkarakwa, Mwangati, African mahogany, mkangazi, Mwawamiovu. E. A. mulberry, kumbu, Mkuza- funta E. A. camphorwood mkulo mseri, muhcti, msiwisiwi, maasi, muwong. Mkula, magubi, Mtumbati-mtoni Mkurungu. Mlifu, Mkarambati, E.A. greenheart Mric, Mongo Muwumbu, Mkalikali Mbokoboko. Brown olive, Alorion Mzira, Gembe, Menefu, mtuamisi. E. A. olive, ngwe, Mwalambo, mtagala, Mkimbamkubwa Mtambara, mtambaa Msandali.

APPENDIX 7A (continued)

CLASSIFICATION OF INDIGENOUS HARDWOOD TREE SPECIES OF
OUTSTANDING COMMERCIAL VALUE

Source: Ministry of Tourism, Natural Resources and Environment. The Forest Ordinance (CAP 389), The Forest (Amendment) Rules, 1992. Government Notice No. 251.

CLASS IV

Albizia glabrescens	Mfurangi
Albizia versicolor	Mtanga, Mvimbafura, Mukingu
Baphia kirkii	Mdurasi
Beilschmiedia kweo	Mkuruti
Brachystegia spiciformis	Mbambakofi, Mfimbo, Mkweco
Cassipoures malosana	Mtundu
Ficalhoa laurifolia	Pillarwood, Ndiri, Msadora,
Grevillea robusta	Mscngera, Nkazito
Macropsis emini	Ficalhoa, Isete, Mkuka
Cordyla africana	Mgenusi, Ndrenu
Lovoa brownii	grevillea
Lovoa swynnertonii	Musizi, Muhumula, Musika
Podocarpus all spp.	Cordyla, mroma, mgwata
Hagenia abyssinica	Nkoba, Msau, Mukusu
Swartzia madagascariensis	Nkoba, Msau, Mukusu
	Podo, msc, musisimu, mtokosi
	mvavavi, nyarurasi, nakini.
	Hagenia, mwanga, luziluzi
	Pau rose, Kassinda, <i>mg'enje</i> .

CLASS V

Albizia gumnifera	Omulera, mshai, mboromoro,
Albizia antunesiana	mhenge
Albizia schimperiana	Ngando, Muvura, Mgando-kagua
Chrysophyllum-all spp	Msangala,
Cordiz abyssinica	Mfuranji, Mruka
Diospyros-all spp	Mululu, Mgoŋa, Mulembecembe
Ekerbergia rupeelliana	mberimber
Erythrophleum guinense	Mkumasi, Mringaringa,
Faurca-all spp.	Musingati,
Manikara all spp.	Msui, ol guradien, msambu
Newtonia-all spp.	mkadi, msidi, Mgiriti
Newtonia-paucijuga	Ekerbergia, Msisi ol Mikumo
Parinari excelsa	Tiwe, Msimbi
Rapanea rhododendroides	missanda, muavi, mkarati
	Mifuka, msisi, lisega
	Mkunya mgambo
	newtonia, mkufi, mpunga,
	mnyasa miomereza lakiaka
	Mshashita, mdadalika
	muhula, mule, msabula
	rapanea, mlimangombe,
	mshiwizo, kidongashawa mwasa

CLASS VI

All trees species not listed in the preceding classes:

APPENDIX 7B
CLASSIFICATION OF INDIGENOUS HARDWOOD TREE SPECIES OF
OUTSTANDING COMMERCIAL VALUE

Source: Ministry of Tourism, Natural Resources and Environment. The Forest Ordinance (CAP 389), The Forest (Amendment) Rules, 1993. Government Notice No. 265 of 24.12.1993.

CLASS	BOTANICAL NAME	TRADE AND VERNACULAR
CLASS I A	<i>Dalbergia melanoxylon</i>	E.A. Blackwood, mpingo mugembe
	<i>Diospyros ebenum/mespiliformis</i>	Ebony, mgiriti, maindi mnumbulu mkulvi
	<i>Combretum schumanii</i>	Mpera mwitu, mguruwe, mkwaya
CLASS I B	<i>Milecea excelsa</i>	Mvule, mkongola, Iroko
	<i>Pterocarpus angolensis</i>	Mninga
	<i>Pterocarpus all species</i>	Mkula, mngubi mtumbati- mtoni, mkurungu
	<i>Millettia Stuhmanii</i>	Pangapanga
	<i>Brachylaena hutchinsii</i>	Muhuhu, mhungwe, mkarambati
	<i>Olea Welwitschii</i>	Loliondo, mchiyo, mshisho
	<i>Olea africana</i>	Brown olive, alorien mzira
	<i>Olea hotchistetteri</i>	E.A. Olive, ngve mwalambo, mkimbakubwa, mtegela.
	<i>Fagaropsis angolensis</i>	Mtua, mkunguni mtongoti
	<i>Khaya nyasica</i>	Mkangazi, mwavamiovu
	<i>Ocotea usamberensis</i>	Casphorwood, mkulo mserimuheti maasi
CLASS II A	<i>Adina microcephala</i>	Adina mgusia, mdogowe, mgwina.
	<i>Azelia quenzensis</i>	Azelia, mkora, mkongo mafu, mfu mbambakofi
	<i>Juniperus procera</i>	Pencilceder, mtarakwa mwangati,
	<i>Morus lactea</i>	E.A. mulberry, kumbu, mkuzafunta.
	<i>Filicalhoa laurifolia</i>	Filicalhoa, Isete, mkuta
	<i>Entandophragma all spp.</i>	Mrie, mongo, muwumbu mbokoboko, mkalikali
	<i>Cephalosphaera usambarensis</i>	mtambara, mtambaa
	Sandal wood (<i>osyris santallum</i>)	Msandali
	<i>Swartzia madagascarensis</i>	Paurosa, kasanda, meekeseke
CLASS II B	<i>Albizzia glabrescens</i>	mfurangi
	<i>Albizzia versicolor</i>	Mtanga, mvimbafura mukingu mdurasi
	<i>Baphia kirkii</i>	Baphia, mkuruti, mkaranga
	<i>Beilschmeidia kweo</i>	Mkimbo, mkweo, mkanta
	<i>Brachystegia spiciformis</i>	Mtundu
	<i>Casipourea malosana</i>	Pillar wood, ndiri, meedora
	<i>Podocarpus all spp</i>	Podo, mee, musisimu mtokosi
	<i>Hagenia abyssinica</i>	Hagenia, mwanga, luziluzi.
	<i>Lovoa brownii</i>	Mkoba (Uganda Walnut) msau, mukusu
	<i>Lovoa swynnertonii</i>	Msau, Kilimanjaro mahogany

APPENDIX 8 . RANGE OF USES RECORDED FOR VARIOUS PLANT AND ANIMAL SPECIES IN THE NGURU MOUNTAINS

Appendix 8.1 . Species for fuelwood (firewood and charcoal)
Source: Own field data

Botanical name	Local name
<i>Albizia species</i>	Mfuranji/Mkenge
<i>Trema orientalis</i>	-
<i>Ceiba pentandra</i>	-
<i>Lanthiathus speies</i>	-
<i>Begonia species</i>	-
<i>Soriendeia species</i>	-
<i>Erythophloem species</i>	-
<i>Cilcomophor parviflora</i>	-
<i>Raubevia species</i>	-
<i>Harungana madagascariensis</i>	Mkuntu
<i>Parkia filcoidea</i>	-
<i>Hagenia africana</i>	Mrosirose
<i>Arundinaria alpina</i>	Mwanzi
<i>Bridelia micrantha</i>	Mkalakala
<i>Allophyllus abyssinica</i>	Mbangwe
<i>Caussipourea gummifera</i>	Nkazito
<i>Faurea speciosa</i>	-
<i>Combretum molle</i>	Mpera mwitu
<i>Acacia nigrescens</i>	Mtambala
<i>Flacourtia indica</i>	-
<i>Syzygium guinense</i>	Mzambarau
<i>Vitex doniana</i>	Mgwobe
<i>Isorberlinia tomentosa</i>	Mtambala
<i>Manilkara sulcata</i>	-

Appendix 8.2 . Species for local medicine

Source: Own field data

Botanical name	Local name
<i>Piliostigma thonongii</i>	-
<i>Erythrina abyssinica</i>	-
<i>Randia taylorii</i>	-
<i>Combretum species</i>	Mpera mwitu
<i>Sclerocarya birrea</i>	Mng'ngo
<i>Ocimum americanum</i>	Mfumbasi
<i>Hyptis suaveolens</i>	Nung'nung'a
<i>Maerua triphyla</i>	Ududu
<i>Flacourtia indica</i>	-
<i>Gardenia jovis-tonantis</i>	-
<i>Rhus vulgaris</i>	-
<i>Croton species</i>	Mfurufuru
<i>Ximenia americana</i>	-
<i>Albizia antunesiana</i>	Mkenge
<i>Acacia tanganyikensis</i>	Mgunga
<i>Terminalia sericea</i>	Mkungu
<i>Multidentia crassa</i>	-

Appendix 8.3 . Species for vegetables

Source: Own field data

Botanical name	Local name
<i>Laurnea cornuta</i>	Chunga
<i>Corchorus species</i>	Mlenda
<i>Acanthaceae species</i>	Mwidu
<i>Gynandropsis gynandra</i>	Mgange
<i>Bidens pilosa</i>	Nyahwetsa
<i>Vigna unguiculata</i>	Nzafe
<i>Ancylobothyrs petersiana</i>	Kibungo
<i>Talinum portulacastrum</i>	Tele
<i>Solanum incunum</i>	Tura/Mungusilwalwa
<i>Justice species</i>	Mkekomba
<i>Amaranthus species</i>	Ubwesi
<i>Commelina species</i>	Kologa

Appendix 8.4. Species for wild fruits
Source: Own field data

Botanical name	Local name
<i>Parinari curatellifolia</i>	Mula
<i>Syzygium guineense</i>	Mzambarau
<i>Flueggea virosa</i>	Kwambekwambe
<i>Manilkara sulkata</i>	Sesi
<i>Grewia similis</i>	Mkole
<i>Sclerocarya birrea</i>	Mng'ongo
<i>Strychnos innocua</i>	Mtonga
<i>Hoslundia opposita</i>	Ujoujo
<i>Ximenia caffra</i>	Mpingi
<i>Flacourtia indica</i>	Ngola
<i>Annona senegalensis</i>	Mzang'we
<i>Sorindeia madagascariensis</i>	Mkunguina
<i>Berchemia discolor</i>	Nyahumbu
<i>Vitex doniana</i>	Mfuu
<i>Diospyromis mespiliformis</i>	Msindanguruwe
<i>Trichilia emetica</i>	Mfuru/Mafura
<i>Allanblackia stuhlmanii</i>	Mkimbo
<i>Ficus capense</i>	Mkuyu
<i>Faurea speciosa</i>	-

Appendix 8.5. Species for seed and nuts
Source: Own field data

Botanical name	Local name
<i>Tylosema fassoglensis</i>	Mbawala
<i>Allanblackia stuhlmanii</i>	Mkimbo
<i>Trichilia emetica</i>	Mafura/Mfuru
<i>Diplorhynchus condylocarpon</i>	-

Appendix 8.6. Species for sap and gums
Source: Own field data

Botanical name	Local name
<i>Diplorhynchus condylocarpon</i>	Mtogo

Appendix 8.7 . Species for hanging and making beehives .

Source: Own field data

Botanical name	Local name
<i>Brachystergia boehmii</i>	Myombo
<i>Manilkara sulcata</i>	Sesi
<i>Milicia excelsa</i>	Mvule
<i>Dombeya cincinnata</i>	Mswayu
<i>Protea chionantha var. divaricate</i>	-
<i>Acacia tanganyikensis</i>	Mgumga

Appendix 8.8 . Species for timber, handicraft and furniture

Source: Own field data

Botanical name	Local name
<i>Milicia excelsa</i>	Mvule
<i>Newtonia buchananii</i>	Mnyasa
<i>Entandrophragma stolzii</i>	Mbokoboko
<i>Khaya nyasica</i>	Mkangazi
<i>Ocotea usambarensis</i>	Mkulo
<i>Cephalosphaera usambarensis</i>	Mtambara
<i>Pterocarpus angolensis</i>	Muninga
<i>Podocarpus milanjanus</i>	Msenamawe

Appendix 8.9 . Animal, Bird and insect species used for food

Source: Own field data

English name	Local name
Buffalo	Nyati
Antelope	Paa
Rabbit	Sungura
Bush pig	Ngiri (Nguruwe mwitu)
Guinea fowl	Kanga
Dik dik	Digidigi
Winged termites	Kumbikumbi
Long-horned grasshopper	Senene

APPENDIX 9

LIST OF RESERVED TREES IN TANZANIA

Source: Ministry of Tourism, Natural Resources and Environment. The Forest Ordinance (CAP 389).

Item No.	Botanical name	Trade name
1	<i>Milicia excelsa</i>	Mvule
2	<i>Pterocarpus angolensis</i>	Muninga
3	<i>Dalbergia melanoxylon</i>	Mpingo
4	<i>Khaya species (all)</i>	Mkangazi
5	<i>Azelia quanzensis</i>	Mkora
6	<i>Belschmedia kweo</i>	Mfimbo
7	<i>Brachylaena hutchinsii</i>	Muhungwe
8	<i>Osyris species (all)</i>	Msandati
9	<i>Cephalosphaera usambarensis</i>	Mtambara
10	<i>Juniperus procera</i>	Mwangati
11	<i>Olea welwitschii</i>	Loliondo
12	<i>Adina microcephala</i>	Mgurua
13	<i>Ocotea usambarensis</i>	Mkulo
14	<i>Millettia stuhlmanii</i>	Pangapanga
15	<i>Podocarpus usambarensis</i>	Podo
16	<i>Trichilia roka</i>	Mafura
17	<i>Allanblackia stuhlmanii</i>	Mkimbo
18	<i>Catha edulis</i>	Mirungi

List prepared in 1987.

**SOCIO-ECONOMIC ANALYSIS OF DEFORESTATION OF TROPICAL
RAINFORESTS AS A CONSEQUENCE OF AGRICULTURE PRODUCTIVITY,
RISKS AND POPULATION GROWTH: A CASE STUDY OF MHONDA VILLAGE IN
THE NGURU MOUNTAINS, TANZANIA**

REPORT NUMBER 3

ABSTRACT

This is a study to analyze possibilities for sustainable landuse management at household farm level in order to preserve the tropical rainforest in the Nguru mountains, Tanzania. Based on welfare theory, the theory of household economy and mathematical programming, farm and forest management data collected in Mhonda village during the period 1993-94 were used to analyze deforestation pressure as a consequence of agriculture production, risks in farming and population growth. A multi-objective compromise farm planning model for an average household was developed and used to investigate conflict and compromise among a vector of three competing objectives namely: maximization income, minimization of risk, and minimization of labour use variation. It was designed and used to generate and evaluate efficient farm plans for the farmer. The model allocates resources among 18 crop production activities. A pay-off matrix containing efficient but unattainable solution was generated using vector optimization technique. A set of compromise solutions was then obtained for the objectives. Results showed that the existing farm plan is inferior when compared with the compromise farm plans generated by the model. Consequently modest gains in crop output and cash income could be achieved by resource re-allocation such as by eliminating some monoculture cropping enterprises and expanding mixed cropping patterns which are beneficial in risk aversion, labour use distribution and replenish soil fertility. By concentrating on only a few profitable crops returns were found to increase. More gains could be realized if farming technology was transformed to improve the traditional methods of production. The current level of technology was found to be an impediment to full employment of resources. Improved technologies are however limited by lack of capital to cover the high costs involved in transforming agriculture which could benefit forest lands. Lack of capital limits the way labour and land are utilized. Removal of institutional impediments, increased use of inputs, motivation by price incentives and improved marketing are essential steps to boost output and reduce deforestation pressure. The study results further showed that the present farming systems are unsustainable in the long term because they can sustain the present population growth rate of about 2.6% per year for only a maximum duration of between 10 and 15 years, which is far shorter than one human generation. Forest encroachment for agriculture was one main cause of deforestation pressure. Declining crop productivity and income due to diminishing soil fertility under conditions of growing food demand due to population growth seemed to be important driving forces behind encroachment which causes deforestation. Most of the new land clearing seemed to be carried out by marginalized households owning small farmholdings thus most concerned with expanding their farmholdings since it was most profitable to do so. At higher population growth rates deforestation rate was higher than at lower population growth rates. Perceived decreasing risk levels in farming also promoted deforestation. An increase in fertilizer prices, promoted poor landuse practices and increased the need for opening up new lands in order to compensate for loss in fertility and maintain yield levels. This increased deforestation pressure. Lack of inputs mainly tools and labour decreased the need for opening up new lands but also caused adoption of poor landuse practices. By adopting compromise efficient farm plans farmers could improve their income and savings and this could lead them to adopt appropriate landuse practices which could have positive impact in reducing deforestation pressure.

Key words: Agriculture, peasants, income, risk, population growth, tropical rainforest, deforestation, landuse planning, mathematical programming, compromise programming.

ACKNOWLEDGEMENT

This report is a product of the invaluable assistance, advice, criticism, suggestions and information from various individuals and institutions in their various capacities. NORAD's financial support for this study is highly appreciated. I am also highly indebted to the Department of Forest Sciences at Aas for logistical support during my stay at AUN, and also to the Department of Forest Economics and the Faculty of Forestry, Dean'S Office at SUA for logistical support during field work in Tanzania.

Prof. Dr. Birger Solberg of the Norwegian Forestry Research Institute (NISK) initiated, inspired and diligently guided me throughout this study. Dr. Prem Sankhayan, Senior Economist, Centre for International Environment and Development Studies-NORAGRIC, provided valuable literature on modeling and also introduced me to the GAMS Software and its application. His encouragement and practical support is highly appreciated. Dr. A.R.S. Kaoneka of the Department of Forest Economics SUA, introduced me to modeling and compromise programming. His earlier modeling work served as a useful guidance to me.

Peasant farmers, local leaders and government agents in Mhonda village devoted their time to respond to continuous interviews throughout the year and allowed us sometimes to pry into their privacy. Their cooperation is highly appreciated. The village leadership under the then village Chairman Mr. Ferdinand N. Kabelwa deserve special gratitude for arranging and facilitating the interviews, field observations and providing village data.

Messrs. A.S. Kigona, E.F. Mazengo, C.O.B.Z. Jamal, D. Mwaikenda and Kimu conducted the interviews and field observations. Their endurance during field visits facilitated success of data collection. Mr. Y. M. Ngaga assisted in the preliminary survey of Mhonda village and was available for relevant discussions during write up of this report. Government offices at District and Regional level, the Morogoro Region Cooperative Union, the Marketing Development Bureau and the Bureau of Statistics DSM, provided valuable assistance.

To all these individuals and institutions including those not mentioned here, I am deeply thankful.

TABLE OF CONTENTS

ABSTRACT	(ii)
ACKNOWLEDGEMENT	(iii)
TABLE OF CONTENTS	(iv)
LIST OF TABLES	(ix)
LIST OF FIGURES	(xi)
LIST OF APPENDICES	(xi)
LIST OF ACRONYMS	(xii)
1.0 INTRODUCTION	1
1.1 Role of agricultural landuse practices in ecological degradation in Tanzania	1
1.2 Ecological degradation in Tanzania's catchment forests and the need to protect the tropical rainforest in the Nguru mountains	2
1.3 Objectives and main hypothesis of the study	3
1.4 Study outline and main limitations	4
1.4.1 Study outline	4
1.4.2 Limitations of the study	6
2.0 LITERATURE REVIEW	7
2.1 Some theoretical aspects on rural development, peasant agriculture, peasant household economics, mathematical programming and application	7
2.1.1 Nature of the problem of poverty in rural areas	7
2.1.2 The concept of rural development	8
2.1.3 Strategies for rural development	8
2.1.4 Why peasant farmers may oppose rural development programmes	10
2.1.5 Rural development policy in Tanzania	11
2.1.6 Land use planning as a tool for sustainable resource management in Tanzania	12
2.1.7 Land use planning at farm enterprise level	13
2.1.8 Peasant agriculture	14
2.1.8.1 Its Rationality and relevance	14
2.1.8.2 Review of theories on efficiency and transformation of peasant agriculture	17
2.1.8.3 Theories and models on peasant agriculture transformation	18
The conservation model	18
The urban-industrial impact model	19
The Diffusion model	19
The high pay-off input model	20
The induced development model	20
2.1.8.4 Boserup's model: population increase and technology	22
2.1.8.5 Economic strategies for agricultural development	24
2.1.9 Review of peasant household economics and its application	25
2.1.9.1 Background of peasant household economics	25
2.1.9.2 The neo-classical theory of farm production	26
Theory of the farm firm	26

	The production function: use in farm decision making and limitations	26
	Concepts on behaviour and main features of peasants	27
	The theory of optimizing peasants	30
	The theory of profit maximizing peasant	30
	The theory of the risk-averse peasant	31
	Theory of the drudgery-averse peasant (Welfare maximization)	32
	The Chayanov farm household model	32
	The farm household peasant: households decisions with labour market	34
	The new home economics theory (Welfare maximization)	36
	The theory of sharecropping peasant	36
2.1.9.3	Comparison of the alternative theories and relevance to this study	37
2.1.9.4	Relevance of the household economic theory in analyzing peasant behaviour	38
2.1.9.5	Complexity of peasant agricultural sector analysis	38
2.1.9.6	The multi-objective criteria in planning peasant farming systems	40
2.1.9.7	Context of peasant decision making and farm planning models	41
2.1.10	Mathematical programming in peasant agriculture planning	42
2.1.10.1	Assumptions underlying the LP model	42
	Linearity and additivity assumption	42
	The divisibility assumption	43
	The deterministic assumption	43
	Fixed technology assumption	43
	Non-negativity assumption	44
2.1.10.2	Why LP is used in farm planning	44
2.1.11	Review of multiple objective programming (MOP)	44
2.1.11.1	Introduction	44
2.1.11.2	Multiple objective programming framework	45
2.1.11.3	Compromise programming application	46
2.1.12	Review of non-linear programming (NLP) model	51
2.1.12.1	Theory of quadratic programming approach	51
2.1.12.2	Assumptions underlying the quadratic programming model	51
2.1.12.3	Definition of the quadratic programming model for farm planning	53
2.1.12.4	Data requirements of the quadratic programming model	54
2.1.12.5	Standard estimation procedure of gross margins and income variance for the quadratic programming model	54
2.1.12.6	Attractiveness of E-V criterion of the quadratic programming model	55
2.1.13	Review of risk analysis in peasant agriculture planning	56
2.1.13.1	Risk and uncertainty in peasant agriculture	56
2.1.13.2	Approaches for risk analysis in peasant agriculture planning	58
2.2	Literature on some previous studies based on the application of peasant household economic theory and mathematical programming	60
2.3	Cost-benefit analysis in peasant farming	67
3.0	METHODOLOGY AND DATA	69
3.1	Socio-economic survey	69

3.1.1	Description of the study area	69
3.1.2	Method of sampling	71
3.1.2.1	Why a Case Study Approach was chosen for this study	72
3.1.3	Data acquisition	73
	Physical and ecological data (biophysical data)	76
	Socio-economic data	76
	Landuse data	76
	Resources and local level supporting system data	77
	Policies, institutional supporting services and general macroeconomic data	77
3.2	The mathematical programming model	78
3.2.1	Theory, hypothesis, basic assumptions and plan of the model	78
3.2.2	Model description and data	81
3.2.2.1	Definition of cropping systems and crops grown in Mhonda village	81
3.2.2.2	Definition of the decision variables for the model	82
3.2.2.3	Crop production activities	82
3.2.2.4	Purchase activities	82
3.2.2.5	New land clearing activities	82
3.2.2.6	Crop consumption activities	83
3.2.2.7	Right Hand Side (RHS) values for the constraints	83
3.2.2.8	Technical input-output coefficients for the mathematical model	84
3.2.2.9	Generalized detached coefficient matrix for the model	84
3.2.2.10	Definition of objective functions	84
3.2.2.11	Definition of constraints for the model	86
	Labour constraint	86
	Fertilizer requirements	86
	Nitrogen nutrient constraint	87
	Phosphorus nutrient constraint	87
	Manure requirement constraint	88
	Working capital constraint	88
	Capital limit constraint	89
	Food allocation constraints	89
	Food allocation constraint for maize	90
	Food allocation constraint for beans	90
	Food allocation constraint for cassava	91
	Food allocation constraint for rice	91
	Food allocation constraint for sorghum	92
	Food allocation constraint for vegetables	92
	Food allocation constraint for banana	93
	Food allocation constraint for fruits	93
	Food allocation constraint for minor crops	93
3.2.2.12	Land area constraint	94
3.2.2.13	Non-negative restrictions	95
3.2.2.14	The detached coefficient matrix for the model inputs	95
3.2.2.15	Optimization and sensitivity analysis	95

3.2.2.16	Analysis of impact of agriculture on deforestation pressure	96
	Impact of changes in total land area and food consumption due to population growth	96
	Impact of price changes on total net income (farmer's gross margin)	98
	Effect of changes of total working capital on the use of resources and deforestation	98
	Effect of increasing fertilizer price on deforestation	98
	Experimentation and sensitivity analysis with stochastic variables	99
4.0	RESULTS AND DISCUSSIONS	101
4.1	Survey results and discussions	101
4.1.1	Input resource availability, utilization and productivity	101
4.1.1.1	Land availability and utilization	101
	Land tenure system	101
	Farm layout, size and distribution of holdings	105
4.1.1.2	Labour supply and demand	105
	Demographic data in Mhonda village	105
	Household labour supply and demand, timing of operations and agricultural calendar	105
	Monthly labour allocation and requirement in Mhonda village	110
	Household dependency (producer to consumer) ratio in Mhonda village	113
4.1.1.3	Capital resources available	113
4.1.1.4	Entrepreneurship or management input in farm activities in Mhonda village	116
4.1.1.5	Household farm output and resource productivity	118
4.1.1.6	Summary of per hectare resources availability, utilization and productivity for a household farm in Mhonda village	121
	Gross returns and margins for a peasant farm household in Mhonda village	121
	Returns to factors of production	127
4.1.1.7	Concluding remarks on micro-economic analysis	133
4.2	Model analysis results and discussions	133
4.2.1	Results of the basic model (Optimization results)	133
4.2.1.1	Pay-off matrix and ideal farm plan of an average household in Mhonda village	133
4.2.1.2	Compromise farm plan for an average household in Mhonda village	134
4.2.1.3	Analysis of the solution: Comparison of the existing and compromise farm plans	136
	Objective function values	136
	Land allocation, cropping pattern, fertilizer use and food consumption	137
	Labour utilization	138
	Working capital effect on other factors of production and deforestation	141
	Resources and their shadow prices and impact on deforestation	142

	Risk aversion by households and impact on land use and forest encroachment	145
	Potential for cash crop production in Mhonda village	146
4.2.2	Results of sensitivity analysis	146
4.2.2.1	Impact of population growth on deforestation	146
4.2.2.2	Cost-benefit analysis of farm expansion by clearing new land (deforestation) as a result of population growth	152
4.2.2.3	Impact of population growth on total net income	154
4.2.2.4	Impact of price changes on deforestation pressure	154
4.2.2.5	Price elasticity of crops and deforestation	157
4.2.2.6	Effect of changes of total working capital supply on resources use and deforestation	158
4.2.2.7	Effect of increasing fertilizer prices on deforestation pressure	161
4.2.2.8	Stochastic analysis of optimum farm plans in Mhonda village	163
	Effect of risk aversion on deforestation	163
5.0	OVERALL DISCUSSIONS AND CONCLUSIONS	167
5.1	Resource availability consequences under the existing farming practices	167
5.1.1	Land supply and its effects and deforestation	167
5.1.2	Capital supply effect and deforestation	169
5.1.3	Labour supply effects and deforestation	170
5.2	Impact of land use practices on deforestation	171
5.3	Returns and profitability of cropping patterns	172
5.4	Population growth and sustainability of existing farming systems	173
5.5	Effect of risk aversion and labour use variability on land use pattern and deforestation	173
5.6	General concluding remarks and policy implications of the study results	174
	REFERENCES	179
	APPENDICES	192

LIST OF TABLES

Table 2.1	Main features of the various theories of peasant economic behaviour	37
Table 2.2	A hypothetical pay-off matrix for a typical MOP problem with two objectives	47
Table 2.3	A hypothetical set of solutions for the CP model	50
Table 3.1	Generalized format of the detached coefficient matrix for the model	85
Table 3.2	Different scenarios and subjective weights used for sensitivity analysis with stochastic models	99
Table 4.1	Methods used to acquire land for farming in Mhonda village	103
Table 4.2.	Methods for acquisition of additional land in Mhonda village	103
Table 4.3	Participation of household members in various activities	107
Table 4.4	Agricultural calendar by crop for Mhonda village	108
Table 4.5	Agricultural calendar by operation (activity) for Mhonda village	109
Table 4.6.	Per hectare labour demand by crop and by activity in one season in Mhonda village	111
Table 4.7	Respondent's ranking of peak or busiest months in Mhonda village	111
Table 4.8	Calculation of adult-equivalent mandays available per month for a typical household in Mhonda village	112
Table 4.9	Monthly labour requirement per hectare for crops under monocropping system in Mhonda village (ME-mandays)	114
Table 4.10	Monthly labour requirement per hectare for crops under mixed cropping system in Mhonda village (ME-mandays)	114
Table 4.11	Monthly labour requirement per hectare for crops under multiple cropping system in Mhonda village (ME-mandays)	115
Table 4.12	Total monthly labour requirement per hectare for crops under all cropping system in Mhonda village (ME-mandays)	116
Table 4.13	The per hectare total labour supply versus labour demand in adult-equivalent mandays per month in Mhonda village	117
Table 4.14	Capital equipment owned per farm household in Mhonda village	118
Table 4.15	A summary of average crop yield levels for various cropping systems in Mhonda village	119
Table 4.16	Official (government) estimates of crop yield levels for various crops in Morogoro region	120
Table 4.17	Price list for various crops grown in Mhonda village	121
Table 4.18	Calculation of gross returns and margins for the major crops grown under monoculture cropping system in a peasant household farm in Mhonda village (T.Shs. in 1994 prices)	122
Table 4.19	Calculation of gross returns and margins for the major crops grown under mixed cropping system in a peasant household farm in Mhonda village (T.Shs. in 1994 prices)	123
Table 4.20	Calculation of gross return and margins for the major crops grown under	

	mixed cropping system in a peasant household farm in Mhonda village (T.Shs. in 1994 prices)	124
Table 4.21	Calculation of gross return and margins (T.Shs. in 1994 prices) for the major crops grown under multiple cropping system in a peasant household farm in Mhonda village	126
Table 4.22	Summary of resources availability, utilization and productivity per hectare for crops under monoculture cropping system for a typical household farm in Mhonda village	127
Table 4.23	Summary of resources availability, utilization and productivity per hectare for crops under mixed cropping system for a typical household farm in Mhonda village	128
Table 4.24	Summary of resources availability, utilization and productivity per hectare for crops under multiple cropping system for a typical household farm in Mhonda village	129
Table 4.25	Calculation of returns to factors of production for crops under monoculture cropping system in a household farm in Mhonda village	130
Table 4.26	Calculation of returns to factors of production for crops under mixed cropping system in Mhonda village	131
Table 4.27	Calculation of returns to factors of production for crops under multiple cropping system in Mhonda village	132
Table 4.28	Pay-off matrix and ideal point for the optimal farm plan of an average household in Mhonda village	134
Table 4.29	Compromise farm plans and the existing farm plan for an average household in Mhonda village	135
Table 4.30	Monthly labour supply and utilization in the existing and compromise farm plans (ME-mandays)	139
Table 4.31	Shadow prices for crops and limiting resources in the existing and compromise farm plans (T.Shs./ha)	144
Table 4.32	Optimum farm plans for an average household at a population growth rate of 2.6 % for 35 years	149
Table 4.33	Optimum farm plans for an average household at a population growth rate of 3.5 % for 35 years	151
Table 4.34	Cost-Benefit analysis of farm expansion by clearing new land in Mhonda village over a 35 year period (T.Shs.)	153
Table 4.35	Results of sensitivity analysis to test the impact of price changes on model results	156
Table 4.36	Optimum farm plans when total working capital and land area are varied for an average household in Mhonda village	160
Table 4.37	Optimum farm plans for a household in Mhonda village when fertilizer price is increased	162
Table 4.38	Compromise farm plans corresponding to L_1 metric when objective weights are varied for a farm household in Mhonda village	164
Table 4.39	Compromise farm plans corresponding to L_2 metric when objective weights are varied for a farm household in Mhonda village	165

Table 4.40	Compromise farm plans corresponding to L_{∞} metric when objective weights are varied for a farm household in Mhonda village	166
------------	---	-----

LIST OF FIGURES

Figure 2.1	The classification of farms as presented by Nakajima (1965)	15
Figure 2.2.	Boserup's virtuous circle showing the relationship between food supply, population change and technology	24
Figure 2.3	Indifference curve analysis of the choice between leisure and income	33
Figure 2.4(a)	Farm household "hiring in" labour	35
Figure 2.4(b)	Farm household "hiring out" labour	35
Figure 2.5.	A causal diagram showing the complexity of semi-subsistence peasant agricultural systems in Tanzania	39
Figure 2.6	Trade-off curve showing the trade-off between objectives in the CP model	50
Figure 2.7	The optimal E-V farm plan (an illustration)	52
Figure 2.8	Graphical presentation of Nakajima's subjective equilibrium theory in utility and income space	62
Figure 2.9	Graphical presentation of Nakajima's subjective equilibrium theory in utility and labour space	62
Figure 3.1.	Location of the study area	69

LIST OF APPENDICES

Appendix 1	Sample questionnaire for household and village survey
Appendix 2	Illustration of cropping patterns for an average household farm holding in Mhonda village
Appendix 3	Covariance matrix of variables: Income
Appendix 4	Covariance matrix of variables: Labour use variation
Appendix 5	Detached coefficient matrix of variables for the model
Appendix 6	Data input file for the GAMS model
Appendix 7	Time line analysis for Mhonda village
Appendix 8	Review of the Linear Programming model

LIST OF ACRONYMS

AICC	Arusha International Conference Centre
AUN	Agricultural University of Norway
CAP	Chapter in the Tanzania Statute (Law) Book
CBA	Cost Benefit Analysis
CCM	Chama Cha Mapinduzi (Tanzania's Ruling Party)
CMB	Cassava Mealy Bug
CP	Compromise Programming
EIU	Economist Intelligence Unit
FAO	Food and Agriculture Organization
GAMS	General Algebraic Modeling System
GDP	Gross Domestic Product
GIS	Geographic Information System
GM	Gross margin
IDRC	International Development Research Centre
IMF	International Monetary Fund
IUCN	International Union for Conservation of Nature
kcal	kilocalorie
LP	Linear Programming
LRDC	Land Resources Development Centre
MDB	Marketing Development Bureau
ME	Man-equivalent
ML	Minimization of labour use variation
MFC	Marginal Factor Cost
MNRSA	Management of Natural Resources and Sustainable Agriculture
MOP	Multi-objective Programming
MPP	Marginal Physical Product
MRCU	Morogoro Region Cooperative Union
MR	Minimization of Risk
MRS	Marginal Rate of Substitution
MVP	Marginal Value Product
NAP	National Agriculture Policy
NBC	National Bank of Commerce
NCSSD	National Conservation Strategy for Sustainable Development
NEAP	National Environmental Action Plan
NFI	Net Farm Income
NLP	Non Linear Programming
NORAD	Norwegian Agency for International Development
NORAGRIC	Norwegian Centre for International Agricultural Development
NPV	Net Present Value
OLP	Ordinary Linear Programming
REA	Risk Efficiency Analysis
RHS	Right Hand Side

RPFb	Rolling Plan and Forward Budgeting
SD	Standard Deviation
SDI	Standard Deviation of Income
SDL	Standard Deviation of Labour
TFAP	Tanzania Forestry Action Plan
TR	Total Revenue
T.Shs.	Tanzania Shillings
URT	United Republic of Tanzania
USA	United States of America
WCED	World Commission on Environment and Development
WHO	World Health Organization

METRIC UNITS

mm	millimetre
cm	centimetre
m	metre
km	kilometre
ha	hectare
g	gramme
kg	kilogramme
t	metric tonne

Exchange rate

Unless otherwise stated the average official exchange rate used in this study (as at mid-1994) is:
1 US \$ = T.Shs. 520

1.0 INTRODUCTION

1.1 Role of agricultural landuse practices in ecological degradation in Tanzania

Tanzania has an area of 945000 km², a population of 25 million people growing at 2.8% per annum and a population density of 29 people per sq.km. It has a tropical climate, a diverse ecology with different physiographic zones and a complex topography (URT 1991, EIU 1992, NEAP 1994). About 80% of the population live in rural areas where the majority are agricultural smallholder farmers. The land-use patterns of the country consist of smallholder cultivation (5%), large scale agriculture (1%), grazing land (39%) woodlands and forest (50%) and other landuses (5%) (NCSSD 1994). The agricultural potential of the country is still high as reflected by a favourable man/arable land ratio, diverse agro-climates and substantial untapped resources. As an example, out of the 88.6 million hectares that make up mainland Tanzania, about 39.5 million hectares are cultivable under rain-fed conditions but presently only about 6 million hectares (about 16% of the total potential cultivable land) are cultivated (Prazmowski 1987, NCSSD 1994). This land is not evenly distributed such that land scarcity is a reality in several highly populated areas of the country and, the tendency is to find population concentration in high economic potential areas. However, despite the immense agricultural potential in the country, poverty is still an insurmountable problem and environmental degradation have worsened over time (Jerve 1990).

With the majority of the people being the rural poor engaged mainly in smallholder farming, addressing poverty in Tanzania is synonymous with rural development. This is a question of developing agriculture which by being the mainstay of the economy and the major landuse in the country is therefore the major source of ecological degradation (TFAP 1989, Jerve 1990, Mascarenhas 1991, NEAP 1994, NCSSD 1994). In Tanzania, agriculture accounts for 50% of the Gross Domestic Product (GDP), 75% of export earnings and 80% of the total employment. Moreover peasant agriculture contributes 75% of national agricultural earnings, 90% of the marketed cereals and occupies about 85% of the area under crop production (NEAP 1994). Most of the changes in agriculture, whether planned or spontaneous, whether intensifying the use of land or expanding agricultural land, enhance the process of ecological degradation (Jerve 1990). Consequently, without underrating other landuses, any attempt to address ecological problems in Tanzania must dwell to a great extent on landuse practices mainly related to agriculture (LRDC 1987, Mnzava & Riihinen 1989, TFAP 1989, Mascarenhas 1991, NEAP 1994).

In recent years, the pressure on natural resources in Tanzania has progressively escalated and ecological degradation is very evident (Mascarenhas 1991). This situation manifests itself through effects such as the apparent high deforestation rate, decline in crop harvests, changes in the hydrological balance, erratic rainfall, soil erosion and many others (Chillumba 1984, Rwechungura 1985, TFAP 1989, Mnzava & Riihinen 1989). Forest and woodland degradation is a consequence of excessive exploitation and persistent inappropriate landuse systems such as shifting cultivation, slash and burn technique of farm clearing, forest encroachment for agricultural expansion, uncontrolled and frequent bushfires, nonuse of soil conservation measures, shorter fallowing periods and clearing of marginal lands for agriculture among others

(TFAP 1989, Kowero 1990, Mascarenhas 1991).

Several constraints are responsible for excessive exploitation of forest resources and distortion of the formerly sustainable local landuse systems. The major ones include rapid population growth, poverty among the peasants, impact of the modern sector which has brought commercialization of agriculture on the basis of declining terms of trade for agricultural crops but high prices for inputs, inconsistent and incomprehensive Government policies and legislation, unreliable climate, lack of responsibility due to undefined land rights and rural to urban migration (LRDC 1987, Gibbon, Havnevik & Hermele 1993, Ahlback 1992, Kaoneka 1993). Such factors have enhanced the vicious cycle of poverty which peasants have failed to opt out easily because land is continuously being put at the service of forces beyond their control (WCED 1987, Somogyi 1989, FAO 1991, Kaoneka 1993). Landuse planning at the household farm level is among the viable policies to alleviate some of these constraints to foster sustainable landuse management and prevent ecological degradation (Jerve 1990, Van Lier 1988).

1.2 Ecological degradation in Tanzania's catchment forests and the need to protect the tropical rainforest in the Nguru mountains

Tanzania is endowed with relatively large quantities of forest resources but they are disappearing fast due to the high rate of deforestation estimated at 0.3 % per annum or 130000 ha per annum (Sharma 1992). Nearly half (about 44 million hectares or 45%) of Tanzania's land area is classified as forested and about 25% of this is legally protected as Forest Reserves (Ahlback 1986, 1988 & 1992, TFAP 1989). Of the reserved forest land about 1.6 million hectares are tropical rainforests mostly reserved as catchment forests to store and regulate the flow of fresh water streams and rivers as well as to protect soil and vegetation (Ahlback 1988). These are particularly confined to mountain areas especially the "Eastern Arc" mountains of Tanzania which receive sufficient and reliable rainfall (Bjørndalen 1992). In addition to the catchment role, these forests also produce timber and other forest products (Poc's 1990). In Tanzania, rainforests are situated in high agricultural potential areas, characterized by growing population density with most people heavily dependent on the adjacent protected forests where they cause disturbances through forest exploitation and a wide range of inappropriate land use practices (TFAP 1989).

The types and extent of human impacts in and around the Tanzania Catchment Forests has received wide coverage by several authors such as Hermansen *et al.* (1985), Lundgren (1985), Rodgers & Hall (1986), Poc's (1988), Kalaghe *et al.* (1988), Hamilton & Bensted-Smith (1989), Hamilton & Mwashia (1989), Kaoneka (1990), Nsolomo & Chamshama (1990), Norris (1990) and Bjørndalen (1991 & 1992) among others. They contend that there is high ecological degradation which is caused by excessive exploitation of forest resources for various reasons and poor land use practices in and around Forest Reserves. Although these studies recognize the need to address this problem in order to protect the forests and the environment, most simply end up only suggesting some general ways to alleviate the situation and lack critical analysis based on quantitative techniques. The Tanzania Forestry Action Plan (TFAP) (1989) also gives due recognition to the critical situation affecting natural forests particularly catchment forests. Since it underscores the integral role of forest conservation in rural development, it calls for creation

of an integrated framework for concerted action to preserve natural forests and the environment.

The Nguru mountains in Eastern Tanzania where the case study village, Mhonda (6° 08' S and 37° 35' E), is located are among the few remaining areas in Tanzania where the relatively intact tropical rainforest with all the natural vegetation belts still exist (Poc's *et al.* 1990). Such vegetation belts range from the lowland rainforest ("miombo" woodlands) on the alluvial plains to the alti-montane bamboo thickets on the high summits (Hermansen *et al.* 1985, Norris 1990). The Nguru mountains are still relatively unexplored mainly due to inaccessibility of the central parts. However, the presence of rich and unique flora and fauna in the rain forest in these mountains is recognized (Willan 1965, Lovett & Thomas 1988, Poc's 1982, Norris 1990, Bjørndalen 1992). This outstanding biotic diversity is of high value to the scientific community and has great potential for development utilization in the future. At present numerous indigenous species are utilized for various purposes (Poc's *et al.* 1990, Norris 1990). The rainforest is a principal water source for people living in the area. It is also a source of many forest products and intangible benefits that sustain the lives of the communities in the area particularly sustenance of agriculture. Due to this importance the Government has declared this pristine forest ecosystem as a Catchment Forest Reserve. However, due to depletion of forest resources in public lands, pressure has mounted on the Forest Reserve to the extent that it is threatened and the need to preserve this area has increased.

The inhabitants of the Nguru mountains particularly in Mhonda village are mainly peasant farmers engaged in subsistence farming practices and deriving some of their basic needs from the tropical rainforest in the neighborhood. These peasants recognize the importance of the tropical rainforest in their vicinity for sustenance of their life. This is reflected in the traditional value attached to forests (Mitzlaff 1991). This awareness is also a result of the government extension efforts and its policy to protect forests. However, despite this awareness, the peasants are actively involved in destroying the tropical rainforest and other woodlands through their excessive exploitation to meet local needs and through inappropriate landuse practices in and around the rainforest. Frequent incursions in the forest reserve give one evidence that forest reserve restrictions are often ignored especially when it comes to fulfillment of the vital local needs. The disturbances taking place in and around the rainforest as a result of these activities have negative impact on the rainforest's catchment value and biodiversity; and also causes decline of land productivity. Some recent preliminary studies carried out by Chamshama *et al.* (1990), Norris (1990), Nsolomo & Chamshama (1990) and Bjørndalen (1992) for catchment forests in Morogoro region reveal the existence of this alarming situation.

1.3 Objectives and main hypothesis of the study

In this study landuse planning at micro-level is seen as one interesting way to bring about sustainable resource management in the Nguru mountains. The study addresses landuse problems in the Nguru mountains in the context of landuse planning at the farm level as a means to achieve optimal allocation of farm resources and prevent deforestation. The broad objective of this study is to analyze farming systems in relation to sustainable management of the tropical rainforest in the Nguru mountains. The main idea is to investigate how changes in agricultural

practices can influence deforestation. The study aims at addressing peasant's basic landuse problems by hypothesizing that optimizing returns from land, labour and capital will improve people's income and their standard of living and in consequence reduce deforestation pressure on the tropical rainforest.

The more specific objectives are:

- (a) to carry out a comprehensive survey of resource availability, utilization and productivity in Mhonda village.
- (b) to investigate the effect of changes in resource uses on deforestation.
- (c) to use deterministic and stochastic linear and non-linear programming models for:
 - (i) optimal returns and allocation of land under the existing landuse practices by maximizing total net income while meeting subsistence needs of the household.
 - (ii) analyzing the effects of minimization of risk and labour use variations on landuse pattern, total net income, subsistence consumption and deforestation.
 - (iii) conducting sensitivity analysis on the impact of changes in population growth, land area, crop price and total working capital on total net income, household consumption and deforestation.
 - (iv) analyzing the possibilities for developing efficient landuse plans at household level in order to satisfy household needs and prevent ecological degradation and deforestation.
- (v) evaluating various policy measures and recommendations for implementation of efficient landuse plans.

1.4 Study outline and main limitations

1.4.1 Study outline

The organization of this report is tailored to the research objectives of the study. All the three main research objectives have been pursued exhaustively. However, considerable effort was also devoted to relevant literature as a necessary background for the empirical part of the study. The study first concentrates on analyzing agriculture because of its important role on deforestation pressure. Improving the existing agricultural practices at the micro-level is seen as a point of departure in efforts to reduce deforestation pressure. The study then focuses on analysis of deforestation as a consequence of agriculture production, risk and population growth. This is accomplished by probing deeply, using a mathematical programming model, into the interrelationships between deforestation, agriculture and other factors. The aim is to explain how these various factors affect deforestation of the tropical rainforest. The issue of deforestation is particularly important in this study and hence is treated in depth through an intensive case study approach, in order to understand complicated relationships which shape peasant farmer's behavior leading to deforestation.

Chapter 2 presents a review of literature on rural development, theories and doctrines on efficiency and transformation of peasant agriculture and strategies developed to transform peasant agriculture. The chapter also reviews theories of peasant household economics based on welfare theory focusing on the theory of the optimizing peasant and multiple objectives of peasant agriculture. It also gives a theoretical basis for peasant economic behaviour in relation to

agricultural resource use and deforestation. A conceptual framework guiding the present study is presented in the context of peasant decision making and farm planning models. Peasant agriculture is viewed as an integrated complex system operating under certain economic principles which govern the decision making process and hence models used for that purpose. The chapter also reviews the theoretical framework for mathematical programming in modeling peasant agriculture. It also focuses on previous empirical studies which applied welfare economic theory and mathematical programming to analyze peasant agriculture. Moreover, relevant studies of general character are also reviewed. A considerable effort was devoted for literature review presented in this chapter.

Chapter 3 presents an overview of the study area, the methods used for data collection and the types of data collected. It also presents the methods for data processing and analysis using micro-economic analysis and compromise programming. Two main aspects of research methodology were used: A socio-economic survey and mathematical programming (modeling). The procedure and main assumptions in developing the model are also presented. The chapter therefore, reviews formulation and operationalization of research questions and design of questionnaires and interviews, sampling procedure, data collection, data processing and analysis. This presentation may allow judging the relevance and quality of the data and may serve as a reference for similar empirical studies in the future.

Chapter 4 presents the main findings of the study and discussions of the results. First, an overview is given for the survey findings and discussions on resource availability, utilization and productivity. These resources are land, labour, capital and management factor. Main focus is on resource supply levels, utilization levels and output and incomes from these resources. An overview is also given on the factors influencing productivity and technological limitations under conditions of growing population and other constraints to production. The results of the socio-economic survey form an important background for the model developed in this study. Secondly, the chapter focuses on model analysis results and discussions. The optimal farm plans generated for various model situations under consideration are presented. These include sensitivity analyses in which the model was used to analyze the impact of various factors on farmers behaviour and deforestation pressure. More emphasis was put on the impact of various factors on deforestation pressure because that is the main focus of the study. The various factors tested included population growth, producer price changes, changes in fertilizer prices, risks to farming, working capital supply, labour and land availability. The validity of the formulated farm plans is tested by comparing these plans with the existing or actual farm plan for an average household in Mhonda village. The normative solutions obtained from the study results are presented to serve as benchmark targets for economic and forest-related policies.

Chapter 5 presents the general conclusions from the study results. It also presents policy recommendations that need to be implemented in the short-run, intermediate and long-term perspective to improve farmers income and agricultural practices to reduce deforestation pressure especially that resulting from population growth, risk and other agricultural related factors. The chapter focuses on the opportunities available to achieve these aims. Finally, several appendices are presented to elaborate some major aspects covered in the study.

1.4.2 Limitations of the study

This study has the following limitations which need to be taken into account when interpreting the results:

- (i) Some information presented in this study is based on farmer's willingness and ability to respond to questions. Thus reliability and accuracy of answers given cannot be guaranteed in all cases. Possibility of error in farmer's recollection of the past always exists. However, it is the author's belief that the reliability of most of the data is high and that people involved in the study did their best to give or record exact information.
- (ii) Subjective judgement and bias on the part of enumerators cannot be ruled out completely despite initial training on how to conduct the survey.
- (iii) Due to time limitation only cross-section data was collected. It was not possible to collect longitudinal or time series data in one year.
- (iv) Data collected is limited to only one village chosen as a case study in order to collect more detailed information and for practical reasons. Also due to limitations in time and funds.
- (v) Data paucity for some variables made it imperative to use proxy values or educated guesses whose accuracy cannot always be guaranteed.
- (vi) The assumptions made in the study may sometimes be unrealistic besides the limitations of mathematical programming.
- (v) The model developed in this study is a first generation model, hence may still need updating to modify it, to extend it or to test its predictive power under various conditions.
- (vi) The micro-economic analysis and the basic model are restricted to a static analysis. The dynamic aspects of the problem are considered in the subsequent analyses by incorporation of population growth and new land clearing as dynamic factors.
- (vii) General equilibrium effects such as the fact that preservation of the rainforest could affect prices, at least in the local economy - with corresponding repercussions - are not considered.

2.0 LITERATURE REVIEW

2.1 Some theoretical aspects on rural development, peasant agriculture, peasant household economics and mathematical programming

2.1.1 Nature of the problem of poverty in rural areas

One of the urgent questions in rural development is how to raise productivity among the rural poor especially in developing countries (McNamara 1975). One dimension of this problem is that benefits of economic growth have been inequitably distributed between urban and rural communities and between the rich and poor countries. The basic premise of this dimension is that the causes of poverty is due to skewed economic relationship which according to the "Dependency Theory" generates a process of underdevelopment. The second dimension is that the rural poor themselves have been unable to fully contribute to economic growth due to the vicious circle of poverty in which they are entangled (*ibid.*). The scale of the problem is illustrated by the growing number of absolute poor people and their enforced degradation which deepens with every passing year despite the world economic growth (World Bank 1992).

In sub-saharan Africa between 85 and 95 percent of people live in rural areas. Most of these people survive on a meagre annual per capita income of less than \$100 based largely on low productivity subsistence agriculture and livestock keeping (Lele 1975). Population growth rate is also high with annual rates in the range of 2.5 to 3.5 percent (Sharma 1992). Thus population pressure on land has been rising rapidly with all the consequent effects of poverty such as hunger, unstable family life, poor nutrition, ill health and little or no access to formal education and ecological degradation among others (World Bank 1992). Furthermore, there is a high rate of rural to urban migration. For example between 1957 and 1967 the migrant population in Dar es Salaam, Tanzania increased at an annual average rate of 8 percent. Also the population of the same city was 870 000 in 1978; 1.1 million in 1985; and 1.4 million in 1988 (Omari 1976, URT 1988, EIU 1994). However, urban employment has not been increasing rapidly enough to absorb the flood of rural immigrants partly due to particular enclave nature of industrial development (Somogyi 1989).

Therefore improving living standard and general welfare of the subsistence rural sector seems the only logical way of stimulating overall development and also as a holding operation to allow industrialization to advance sufficiently to absorb the rural exodus (Lele 1975). This seems so because in developing countries rural development has special importance since it is where the majority of the people live. In Tanzania, for instance, nearly 87 percent of the population lives in rural areas to the extent that addressing poverty is synonymous with rural development (Omari, 1976).

Focusing on this background, rural development has therefore received a great deal of attention in recent years in development literature, national plans, political platforms and in the lending programs of most donors (Heyer, Roberts & Williams, 1981). Also different approaches to analyze rural development have been advanced (*ibid.*). In general, rural development emerged as

a discipline after efforts at economic growth based on the experience of the developed north had produced undesirable results. A consensus was reached by the international community to deal with the problem of rural poverty. This study is another effort in that direction aimed at addressing some aspects of rural development problems in Tanzania.

2.1.2 The concept of rural development

Rural development is an all embracing approach which takes a number of forms many of which are combined with one another (Williams 1981). These include: development of natural resources, agricultural production, credit programs, irrigation schemes, farm settlements, extension services, marketing cooperatives, the production of chemical fertilizer, herbicides and pesticides, and high-yielding variety of seeds, and provision of physical and social infrastructure (*ibid*). The purpose of all this is to increase agricultural productivity and to improve the living standards of the rural people. From this perspective, Heyer, Roberts & Williams (1981) define rural development as "a planned change by public agencies based outside the rural areas". Lele (1975) also defines rural development "as improving living standards of the mass of the low-income population residing in rural areas and making the process of their development "self-sustaining".

To achieve the aims of rural development, specific issues have to be analyzed. Lele (*ibid*) classifies them as follows:

- (a) National policies: These include land tenure systems, commodity pricing and market systems, wages and interest rate structures, and so forth.
- (b) Administrative systems: these relate to the degree of centralization-decentralization in the governmental structure
- (c) Scope of institutional pluralism. This refers to the distribution of development responsibility among the normal Government structure, semi-autonomous Government structure, private, commercial and traditional institutions, and elective bodies.

2.1.3 Strategies for rural development

Most agencies of development have maintained the notion that development is impossible without their intervention and hence have often ignored the remarkable expansion in crop production for export and domestic markets by peasant farmers acting on their own initiative (Heyer, Roberts & Williams 1981). A quotation from the major World Bank policy document can be used to illustrate the agencies consensus on the strategy for rural development as follows:

" Since rural development is intended to reduce poverty, it must be clearly designed to increase production and raise productivity..... It is concerned with the modernization and monetization of rural society, and with its transition from its traditional isolation to integration with the national economy" (World Bank 1975).

It seems there is an assumption that increasing productivity and production for the market will improve the welfare of the rural poor and simultaneously increase their contribution to the national economy. It is also assumed that rural poor's contribution has been restricted by rural poor's traditional isolation which has on the other hand resulted into poverty. Thus poverty is

ascribed to traditionalization and not as the consequence of the skewed relationships of the peasantry to the national and international economy as hypothesized by the "Dependency Theory" of underdevelopment. This view denies peasants their history and ignores their contribution, past and present, to financing industrial investment and state institutions. It also reduces them to destitute who can do little for and by themselves (Heyer, Roberts & Williams 1981).

Historical record show, at least in Africa, that rural development has failed to achieve its aims with only few exceptions despite the intervention from outside (Omari 1976). This failure is caused by incompatibility of goals and means to achieve them. Also this is caused by rhetoric which asserts the mutual interest between rural population, rural development agencies and governments while concealing the reasons for failure (Heyer, Roberts & Williams 1981). Often the interests of the rural poor are heterogeneous and at variance with those of national and international agencies. Nevertheless external development agencies consistently present their agenda as embracing interests of all groups concerned. This assertion that rural development serves all, or almost all interests, is a necessary myth because the open recognition of conflict would threaten the whole strategy of rural development as currently pursued. It would also threaten the practitioners working for governments and international agencies, many of whom are sincere in their own concerns for the poor (Gibbon, Havnevik & Hermele 1993).

The need to present rural development as serving the interests of all concerned has led to the adoption of the language "peoples' participation" or "partnership" and strategies to secure the cooperation of the rural population for whom development projects are devised. This language of "participation", is at best, patronizing for the people who otherwise are seen as an obstacle of their own development, or unable to grasp the benefits of development until exposed to persuasion that it is indeed in their interests (Coulson 1981). Schultz (1964) denies the view of peasants as conservative and inert. He pictures peasants as rational and responsive to economic incentives and in consequence he developed the theory of modernization through induced innovation.

In rural development literature, where the terms "partnership and participation" are used it is clear that the rural population are the most subordinate of partners. Hence, the idea that rural development might be initiated by the rural population itself does not enter the conception of "rural development". Heyer Roberts & Williams (1981) note that "indeed, where the rural population takes an initiative on its own accord, its activities are distrusted by external agencies to such a degree that they are suppressed, diverted or pre-empted". The Ruvuma Development Association in Tanzania, a strikingly successful initiative from the rural population and one of the original models for what later became the official policy of "Ujamaa", came to be regarded as a threat to government and was eventually banned (Coulson 1981). This dilemma is recognized in the World Bank: " The manner in which early participation is to be achieved and balanced with the need for overall guidance and control from the centre, is a problem which can only be resolved within each country" (World Bank 1975).

Thus participation seems to mean getting people to do what outsiders think is good for them. "Overall guidance and control from the centre" defines the relationship between agencies of rural

development and peasants. It excludes peasants' conception of their own development. Heyer Roberts & Williams (1981) observe that when agencies interfere too much with the lives or goals of the peasants, the peasants may seek to circumvent them, hence compelling governments to impose even further control on peasants. Schultz's theories of modernization "paradigm" of development in the Third World partly supports this view. He notes that the recipe for agricultural and rural development is to invest in agricultural research and extension to develop and transfer modern technologies and knowledge to the peasant population. Agriculture is seen as an important source of surplus which could be invested to create growth and industrialization in underdeveloped countries. It seems plausible to conclude that while the goals of rural development are really worth pursuing, the problem is still how to achieve them. One of the recent approaches towards rural development implies growth and equity as the major objectives. In this sense governments and aid agencies would provide basic requirements to help people to build their own capacity for efficiency and self-reliance.

2.1.4 Why peasant farmers may oppose rural development programmes

The majority of the rural producers in developing countries including tropical Africa are still peasants who control the means of production and use family labour, increasingly supplemented by wage labour to produce domestic consumption needs both directly and by exchanging the products of their own labour on the market (Low 1986). These peasant production activities supply food and raw materials relatively cheap to the national economy and also serve as a source of revenue used to develop the rest of the economy (Lele 1975). However, peasants are also a problem because their ownership of the means of production and of subsistence gives them some degree of independence. Hence, they may be in a position to refuse to supply particular markets, or to agree to supply only on terms that are relatively favourable to them. Also when they hire in labour they directly compete with capitalist production which also depends for the source of labour on the existence of a class of wage labourers separated from the means of production. Such source of labour in Africa is the peasantry (Coulson 1981).

Although peasants may well agree that one of the major means of achieving rural development is to increase production for the market and improve productivity, they often resent this process being grafted on subsistence production at the expense of domestic consumption and cash income (*ibid.*). The tendency has been to try to increase peasant cash income by encouraging commercial crops while neglecting staple crops. This is an improvement if the volume and quality of domestic consumption does not suffer. It will do so unless enough land is available which can be deployed without any loss to subsistence production. Also labour must be available. Unfortunately both are often scarce (Ellis 1987). Peasants using their competence in their physical and social environment, may experiment with, and exchange information about new techniques and then reject them. New techniques may be rejected because they fail to increase yields, or only increase yields at the cost of increased labour and inputs which peasants cannot provide or buy or because equipment fall apart. New techniques may also be accepted but used for purposes not intended (Roberts 1981). Thus the common belief by external agencies that innovations offered to peasants are intrinsically viable simply because of their non-peasant origin and attachment of the stamp of approval to them contributes to the common description of rejection

as irrational "resistance to change"(Heyer, Roberts & Williams 1981). Furthermore, the dismal record of cooperatives, extension service and public provision of credit in African rural development programs also contribute to the seeming peasant resistance (Lele 1975).

2.1.5 Rural development policy in Tanzania

Rural development in Tanzania is the core of overall national social development policy and is actually a "post-Arusha declaration" phenomenon (Omari 1976). Earlier approaches (defined in section 2.1.8.5) have been "Transformation approach" and "Settlement schemes" both of which failed due to heavy reliance on money and foreign aid (Omari 1976, Coulson 1981, Tibaijuka 1984). Thus in 1967, Tanzania announced the country's new development doctrine of "Socialism and self-reliance as expressed in the "Arusha Declaration". A new strategy for rural development was one key component of the socialist programme. Another was economic policies (EIU 1994).

The declaration called for socialist integrated rural development strategy having the village community as the focus and purpose of all development endeavors. To effect this policy, in the late 1960s the government began to promote the grouping of scattered small villages and homesteads into what were termed "Ujamaa " villages ("Ujamaa" is a Kiswahili name for socialism or communal) each comprising of not less than 250 families intended as examples of how "African socialism" could develop without passing through the pains of capitalism (Omari 1976, Mlambiti 1985, EIU 1994). Slow progress in voluntarily moving to "Ujamaa" villages led the government to initiate compulsory villagization in the early 1970s through an "operation" branded "Operation Vijiji". This resulted in the resettlement of the rural population within a very short period of time, and the inadequate planning of the villages caused severe disruption to the rural economy. This process was completed in 1976 and by 1979 there were 8579 settlements of which 8210 were villages and 369 were service centres (Daily News Newspaper 17.5.79). It was envisioned that by establishing "Ujamaa" villages, rural Tanzania would develop much faster than if people remained in their scattered homesteads (Omari 1976). Such villages were to develop communal farming and eventually this would displace private farming as the primary village activity. The principles and goals of the "Ujamaa" policy were cherished by some people but its poor implementation was the main source of its resentment (Omari 1976). Also there were a number of socio-economic, cultural and political constraints (Mlambiti 1985).

Tanzania is predominantly rural and therefore agricultural transformation is a necessity than a choice. This was envisaged to be achieved through "Ujamaa" villages. The rationale for creating "Ujamaa" villages on the principle of self-reliance is that in the past, Tanzania has relied too much on big plantations which created differentiation in rural areas, thus leading to class development and exploitation (Omari 1976). After the "Arusha Declaration" large foreign-owned estates in sisal, tea, and coffee were nationalized. Also the states role in the economy was extended through nationalization of banking, insurance and large private trading companies. The industrial sector became dominated by mixed companies with Government holding majority of shares or total ownership (Coulson 1981).

However, by 1980s the economy performed poorly due to many causes both internal and external

(Somogyi 1989, Gibbon, Havnevik & Hermele 1993). This economic decline compelled the country in 1986 to reach an agreement with the International Monetary Fund (IMF) resulting into adoption of the Structural Adjustment Policies which led to major economic reforms culminating into a more free market-oriented economy. The amendment in 1991 of the Leadership Code, amid great controversy, to permit members of the ruling party (CCM) to engage in private business was seen by many as the end of the socialist era (EIU 1994). The 1993/1994 government budget introduced the first three-year Rolling Plan and Forward Budget (RPF) in place of the former fixed-term programmes, all this reflecting a U-turn in the development strategy (*ibid.*). Since today the bulk of agricultural production continues to be private subsistence farming by peasant families, these changes will certainly have some impact on land use policies as well rural development strategy.

2.1.6 Land use planning as a tool for sustainable resource management in Tanzania

Since her independence in 1961, Tanzania realized the importance of land to her development and attached great importance on land husbandry. It was realized that land needed to be managed properly in order to optimize agricultural production (Prazmowski 1987). However, in view of the apparent deteriorating ecological conditions, it is evident that land has been abused in many parts of the country. Lack of land use planning to rationalize the use of land is among the main factors that have led to this situation (Rwechungura 1985, LRDC 1987). In spite of the country's growing human and livestock population, land use planning and conservation services have been very poorly organized (Rudengrén 1981). These services have stagnated to the extent that land degradation has reached high proportions (Rwechungura 1985). There have been very little emphasis on integrated land use planning despite the realization that multi-sectoral cooperation at all levels is necessary to reconcile the conflicting land uses (Mascarenhas 1991). Whenever there have been attempts for land use planning the common practice was to put more emphasis on personal intuition, guesswork and qualitative analysis especially at lower levels (Helmsing 1989). At higher levels the approaches have been superficial, fundamentally sectoral and uncoordinated for implementation and have failed to achieve sustainable land use management to address ecological degradation (LRDC 1987). Only recently the need to expand the scope of land use planning has been voiced in order to foster multi-sectoral cooperation and coordination in addressing land use problems more comprehensively at all levels. The continuous rapid growth in population (2.8% per annum and projected to continue at that high rate over the next few decades) coupled with the ever increasing local and commercial exploitation of land resources should and have eventually made land use planning and its application to land management one of the top priorities of national concern in recent times (Mascarenhas 1991, Kaoneka 1993). Competition of land use between forestry, agriculture and other disciplines as well as ecological degradation are some of the important aspects of this problem (TFAP 1989, Mascarenhas 1991).

Soon after gaining her independence, Tanzania adopted a central planning policy (Mgeni & Price 1993) but later switched to decentralized planning policy following the realization that the country's rural development strategy is essentially propelled by micro-level decisions (*ibid.*). Under such planning policy, application of quantitative micro-level planning is imperative to design optimal land use plans at the micro level in order to reverse land and ecological

degradation, raise household food production and increase household cash earnings to improve standard of living. However, the application of quantitative techniques in landuse planning has remained elusive. Among the few studies on landuse planning that have been documented in Tanzania in recent years are such as those by Chillumba (1984), Rwechungura (1985) and Mwalyosi (1990). These were focused on qualitative assessment of the various landuse practices and problems in the country and how these problems hamper agricultural development and natural resource use at various levels. Some of the few studies that used quantitative modelling techniques applications in farm/landuse planning in Tanzania are those by Dykstra (1980), Tibaijuka (1984) Mgeni (1986) and Kaoneka (1993) as discussed in appropriate sections of this report. There is need to expand the scope of farm/landuse planning using modeling techniques in Tanzania in order to address landuse and resource problems more comprehensively.

2.1.7 Landuse planning at farm enterprise level

Due to the strong link between agricultural practices and tropical rain forest degradation, land use planning at farm enterprise level is a useful strategy to elicit peasant farmer's adoption of appropriate landuse practices and in consequence reduce ecological degradation. At the farm enterprise level there is seasonality of labour, and people are confronted with risks in production due to uncertainties in the weather and market conditions. Landuse planning at farm enterprise level addresses these and some important problems of agricultural economics such as land allocation and distribution, cropping pattern design, labour allocation and risk management among others (Despotis & Siskos 1992; Siskos, Sharifi & Van Keulen 1994).

These problems are often addressed in an endeavour aimed at satisfying a number of socio-economic objectives in an environment of scarce resources (Siskos, Despotis & Ghediri 1994). These competitive multiple objectives in landuse planning include profitability of enterprises, creation of stable employment, seasonality of labour, minimum risk, environmental balance and water resources saving. Examining these objectives one can identify conflict among them. Risk aversion implies that one has to avoid risk. The need to have efficient use of labour requires keeping excess labour requirement at a minimum during busy times and to have enough work to keep all labour occupied during slack periods. The desire for a high level of income is reflected by the maximization of gross margin which is the contribution to the fixed cost and profit. Failure to address problems associated with these objectives is viewed in this study as one main reason for the peasant's ambivalent behaviour towards unsustainable management and utilization of natural resources in their vicinity.

Land use planning at the farm level is undertaken to design optimal or efficient patterns of use of scarce resources. These different patterns of use of scarce resources can change not only production mix and levels of use of various resources but also the distribution of crops and other production activities. According to Sharifi & van Keulen (1994) agricultural systems in the rural sector are dynamic and require the efficient use of resources. Thus the peasant farm operator is frequently faced with decision problems with respect to landuse. These problems often translate into conflict between agriculture and other competing landuses such as forestry. In an environment of multiple and often conflicting demands on the development and use of resources,

and including complex processes, the farmer can be aided, in choice of development plan, by a tool that can analyze information in such a way that the consequences of various strategies or options can be evaluated. Multi-objective mathematical programming and related techniques provide an operational methodology for handling multiple objectives within the framework of traditional mathematical programming.

2.1.8 Peasant agriculture

2.1.8.1 Its Rationality and relevance

Agricultural systems based on experience and social institutions accumulated over many generations are referred to as "traditional" or "peasant" agriculture (Schultz 1964, Tibaijuka 1984, Ellis 1987). A more operational description of these agricultural systems is quoted from Nakajima (1965). Based on the continuum of two dimensions, he observes that: "...the proportion of production consumed in one dimension and that of family labour in another - such that at one extreme can be conceived a farm of pure subsistence production using only family labour and at the other a pure commercial farm using only hired labour" (figure 2.1). He also observes that "the former is rarely found in the real world and the latter is likely to be very small in percentage". Peasant societies lie in the neighborhood of the first quadrant. However, with time farms move away from the first quadrant towards the direction of the third quadrant according to Krishna (1965): "dual agriculture or agriculture whose output partly goes home and partly goes out is transitional agriculture and it cannot be overemphasized that transition is a one-way affair: the home - consumption ratio keeps falling and the sale ratio rising - not necessarily to zero but to some critical limit". The forces causing this unidirectional movements are the development of transport and communications, the monetization of economic relations and technological change all embraced by the market forces. Krishna further notes that " there is a stagnation in areas which remain mainly unaffected by any of these forces".

The rationality of peasant agriculture lies in its efficient use of resources and factors of production and rational response to price changes and other economic incentives (Tax 1953, Jones 1960). The doctrine that peasant agriculture is inefficient and has a marginal productivity of zero value therefore available for other economic activities such as industrialization at no opportunity cost was also dispelled by Schultz (1964). His thesis was that peasant agriculture is efficient and therefore significant growth in productivity cannot be brought about by the reallocation of resources in peasant agricultural systems. He postulated that opportunities for growth would become available only through technological improvements such as adoption of new husbandry practices, use of improved seed varieties and fertilizer. Schultz's ideas were also refined by Hayami & Ruttan, (1971 & 1984) through their models of "induced technological innovation and "induced institutional innovation which formed much of the basis for the "transfer of technology" approach (Holden 1991). They also observed that: " a new consensus seem to have emerged that an effective economic development strategy particularly during the early stages of economic growth depends critically on the achievement of rapid technological change leading to productivity growth in agriculture".

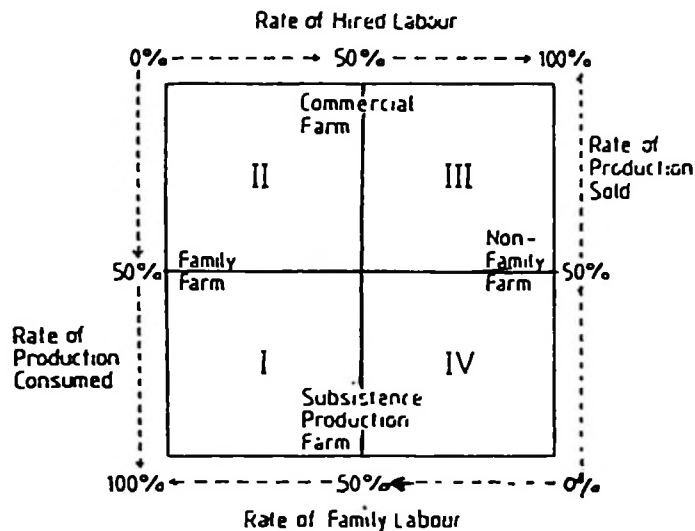

Figure 2.1 The classification of farms as presented by Nakajima (1965).

In consequence to this doctrine, rural development came to be placed in new investments and technologies such as in breeding programmes to develop high yielding varieties of major cereal crops for tropics, chemical fertilizers and pesticides. This led to what came to be known as the "Green Revolution" which was largely successful in creating increased production in Asia although it was criticized for not solving the hunger problems of the poorer parts of the population (Mellor 1966, Johnson 1968). The impact of the Green Revolution was much lower in Africa because the technologies associated with it were most suited for high potential areas with good infrastructure. They did not function so well under the marginal conditions which predominate in Africa (Holden 1991). To this effect, the domination of the pre-1960 literature on peasant economics, by examples of backward bending supply curve for wage labour or cash crops and the branding of peasants as lazy and conservative with a very high rate of leisure preference was a misconception of the peasant economics.

Nakajima (1965) and Mellor (1966) used a low achievement standard as a hypothesis to explain the seeming paradox in developing countries namely considerable idleness among peasants despite the low level of incomes and rather high marginal labour productivity. This seeming paradox was attributed to the problem of seasonality and a failure to distinguish between idleness in peak labour seasons and that in off seasons (Tang 1965). He also doubts the hypothesis that income aspirations of the typical peasant are low. He notes that "even in poor isolated villages there is a sufficient internal income variation and contact with the outside to keep income aspirations of a typical villager a safe distance ahead of his realized earnings".

Johnston and Kilby (1975) like Schultz (1964) maintain that with proper incentives accompanied by agricultural services peasant farmers would generally respond positively to producing surpluses for the market. In the absence of incentives or when governments have pursued policies which have threatened the objectives of the peasants, they have successfully withdrawn from the monetary sector back to pure subsistence. Hydén (1980) discusses the uncaptured peasantry in Tanzania meaning that the government of Tanzania failed to integrate the peasant farmer into the monetary economy. As public services slackened and the terms of trade moved against rural producers they withdrew back to subsistence and leisure. However, the market-oriented economic reforms introduced in Tanzania since 1986, resulted into stuffing shops with "incentive goods" stimulating the peasants back to the monetary economy (Gibbon, Havnevik & Hermele 1993). There is of course a limit to peasants' ability to withdraw from the market hence from national demands. Chayanov (1966) observed that peasants have to fulfill their basic needs and to do so they will continue producing for the market at profitability levels unacceptable to the capitalistic enterprise. Baumol (1977) observes that, in strict terms, no rational individual can be expected to produce for the market at a net monetary loss. In the economic sense it is always the opportunity cost price that matters to an individual. From microeconomic theory, value is determined by the marginal utility of a commodity at a particular point in time. Thus at a given time, a rational consumer maximizes total utility by paying for a commodity until its marginal utility equals its price. The relevance of peasant agriculture lies in two categories namely: its role in peasant subsistence and also its role in the national economy. The importance of peasant agriculture in peasant households is discussed at length in the sections which follow. Hence in this section emphasis will be on the role of peasant agriculture in the national economy.

The economies of most developing countries are agrarian based and hence at the core of rural development activities is the transformation of peasant agriculture (Lele 1975). In most cases this peasant agricultural sector is the main employer of the labour force and account for almost half of the Gross Domestic Product (GDP) and export earnings (Tibaijuka 1984). In Tanzania the place of agriculture which is dominated by the peasant sector is paramount. But it is important to note that the peasant sector contributes about 30-40 percent of the GDP annually and the total agricultural sector contributes about 62 percent of the GDP at an annual growth rate of 4.4 percent (EIU 1994). Various types of peasant agricultural systems have been developed in the tropics to suit specific ecological conditions (Ruthenberg 1975). This diversity of farming systems in the tropics, particularly in Africa, has two common features: the simplicity of the technologies used and the low level of productivity. The production is mainly subsistence with a declining trend and this have had severe consequences on development since agriculture is the backbone of the economies (Mlambiti 1985).

Therefore the development of agriculture, particularly the transformation of the peasant sector, is generally accepted as a precondition for overall economic growth since no successful industrialization can take off in developing countries without growth in agriculture (Lele 1975). Hayami & Ruttan (1985) note that there has been a shift away from an earlier "industrial fundamentalism" to an emphasis on the importance of growth in agricultural productivity and production to foster total development process. Chambers (1974) summarizes the whole question as follows: " the importance of self-sufficiency in food in order to save foreign exchange and to keep down urban wages; the need to develop cash crops in order to earn foreign exchange, particularly in those countries which lack minerals or oil for export; the existence of under-exploited land and labour which can relatively easily be brought into production; the desirability of increasing rural purchasing power to provide markets for the new urban products..... are among the most persuasive economic reasons for the shift of priority towards agricultural development, reasons which seem unlikely to lose much of their force during the next decade and perhaps for much longer".

However, despite this importance of agriculture in development, the means to speed up this process are still not understood and little is known about the factors and conditions under which the agricultural surplus can occur and be sustained. Schultz (1964) underscores this point when he observes that: "most people in the world are poor. If we knew the economics of being poor, we would know much of the economics that really matters. Most of the world's poor people earn their living from agriculture, if we knew the economics of agriculture, we would know much of the economics of being poor". Therefore there is inadequate knowledge on the process of agricultural development which underlies the whole economic growth in developing countries. The great concern on the issue have led to the development of peasant household economics which are discussed in detail together with concepts of rural development. The present study draws from these theories to design and approach peasant problems in the Nguru mountains in Tanzania.

2.1.8.2 Review of theories on efficiency and transformation of peasant agriculture

The validity of Schultz's peasant efficiency hypothesis has been tested by Masell & Johnson (1968) and Hill (1970) among others. Many of these estimated the Cobb-Douglas production function from which the average marginal value productivity was estimated. Through comparison they found that in most cases the average marginal value productivity (MVP) did not differ significantly from the marginal factor cost (MFC) leading to the conclusion that these production systems were efficient in conformity with Schultz's hypothesis. Shapiro (1974 & 1983) on the contrary, advanced ideas against the peasant efficiency hypothesis by concluding that immobile resources in developing countries may lead to allocative inefficiency and may leave scope for appreciable increases in output through reallocation. He further noted that the efficiency hypothesis may not be applicable to much of peasant agriculture. He gives the reason that decision makers may fruitfully increase effort such as extension and education aimed at improving the allocation and use of available resources so that more farmers come to operate closer to the efficiency ideals now achieved by only a few. Shapiro cites his case study in the cotton growing area of Geita in Tanzania as a typical example which showed that output could

be increased by 51 percent if all farmers achieved those levels of technical efficiency that were in fact achieved by the best farmers in the sample using the same inputs and technologies that the less efficient farmers used. The contradictions between Schultz and Shapiro call for greater theoretical review of peasant economics because of their direct implications on the strategy and policy of agricultural improvement. A middle ground in this argument seems safer because while it is impossible to prove Schultz's hypothesis Shapiro also fails to falsify it. Hence it is logical to incline on applicability than the proof of either of the two schools of thought. Tibaijuka (1984) observed that the contradictions on whether or not peasant farming is efficient are arbitrary and are caused by the free interchange of the words productivity and efficiency by earlier researchers on the subject. While these words mean differently they were treated as synonymous.

According to Ellis (1987), productivity refers to the changes in the marginal physical product (MPP) of a particular input such as labour or land along the production function. This normally follows the law of diminishing returns. Efficiency on the other hand is a more complicated term referring to technical, allocative and economic efficiencies, a subject further discussed in section 2.1.9.2. However, a process or technique that is technically inefficient given the available technology will never be used provided technological information freely flows among the producers (Lancaster 1970). Experience from the "Green Revolution" demonstrate that awareness of an improved technology does not automatically lead to its adoption by everyone in the society. One must also be able to meet the costs involved (such as putting a good infrastructure in place) and be willing to bear the associated necessary risks (Rajaraman 1977). This partly explains why some farmers in poorer parts of the population in Asia and Africa as a whole did not fully benefit from the Green Revolution technologies (Holden 1991). It also partly explains why some farmers do not move to higher efficiency levels (Tibaijuka 1984).

2.1.8.3 Theories and models on peasant agriculture transformation

One important question arising from embracing Schultz's theory is how peasant agriculture can be rapidly improved to raise productivity and output in order to transform the peasant agricultural based economy. Several theories have been advanced to tackle this question. Some will be reviewed here to foster understanding of the complex interactions of resources and other economic entities that lead to technological change and hence growth in agricultural productivity. Hayami & Ruttan (1971) grouped agricultural development theories into four models namely: (a) the conservation model (b) the urban-industrial impact model (c) the diffusion model (d) the high pay-off input model. In addition to these, Boserup's model: Population increase and technology, will also be reviewed because of its importance in relation to this study.

The conservation model

This model views agriculture as a relatively self-contained system in which the inputs are supposedly within the agricultural sector itself. Increased land productivity is achieved through a combination of techniques such as labour intensive methods of fertility enhancement, land development and capital formation in the form of livestock and perennial (fruit/nut bearing) trees. The limitation of the conservation model is that it can contribute to agricultural productivity

increases in the range of one percent per annum over relatively long periods (Hayami & Ruttan 1971). This is a too slow growth rate to conform with the higher rate needed by developing countries to catch up with the contemporary rapid population growth. This model also ignores the interaction of agriculture with other sectors of the economy. Hence the full impact of technical change on resource use and productivity is not taken into account (*ibid.*).

The urban-industrial impact model

This elucidates the geographical variations in the intensity of farming and in the productivity of agricultural labour in an industrializing economy. Drawing on the Ricardian theory of rent, Von Thunen (1783-1850) showed how urbanization determines the location production of agricultural commodities and influences the techniques and intensity of cultivation. Schultz's observation cited by Hayami & Ruttan (1971) gives a summary of this model as follows:

"(i) economic development occurs in a specific locational matrix.... (ii) these locational matrices are primarily industrial-urban in composition (iii) the existing economic organization works best at or near the centre of a particular matrix of economic development and it also works best in those parts of agriculture which are situated favourably in relation to such centre". The implication is that there is more efficient functioning of factor and products markets in areas of rapid urban industrial development than in areas where the urban economy has not made a transition to the industrial stage (*ibid.*). Subsequent empirical studies have maintained the validity of this hypothesis and urban-industrial growth seems to explain geographical differentials in per capita or per worker farm income (Hayami & Ruttan 1971).

Tibaijuka (1984) observed that this model is more relevant to the backward regions of the industrialized countries. In developing countries the model has a limited scope. The major problem in these countries is how to achieve a satisfactory rate of economic growth in the non-farm sector than the geographical distribution of economic activities. Furthermore, the technological prerequisite for rapid agricultural growth in the face of a constant or expanding agricultural labour force are not available. Moreover the growth of urban centres due to increasing population pressure in rural areas is far greater than demand for non-farm employment (Hayami & Ruttan 1971).

The Diffusion model

This is derived from the empirical observation of substantial differences in land and labour productivity among farmers in any agricultural region or village. Therefore the model recognizes the existence of efficiency differential among the farmers (Tibaijuka 1984). These efficiency differentials are mainly due to disparities in adoption of innovations by the farmers (Ellis 1987). The importance of the diffusion of farmer innovations to the rest of the community need not be over emphasized (Nou 1967). Thus through effective dissemination of technical knowledge from the most advanced to the backward farmer, agricultural productivity can increase. The main limitation of this model is the complicated nature of the diffusion process (Tibaijuka 1984). Innovation may not be transferred from one farmer to another because of many causes such as institutional impediments or because the backward farmer cannot afford to meet the costs or take

the risks involved (Rajaraman 1977). Mosher (1966) notes that some essential factors must be present for even one farmer to adopt an innovation. These factors include (i) markets for farm products (ii) local availability of input supplies where and when needed (iii) incentives like prices to offset risk and (iv) transportation or product distribution. Furthermore he outlines the factors necessary for an innovation to be adopted for the majority of farmers. These he called accelerators and they include: (i) education on specific innovations (ii) credit ((iii) national planning (iv) group action by farmers to enlighten extension work (v) improving and expanding agricultural land.

This requires setting up institutions for promoting technology research, extension of credit, marketing, input distribution, incentives, transportation, farmer's associations and land improvement. Indeed all aspects of rural development planning come into the equation of fostering adoption of innovations by farmers. Tibaijuka (1984) notes that the early agricultural extension efforts relied heavily on this model but found out that rapid modernization of peasant farming and rapid growth in agricultural output is difficult to achieve. Innovations themselves cannot be introduced in other areas without being re-adjusted to function in the new environment (Kulp 1970). This has led to a new perspective that agricultural technology is highly "locational specific" so that technology developed in advanced regions or countries cannot in most cases be directly transferred to less developed ones (Rajaraman 1977, Solberg 1988, Tibaijuka 1984).

The high pay-off input model

The limitations inherent in the diffusion model led Schultz to develop this model. The main thesis of this model is that the key to transforming peasant agriculture into a productive source of economic growth is investment in order to make high pay-off inputs available to farmers in poor countries or regions. The areas of investment are: (i) agricultural experimental stations to produce new knowledge (ii) industrial sector to develop, produce and market new technical inputs and (iii) extension to encourage farmers to use modern agricultural factors effectively.

The Indian "Green Revolution" where new rice and wheat varieties were developed is a case in point (Rajaraman 1977).

According to Tibaijuka (1984) the main shortcoming of this model is that it is incomplete due to the following reasons: (i) it does not tell how to raise the resources necessary to stimulate agricultural growth (ii) it does not explain how economic conditions induce the development and adoption of an efficient set of technologies by a country or a farmer (iii) It does not specify the process by which factor and product prices relationships induce investment in research in a particular direction (iv) It does not handle the complicated nature of the diffusion process.

The induced development model

Drawing on Hicks theory of wages and in response to the shortcomings of the above models, Hayami & Ruttan (1971) developed this model which incorporates the first four models and aspires to improve their weaknesses and rectify omissions. They note that this model embraces as critical elements for agricultural and economic development the mechanisms of:

- (a) induced innovation in the private and public sector
- (b) interaction between technical change and institutional development and
- (c) dynamic sequences of technical change and economic growth. They further observe that changes or differences in the relative prices of factors of production or products do influence the direction of invention and innovation both in the private and public sectors.

Thus either individual firms or the public sector can be motivated to develop new technologies to replace expensive factors. For example, machines are developed to replace labour which progressively becomes expensive with time and improved seeds and fertilizers are developed to replace land (Hayami & Ruttan 1971). They further note that as a consequence of technological innovations, changes are made "to enable both individuals and society to take fuller advantage of new technological opportunities" (*ibid.*). Thus land tenure systems might be changed from communal to individual tenure to internalize the gains of entrepreneurial innovation by individual farmers. The necessary institutional changes are not uniform however, and will of course depend on the prevailing situation.

In Africa, the traditional system of communal land tenure is viewed by some as a bottleneck to higher land productivity and modernization (Hunter & Mabbs-Zeno 1986). Also in most African countries land is seen to have no market value and this may limit incentives to invest in conservation measures (Holden 1991). Thus it is viewed that a change of the traditional African land tenure system is a prerequisite for agricultural development. This is based on the argument that lack of individual ownership of land causes insecurity and farmers refuse to make long term farm improvements and investment particularly in conservation and reforestation (Openshaw & Morris 1979). Furthermore, adjudication and registration of land enables peasants to obtain credit by pledging their land as collateral or security. This in turn makes the adoption of better husbandry practices and use of inputs possible (Bojö 1991). The general economic theory states that asset markets for land offer enough incentives for an owner with a short term personal time horizon to make plans consistent with a much longer term perspective (Randall 1987).

However, privatization of land tenure if done prematurely could lead to land speculation, absentee landlordship and increase landlessness and in consequence forcing weaker groups into exploitative tenancy arrangements. This can be counter productive (Low 1986, Beets 1990). Since smallholders have been shown to be more productive than large farmers, limiting concentration of land ownership would give positive results on agricultural production (Okoth-Ogendo 1976). The importance of field-based research on existing tenure institutions is very crucial to avoid pushing agricultural strategies in unexpected or undesired direction (Cohen 1980).

The specification of rights over land has been subject to considerable political controversy in both capitalist and socialist camps and a consensus can be drawn from past failures. Land reforms aiming at changing tenure systems have either tended to result in inefficient production or have created a large class of landless people (Holden 1991). This led Hunter & Mabbs-Zeno (1986) to the conclusion that "the considerable African experience with land reform displays fundamental divergence from these paradigms, resulting both from the unique institutional composition existing in Africa and from the present relationship of Africa to the rest of the world. Tenure systems have shown greater flexibility than is generally acknowledged, suggesting

that efforts to strengthen agricultural performance should not focus on these systems as a constraint to development". They thus suggested that it is better to build on existing institutions as most African governments and bureaucracies have no means to launch new systems. The focus should thus be on integration of traditional and scientific knowledge and on evolution rather than revolution with the traditional systems as starting points (Simmonds 1985). Chambers (1983) stated that "indigenous agricultural knowledge may be the single largest knowledge resource not yet mobilized in the development enterprise".

Hayami & Ruttan (1971) maintain that institutional changes are therefore necessary to enable society to make gains from advances in agricultural technology. They observe that "changes in market prices and technological opportunities introduce disequilibrium in existing institutional arrangements by creating profitable new opportunities for the institutional innovations. However they caution that profitable opportunities do not necessarily lead to immediate institutional innovations since there are typically vested interests which are bound to lose and hence oppose change". The process of transforming institutions in response to technical and economic opportunities generally involves time lags, social and political stress and in some cases disruption of social and political order. Economic growth ultimately depends on the flexibility and efficiency of society in transforming itself in response to technical and economic opportunities (*ibid.*). The whole process can be viewed as a dynamic sequence of technical change in which one problem causes disequilibrium and in response a solution is found.

This solution may also cause a new problem to which then a solution has to be sought. This process repeats both within agriculture itself and also between agriculture and other sectors. Such imbalances within agriculture and between agriculture and other sectors of the economy is an important source of backward and forward linkages in transmitting technical progress in agriculture to overall economic development. In conclusion, the induced development model is also incomplete since technical change in agriculture is not wholly of an induced character. Resource endowment, progress of general science and technology have important influences. Nonetheless, this model has managed to bring to light the main issues necessary for induced planned change in agriculture (Morris 1981, Tibaijuka 1984).

2.1.8.4 Boserup's model: population increase and technology

Boserup (1965) analyzed the problem of agricultural progress in peasant (which she referred to as "primitive") societies of Third World countries particularly India from an entirely new angle (Bryceson 1985). She regarded the growth of population as the autonomous factor making for a steady intensification in agriculture which in turn brings the whole host of economic and sociological changes in a "train". Her main thesis is that, contrary to the prevailing view, peasant communities with a sustained population growth have a better chance of getting into a process of genuine economic development than peasant communities with stagnant or declining populations. This thesis is subject to qualification: as she put it herself, "it may not be true of communities with a very high rate of population growth which are already densely peopled, and which are unable to undertake the investment necessary for introducing still more intensive methods of agricultural cultivation". She further pointed out that primitive agricultural communities are "dynamic", hence they are subject to continuing change in agricultural

technology induced by population pressure, even though these changes may not be as fast as those experienced in the agricultural sectors of the industrially advanced countries.

In a critical view, Boserup using evidence of existing Third World agricultural practices argues that the human response to land shortage is the adoption of more productive tools which serve to intensify land and labour usage. The succession from shifting cultivation with digging sticks to hoes, to more intensive agricultural techniques with shorter fallow periods and ploughs, progressing to permanent mixed agriculture all aim at intensifying land and labour usage to raise agricultural production. Boserup thesis suggest that population growth therefore actually serves to develop the agrarian economy technically and often materially rather than impoverish it as some earlier thinkers like Malthus argued (Bryceson 1985). The underlying assumption behind Boserup's theory is that increasing land productivity has historically been bought at the cost of labour intensification. However, agrarian non-market societies are unwilling to intensify their labour expenditure until population pressure and human survival needs make it imperative (*ibid.*).

In Boserup's analytical framework, population is the independent variable and is positively correlated with the dependent variable, namely, technological development in food production (Boserup 1965). Thus population growth may proceed even under food supply constrictions (*ibid.*). She is optimistic towards the beneficial effects of population densities, but her stress is on the effects of population increase on technology rather than the division of labour. Labour intensification requires a restructuring of the division of labour and Boserup clearly illustrates this with respect to women's participation in agricultural production under different agricultural regimes. Boserup (1965) also traces the effect of population growth on the development of technology and material culture. Food supply was a constraint on the growth of urban settlements and its concomitant, the elaboration of the division of labour. Bryceson (1985) observes that "ancient and medieval cities arose not so much in areas known for higher than average agricultural productivity, but rather in places where there was a particularly high density of rural population in close proximity. It is the absolute rather than the relative surplus of grain that accrued subsistence agricultural systems that was critical to urban development in ancient medieval times".

Boserup goes on to caution, however, that the positive relationship between population and technological development does not persist in a coherent form once the impact of industrialization and the world market begin to act on an agrarian economy. Transport technology and the operation of the market brings agricultural innovations to rural populations that may be adopted for other reasons than population pressure. Such other reasons are like "incentive" goods (World Bank 1990). Boserup (*ibid.*) notes that the forces of modernization on the part of the state bureaucracy or a particular ruling class are decisive. Nonetheless, Asia is more likely to develop faster technologically than Africa because of its denser rural population who face land shortage and dispossession of their means of rural livelihood. The process of proletarianization combined with a long urban tradition are more conducive conditions for industrialization than those prevailing in more sparsely populated African continent (Bryceson 1985). Boserup concludes that with the right policies and perhaps more importantly the right "administrative technology" (translated by Bryceson (1985) to mean "social division of labour") a simultaneous agrarian and

industrial revolution is within the reach of the developing world. The short- and medium-term bottlenecks that arise in the development of technology and the social division of labour are surmountable over time. Figure 2.2 shows the Boserup's virtuous circle representing interrelationships between food supply, population change and technology.

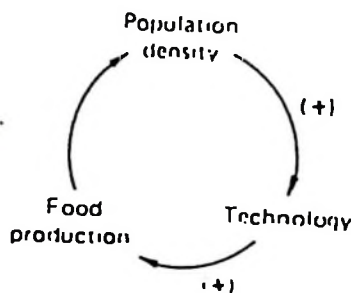

Figure 2.2. Boserup's virtuous circle showing the relationship between food supply, population change and technology. Adopted from Bryceson, 1985, p. 16).

2.1.8.5 Economic strategies for agricultural development

Basically two development strategies have been advanced for the agricultural sector namely, unimodal and bimodal types (Johnston & Kilby 1975). Whereas the unimodal type refers to a progressive modernization of the entire agricultural sector, the bimodal or dual structure concentrates resources in the highly commercialized sub-sector (*ibid.*). While sometimes these are considered to coexist, Johnston & Clark (1982) maintain that they are mutually exclusive because "promoting the emergence of a large highly commercialized sub-sector tends to preclude the possibility of successfully pursuing a unimodal strategy". They argue that the majority of farm households are inevitably by-passed when a bimodal pattern of agricultural development is pursued. In light of these two strategies, the situation in Tanzania has been as follows:

At independence in 1961, Tanzania basically had a dualistic economy comprising of a peasant sector and large scale plantation agriculture. The latter group was a result of the "focal point

approach encouraged by the British colonialists in the 1950s (Coulson 1981). The main consequence of this dual pattern was the increasing inequality between the small and large agricultural sectors (Tibaijuka 1984). After independence, with assistance from the World Bank two approaches known as "improvement approach" and "transformation approach" were adopted (*ibid.*). The "transformation approach", which preceded the other, is a bimodal pattern involving the opening of government financed highly capitalized new settlement schemes in rural areas. The "improvement approach" is a unimodal strategy involving a gradual approach supported by extension programs to assist farmers to improve their farming methods within the existing traditional structure (Coulson 1981). Both systems proved unsuitable in Tanzania and were later replaced by the "Ujamaa villagization policy" which was basically a compromise of the two and aiming at bringing development by encouraging self-reliant economic activity based on cooperative effort through mobilization of people (Omari 1976, Tibaijuka 1984).

The "Ujamaa" policy has also virtually failed and now the bimodal approach seems to be in practice again (EIU 1994). Ironically, the tendency is to preach the unimodal approach and implement the dual approach (*ibid.*). In any case it is economically costly to adopt the bimodal strategy because large scale farming based on imported inputs is less efficient for developing countries (Omari 1976). These countries should invest more in rural agricultural programs to raise productivity and hence overall economic growth.

In the area under study, agricultural productivity can be improved by adoption of new technologies. However, adoption of new technologies relies on the availability of the required inputs. Often these are capital inputs which must be initially injected from outside the rural areas. At the farm level where this study is focused, capital is considered to be the most limiting resource and therefore must be optimally allocated. This type of setting brings us to the question of decision making and allocation of resources on peasant farms which this study envisions to analyze. Before narrowing our review to the farm level analytical framework, it is important to review the "Peasant household economic theory" and its application in analyzing peasant farming systems. This will increase the understanding of the features and main characteristics which underlie peasant behaviour which is a core in analyzing peasant agriculture and tropical rainforest degradation, the theme of this study. That is the subject of the next section.

2.1.9 Review of peasant household economics and its application

2.1.9.1 Background of peasant household economics

The theory of household economy was first put forward in the 1920s by the Russian agricultural economist, A.V. Chayanov. His theory is referred to as the theory of the drudgery-averse peasant because it centres on the choice between farm work and leisure, where farm-work is considered irksome or toilsome by the household (Ellis 1987). It emphasizes the influence of the family size and structure on household economic behaviour, via the subjective valuation of labour within the household. This theory has implications for the concept of peasant household production which go beyond the mere mechanics of its working as a microeconomic model.

In 1979 Barnum & Squire developed and applied a model of farm household based on the

concept referred to as "new home economics". This model provided the framework for generating predictions about the responses of the farm household to changes in domestic and market variables (*ibid.*). Nakajima (1986) also developed in an operational framework the Chayanov theory into a subjective equilibrium model which could be used for analyzing farm firms, commercial farms, farm households and subsistence farms (Holden 1991, Kaoneka 1993). Since then there have been several other applications of this theory some of which will be reviewed here in addition to theories which attempt to describe peasant behavior and characteristics.

2.1.9.2 The neo-classical theory of farm production

Theory of the farm firm

The theoretical basis for optimal resource allocation and product combination hinges upon the theory of the firm. This theory is often approached through neo-classical marginal analysis (Mansfield 1991). To grasp the neo-classical theory of farm production one can begin with a farmer as an individual decision maker who has possibility to vary the level and kind of farm inputs and outputs. Typically the economic decision making capacity of the farmer is encompassed by three kinds of relationships between farm inputs and outputs. These three relationships also provide guidance for the three main steps used in construction of the theory of the farm firm (Ellis 1987).

These are as follows:

- (a) The factor product or input-output relationship, also called the "production function".
- (b) The factor-factor relationship, also referred to as the "method or technique" of production
- (c) The product-product relationship also called "enterprise choice".

This threefold capacity of varying the way in which production is organized only attains analytical relevance when placed in the context of the goals of the farm household and the resource constraints of the individual farm. In practice farm families have many different goals and constraints of varying severity which limit the capacity to vary the organization of production (Low 1986). Hence the theory of the firm approached through neo-classical marginal analysis lends itself as a means to optimize resource allocation and product combination under the varying goals and constraints to which the farmer is subjected (Tibaijuka 1984). Typically the basic theory of farm production hinges on some important simplifications and assumptions with respect to goals and constraints in order to make the analysis and decision making possible through a production function which is discussed in the section which follows.

The production function: use in farm decision making and limitations

The basis of neo-classical analysis is the concept of the production function (Mansfield 1988). In general the production function in economics describes the technical or physical relationships between factors of production (variable inputs) and their corresponding outputs determined by technical and physical conditions within the firm. This is so no matter how many variable inputs are included in the function (Tibaijuka 1984). By assuming perfect competition and that the objective of the firm is to maximize net revenue, Baumol (1977) notes that the firm's

maximization of profits is achieved by determining the optimal mix of products (outputs) and factors (inputs). This is the equilibrium position which is determined by application of differential calculus. Based on microeconomic theory at equilibrium, the marginal rate of substitution between two products or between two factors is equal to the ratio of their prices. Also the marginal physical product of a factor with respect to a product is equal to their price ratio. Moreover, the quantity of a good produced is selected so that its marginal cost equals its price (Mansfield 1991, Gravelle & Rees 1992). Theoretically therefore the production function theory can serve as a basis for determining optimal production decisions of a firm including a farm firm (Mansfield 1991).

In practice however, there are a number of problems that stifle the direct use of the production function approach (Tibaijuka 1984). One problem is that the exact form and nature of production functions is not exactly known (Tibaijuka 1984). Furthermore it is cumbersome to construct a production function which takes into account all the relevant factors because if all the necessary factors (inputs) and products (outputs) were to be considered, the resultant computational work would be prohibitively big (*ibid.*). Besides, the traditional production theory often makes simplifying and sometimes unrealistic assumptions (Tibaijuka 1984, Ellis 1987). For instance, it is difficult if not impossible to separate and determine the importance or the effect of one input at a time on whole production (Carlsson 1981). Because of these limitations other techniques particularly mathematical programming based on constrained optimization has, in recent times, become quite popular in analyzing the firm's rational behavior (Dykstra 1984, Tibaijuka 1984, Mlambiti 1985, Mansfield 1991). How optimizing techniques are used is further discussed in section 2.1.10.

Concepts on behaviour and main features of peasants

Having reviewed the theory of the firm and the production function it is now important to review some concepts describing peasant behaviour and characteristics before discussing some theories which try to explain this behaviour. The review therefore concerns the construction of an economic definition of peasants who are the main object of analysis in this study. Understanding of the characteristics of peasants is important before an attempt is made to find out ways of improving their prospects or predict their behaviour. It is also important in that it facilitates yielding an accurate perception of the nature of peasant problems before analytical methods can be applied to solve their problems. The review presented here draws much from Ellis (1987) and other sources such as Wolf (1966), Chayanov (1966) and Nakajima (1986) among others.

According to Ellis, (1987) peasants can be defined by examining two aspects (a) some distinctive characteristics of peasant societies which set them apart from other social groups and (b) features of the peasant farm household which differ from other kinds of farm enterprise. In a wider context these are transition, exposure to market forces, subordination, internal differences, farming, access to land, family labour, ambiguity of profit and subsistence production (Ellis 1987). All these individual components are integrated by the concept of "partial integration into markets of peasants and limitations in the operation of market principles in the peasant economy (Friedmann 1980). These features and characteristics give peasants a definite identity with

dimensions of history, change, society, economic activity, and resource use. They also distinguish peasants from other kinds of rural producer, from rural and urban workers, and from capitalistic enterprises. Thus by bringing together the various components, a definition of peasants is found in their partial integration into incomplete markets. Thus Ellis (1987), defines formally the peasants as follows: "Peasants are farm households with access to their means of livelihood in land, utilizing mainly family labour in farm production, always located in a larger economic system, but fundamentally characterized by partial engagement in markets which tend to function with a high degree of imperfection". The emphasis in this definition is that peasants are not, like other farm enterprises, wholly or inextricably linked to the market economy. Their main factors of production namely land and family labour are not purchased in the market, and often they sell only a small proportion of their output to the often imperfect market.

Chayanov (1966), Nakajima (1986) Low (1986) and Ellis (1987) all view the dual nature of production of a farm enterprise as a central peculiarity of peasant production. The peasant unit of production is both a family and an enterprise which simultaneously engages in both production and consumption (Nakajima 1986). This dual economic character of the peasant household has implications for its economic analysis. Based on Ellis (1987) we review the main features of this economic unit which distinguish it from other economic actors in the market economy. The dominant economic activity of a peasant farm household is farming such that land is the main source of livelihood mainly by cultivation of crops and to a varying degree keeping livestock. This feature excludes other categories of rural dwellers such as landless labourers, plantation workers, squatters, pastoralist or nomads. However, in a wider context of peasant society, all these and numerous other crafts and trades are sometimes included in describing the economic activities and livelihood of peasant farm families (Ellis 1987).

Peasant farm households have access to land as a basis of their livelihood and thus are distinguished from landless labourers or urban workers (Chayanov 1966). In connection to this is the significance of non-market criteria in the allocation of land in peasant households. Hence in many peasant societies are found complex family traditional rights of access to land which prevail over and constrain the operation of freehold land markets (Ellis 1987). These traditional land rights are often inalienable, and transfers of land outside ties of family are rare even though markets do exist (*ibid.*). In consequence peasants view land as more than just another factor of production which has its price. Instead land is viewed as a long term security of the family against the hazards of life, and it is part of the social status of the family within village or community (Chayanov 1966, Tibaijuka 1984, Low 1986, Nakajima 1986, Ellis 1987, Kaoneka 1993).

One of the salient features of peasant agriculture is its dependency on family labour for farm production (Chayanov 1966, Low 1986, Nakajima 1986, Ellis 1987). Ellis (1987) observes that reliance on family labour is a defining economic characteristic of peasant households. This feature does not rule out the use of hired labour during peak periods of farm activity nor does it rule out the sale by members of the farm household of their own labour outside the farm on an "ad hoc" basis (*ibid.*). Indeed for some families this may be essential for survival (Low 1986). In peasant communities, the predominance of family labour in production also affects the way

labour markets function. The reason is that various subjective criteria peculiar to individual households often in the wider market, influence both the supply and demand for wage labour (Chayanov 1966, Nakajima 1986, Low 1986, and Ellis 1987).

At the farm level, labour input is determined by the equality of value marginal product of family labour with the wage rate. However, the low opportunity cost of peasant labour ties most of peasant household labour to agriculture only (Tibaijuka 1984). This implies that the peasant household economy has a utility function defined by family income and amount of family labour. Since the peasant farm household earns cash through utilization of its own family labour, then an increase in income is a function of family labour use and as income rises household welfare also increases. When the wage rate on the market is greater than marginal value product of family labour, family members who can secure opportunities for being hired will sell their labour to earn money income to increase household welfare (Low 1986). In Mhonda village, the use of hired labour is almost negligible because most peasant households cannot afford the cost of compensating hired labour. Kaoneka (1993) found similar situation in Lukozi village in the West Usambara mountains. Often peasant household labour is unskilled and in consequence has limited opportunities for alternative employment hence zero opportunity cost (Low 1986).

However labour brings disutility due to its physical and/or mental pains. It also generates indirect disutility by reducing leisure or free time (Nakajima 1986). Thus the household desire for more income to improve its welfare conflicts with the drudgery-averse behaviour of peasant household members (Holden 1991). Therefore, for the sake of maintaining a certain level of production there is often, a decision made within the household, regarding trade-off between leisure and income because time spent on leisure cannot be available for income generating activities (Ellis 1987, Holden 1991). This trade-off leads to what is referred to as "subjective equilibrium" of the peasant household economy (Nakajima 1986). This subject is further discussed later in this report. Ordinarily, the demand for labour in agricultural activities varies substantially between seasons such that climatic seasonality is the main cause of this uneven distribution of labour requirements over the year (*ibid.*). This implies that season-tied production activities translate into both surplus and shortages of labour during dry and wet season respectively. Labour use variation over the year is influenced by factors such as timing of operations, division of labour by age, sex and social status (Sankhayan & Øygard 1993). Typically most farm activities take place during the rain season than during the dry season (Kaoneka 1993). Thus climatic seasonality leads to uneven use of labour between seasons. Some crops growing during particular times of the year demand more labor than others and also some operations like weeding are more labour intensive than others. Social demands which detract or divert the use of labour also vary over the year and there may also be unequal division of labour between men and women (Rudengrén 1981).

Capital is often the most limiting factor of production in most peasant households hence constraints efforts to move to high efficiency levels of production (Tibaijuka 1984). Frequently peasants fail to get credit from the often highly bureaucratic lending institutions. Besides ignorance, the main reason is lack of collateral or security which lending institutions demand before they can give out a loan. This capital is often needed to purchase farming implements, fertilizer and pesticides (Coulson 1981). For the meagre capital available in a farm household purchase of capital inputs may have both production and consumption aspects. Hence coupled

with the dual nature of production it is difficult to distinguish profit from returns to family labour (Ellis 1987).

Peasant's consumption basis of livelihood is subsistence in nature and perhaps it is the most popular defining feature of peasants amongst economists (Ellis 1987). Subsistence refers to the proportion of farm output which is directly consumed by the household rather than sold in the market and peasants are often referred to as "subsistence farmers" in this context (*ibid.*).

One main reason why the integration of peasants into the economy is only partial is because of a high degree of subsistence compared to output sale proportion (*ibid.*). At times however, peasant households can produce commodities and still qualify to be called peasant households on the basis of criteria other than consumption alone (Wolf 1966, Ellis 1987).

The theory of optimizing peasants

Under the "theory of optimizing peasant", peasant household economic behaviour is grouped into five alternative theories (Lipton 1968, Ellis 1987). These theories are: (a) profit maximizing peasant (b) risk-averse peasant (c) drudgery-averse peasant (welfare maximization) (d) the farm household peasant (e) share cropping peasant (*ibid.*). Each of these theories assumes that the peasant household maximizes one or more objectives (Ellis 1987). However, the central consideration in constructing a more complete theory of household behaviour is to achieve a more accurate representation of the multiple goals of the household, the interaction between the goals and the impact these goals have on the response of the household to changing circumstances (Ellis 1987). In the profit maximizing theory, there is only a single goal and economic responses are predictable provided that the assumptions of the theory are roughly met. In the risk-averse theory this single goal is modified, but not abandoned, and again responses are predictable subject to the impact on them of subjective responses to uncertainty.

In the full household theory the pursuit of various different goals in consumption may result in variable or unpredictable responses to different kinds of economic or social change. Thus a major aim of such theory is to clarify as far as possible the links between goals, actions and the outcomes of such actions (Ellis 1987, Holden 1991). One common limitation of these theories is that the household or family is treated as a single decision making unit with household head assumed to represent the goals of all household members. Also by assuming the orthodox approach that the household is ruled over by a patriarch, these theories neglect the social basis of the division of labour by gender in the household and also the differences in their command over resources and income (*ibid.*). The following sections will review these theories in terms of context, variants and extensions, approach and results of empirical validation, wider interpretation, policy implications and application in analyzing peasant agriculture.

The theory of profit maximizing peasant

The neo-classical hypothesis of this theory is that farm families in Developing Countries are "efficient but poor" and that "there are comparatively few significant inefficiencies in the allocation of the factors of production in traditional agriculture" (Schultz 1964). The neo-classical

economic theory identifies three kinds of efficiency namely allocative, technical and economic efficiencies (Mansfield 1991). According to Ellis (1987) technical efficiency refers to the maximum attainable level of output for a given level of production inputs, given the range of alternative technologies available to the farmer. Allocative efficiency by contrast refers only to the adjustment of inputs and outputs to reflect relative prices, the technology of production already having been chosen. Hence "price efficiency" is often used to describe allocative efficiency and this serves to emphasize its focus on the correct adjustment of relative prices.

Technical and allocative efficiencies are two components in the overall neo-classical concept of economic efficiency. While the achievement of either one of the efficiencies may be seen as necessary condition to ensure economic efficiency, the simultaneous achievement of both efficiencies provides the sufficient condition to ensure economic efficiency (Ellis 1987).

Peasant efficiency as a general hypothesis focuses on allocative efficiency which is substantiated by imputing a single desired operating position to the variable economic behaviour of individual farms. Ideas of partial or constrained profit maximization make sense given the widespread evidence of economic calculation among peasant farmers. Also by examining different positions on the efficiency question several policy implications can be recommended to improve the farmers efficiency through manipulation of prices, markets technology and extension service (*ibid.*).

The theory of the risk-averse peasant

Quite a high level of uncertainty typifies peasant agriculture. The issue of uncertainty and risk is discussed further in section 2.1.13, but the main types relate to natural hazards, market fluctuations, social uncertainty, state actions and wars (Tibaijuka 1984, Ellis 1987). It is always important to distinguish between uncertainty and risk in economic sense. Contemporary economic view is that risk is the probability attached by the individual to uncertain events. Hence it is the probability of occurrence of alternative outcomes in decision making (Palgrave 1987). Uncertainty on the contrary refers to situations where it is not possible to attach probabilities to the occurrence of events (Ellis 1987). Hence it is a descriptive term concerning the environment surrounding farm decisions where the likelihood of occurrence of events is neither known by the decision maker nor by anyone else (Mansfield, 1991).

The pervasiveness of uncertainties in peasant production has important implications for its economic analysis and for interpretation of its future prospects. Ellis (1987) observes the following effects of uncertainty on the peasant farmer:

- (a) It results in sub-optimal economic decisions at the micro level of the unit of production as compared to deterministic profit maximization
- (b) Results in unwillingness or slowness to adopt innovations (i.e. peasant conservatism)
- (c) Is the reason for various peasant farming practices, like mixed cropping, which represent successful adaptations to uncertainty by ameliorating its effects.
- (d) It reinforces social differentiation by having more severe impact for the poor than the better farm households.
- (e) It is reduced by increasing market integration due to improved information, communication,

market outlets etc.

- (f) It is exacerbated by greater market integration since the safety of subsistence is replaced by the uncertainties of unstable markets and adverse price trends.

Peasants tend to be either risk-averse, risk-neutral or risk-takers implying that they have subjective preferences between certain and uncertain alternatives in utility maximization in these attitudes to risk. Risk aversion may be defined as willingness to forego some income to achieve certainty and is characterized by a concave utility function of wealth (Roumasset 1979). In this context risk is what risk averters pay to avoid (Holden 1991). Risk-aversion results in different farm decisions from deterministic profit maximization. It causes the sub-optimal use of variable inputs such that the expected marginal value products (MVPs) of variable inputs are above the input prices. Consequently too little variable inputs are used so that profit and output are below their profit maximization levels (Ellis 1987). The aim of a risk averse farmer is to ensure that the household needs are covered in all seasons, even though profit is not being maximized except in "bad" seasons. There have been quite some research into the risk behaviour of peasant households but these studies are only referred to in section 2.1.13 of this report. Moreover, the policy implication of risk aversion are set out from these studies, for example irrigation and plant breeding for yield stability and crop insurance, price stabilization to cope with price uncertainties etc.

Theory of the drudgery-averse peasant (Welfare maximization)

This hinges most on the view of the dual character of the peasant household as both family and enterprise, consumer and producer with main focus on consumption aspect. Thus it describes the farm household theory which integrates the consumption and production decisions of the peasant family. The main idea is that the peasant is drudgery-averse because he chooses between farm-work and leisure where farm-work is considered irksome or toilsome by the household.

Consumption is described in this context on the basis of the consumer theory which uses the concept of "indifference curve" to describe a given level of utility (personal satisfaction) for different combinations of leisure and income (both treated as items of consumption). In figure 2.3 the consumer maximizes utility at the point of tangency of the "budget line AB with the highest attainable indifference curve, I_2 . Of special interest in this theory is the extent to which consumption decisions might alter the production responses of the household. In this connection the hypothesis that the peasant production possesses a special kind of economic motivation, different from other enterprises in the market economy comes forward. The drudgery-averse peasant model conforms in many respects with the analysis of peasant household behaviour first advanced in 1920s by A.V. Chayanov (Thorner *et al.* 1966).

The Chayanov farm household model

The uniqueness of household decision making in the Chayanov model is solely due to the lack of a labour market, and disappears when a labour market is introduced (Ellis 1987). This model is a theory of household utility maximization focusing mainly on the subjective decision made

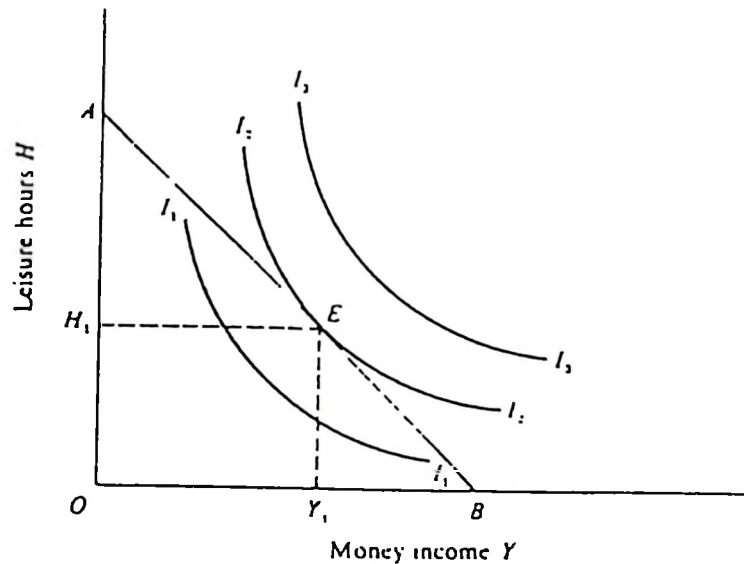

Figure 2.3 Indifference curve analysis of the choice between leisure and income.
Source: Ellis (1987) p. 104.

by the household with respect to the amount of family labour to commit to farm production in order to satisfy consumption needs (Holden 1991). The subjective decision is seen as involving a trade-off between the drudgery or irksomeness of farm work (disutility of farm-work) and the income required to meet the consumption needs of the household (utility of income). Hence the characterization of the theory as the theory of the drudgery-averse peasant (Ellis 1987).

The composition between working and non-working members in the household (i.e. the demographic structure of the household or the c/w ratio) is the main factor influencing this tradeoff. According to Thorner *et al.* (1966) the main assumptions of the Chayanov model are:

- (a) No hiring in or hiring out of labour by each household (i.e. absence of labour market).
- (b) Flexible access to land by each household
- (c) Farm output may be consumed or sold in the market, and is valued at market price.
- (d) Household motivation follows, in part, a social perception of the minimum acceptable level of material income.

It is from the first assumption where we deduce that the value of labour time and hence the

optimum level of labour use is a subjective matter which varies across households according to their demographic structure. This assumption also restricts the predictive power of the theory to the influence of family size and structure on labour time and output. Ellis (1987), summarizes the possible predictions as follows:

- (a) Higher labour input per worker as the consumer/worker (c/w) ratio rises.
- (b) MVP_L varies inversely with c/w ratio.
- (c) More land is cultivated as family size increases.
- (d) Average income per person in the household varies inversely with the c/w ratio.

The mathematical expression of the Chayanov model hinges on the inclusion of both production and consumption aspects of household decision making. The production aspect is handled by a production function

$$Y = P_y \cdot f(L) \quad [2.1]$$

where, Y = income, P_y = market price and L = labour input

The consumption side is represented by the utility function

$$U = f(Y, H) \quad [2.2]$$

where, Y = income, H = leisure, U = utility or happiness of peasant households.

The economic problem of the peasant household in the Chayanov model is to maximize utility subject to three constraints

- (a) the production function (b) the minimum acceptable income level (c) the maximum number of working days available. In simple notation:

$$\text{Maximize } U = f(Y, H) \quad [2.3]$$

$$\text{subject to } Y = P_y \cdot f(L) \quad [2.4]$$

$$Y \geq Y_{\min}; \quad [2.5]$$

$$L \leq L_{\max} \quad [2.6]$$

assuming that it is only the production function which is binding, the solution to this problem occurs where the marginal rate of substitution of leisure for income (the subjective wage) equals the marginal value product of labour. In simple notation this can be written as:

$$MU_H MU_Y = dY/dH = MVP_L \quad [2.7]$$

where MU = marginal utility.

One limitation of Chayanov model like other theories is that it does not separate roles of men and women in the peasant household. It assumes a patriarch run family with perfect male and female labour substitutability in farm production (Ellis 1987).

The farm household peasant: households decisions with labour market

This model examines the impact on the Chayanov farm household model of relaxing the assumption of a non-existent labour market. The household is now allowed to hire in or out labour. This has a dramatic impact on the logic of the farm household theory because it permits optimum production decisions with respect to labour use to be separated from optimum consumption decisions with respect to income versus alternative uses of time.

Figure 2.4(a) and (b) show what happens to the Chayanov model when the household is permitted to hire labour from outside to work on the family farm or to engage in off-farm work at the market wage rate.

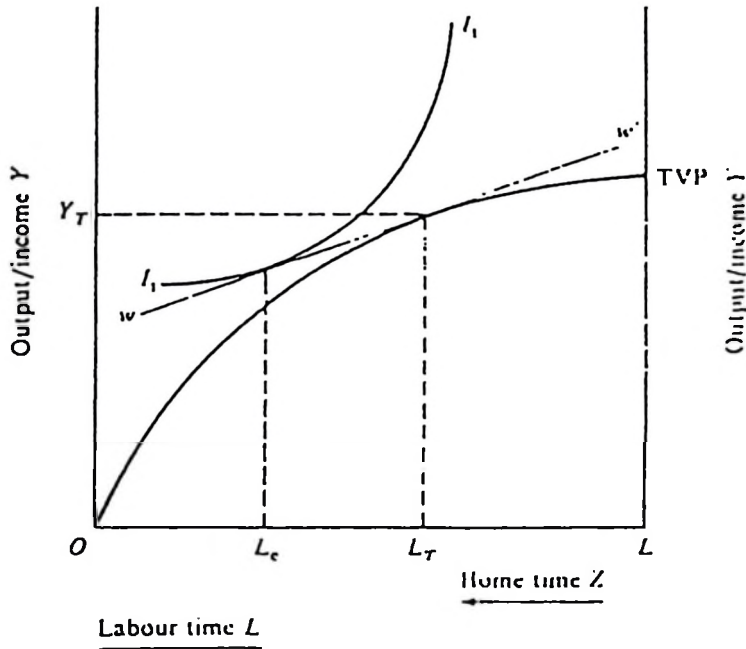

Figure 2.4(a) Farm household hiring in labour. Source: Ellis (1987) p. 121.

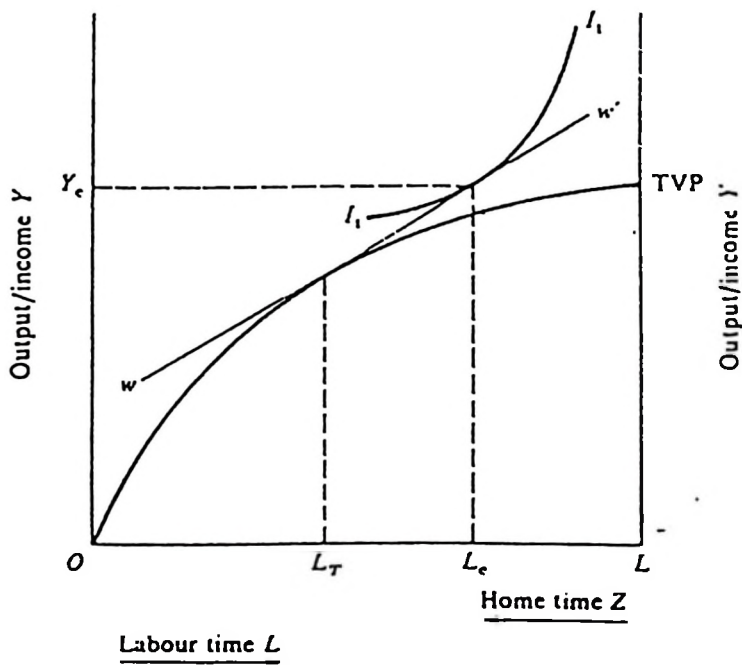

Figure 2.4 (b) Farm household hiring out labour. Source: Ellis (1987) p. 121.

In both cases due to the presence of the labour market, the wage cost line (ww') is introduced in the economic calculus of household decision making. This wage cost line represents the opportunity cost to the household of alternative uses of family labour time namely "home" activity (i.e. household non-farm activity), farm-work, or wage work off the farm. "Home" activity refer to what in neo-classical literature is called Z-goods (i.e. those goods and services produced within the household for direct use rather than for market exchange (Ellis 1987).

The impact of an external opportunity cost of labour time is that the valuation of labour by the household is no longer subjectively determined, and variable according to domestic family structure as in Chayanov model, but rather, it is given, and invariable (at least for static analysis), by the market. This permits a separation, within overall utility maximization between labour allocation related to the home time/income trade-off (i.e. the indifference curve), and labour allocation related to farm production (i.e. the production function).

This separation occurs because the household can now hire in or out labour at its opportunity cost which is the market wage. In consequence, the demographic determination of farm output and farm labour input disappears. Thus the existence of the labour market is crucial to how farm household model works and the kind of predictions it provides. It makes production decisions become independent of consumption decisions, and the response of the household to a change such as in the price of output becomes predictable and positive (i.e. a higher output price increases production and labour use) (*ibid.*).

The new home economics theory (Welfare maximization)

This is an extension of the general household economic theory with increasing application in fairly diverse situations (Holden 1991). The central feature in this branch of neo-classical economic theory is that the utility function is redefined in several ways such that it represents its preference ordering between a range of final characteristics of home produced goods and services. Hence a household is seen as a production unit which converts purchased goods and services as well as domestic resources, into a set of final use values yielding utility in consumption (Ellis 1987).

In this sense therefore, "Home economics" is concerned with the links between time allocation and utility maximization in the home. It provides the logical structure on which many farm household models are based. It treats the household as a production unit, in which the time of household members is combined with purchased goods or services to produce items of final consumption. All units of time, whether in house-work, wage-work, or leisure, are valued at their opportunity cost in terms of the market wage (*ibid.*).

The theory of sharecropping peasant

Sharecropping is a form of land tenancy in which the payment for the use of land, the rent, is the percentage of the total physical output obtained in the crop season (Ellis 1987). As a form of livelihood based on access to land it contrasts from traditional land rights, freehold land ownership and agricultural wage labouring. The economic decision making of the sharecropping

peasant differs in significant ways from the other theories in that it involves the interaction between households which differ in their command over land and other resources. At its simplest this interaction concerns land and is between households which possess land (land owners) and those which do not (landless share tenants). At its complex it is an interaction with multiple levels of contractual obligations between households involving land, credit, consumption loans, input prices, access to markets etc. In all cases it shifts the emphasis from the isolated decision making of the individual household to the nature of economic relationships between households. And in so doing it serves to highlight the wider village, community, or class dimension of the peasant production (i.e. more constraints) instead of down-playing them as in other micro-economic theories of peasant behaviour.

2.1.9.3 Comparison of the alternative theories and relevance to this study

The main features of the various theories are summarized in table 2.1 in terms of objectives, market assumptions, predictions, practical effects and policy conclusions.

Table 2.1 Main features of the various theories of peasant economic behavior. Source: Ellis, (1987) p. 160

Theory	Objectives	Market assumptions	Predictions	Practical effects	Policy conclusions
1.. Profit max	Profit max. (trad. prod. constraints)	Competitive markets	Price efficient	+ ve supply response	New resources New technology Education Credit schemes
2.. Risk-averse	Utility max. w.r.t. security	Natural hazards Social hazards Uncertain prices	Not efficient	Underuse variable inputs	Irrigation Price stab. Crop insurance Credit schemes
3.. Drudgery-averse	Utility max. w.r.t. income/leisure	Competitive product market No labour market	Not efficient	Ambiguous - subjective responses	Cooperatives Education (‘modernisation of the mind’)
4.. Farm household	Utility max. (general)	Competitive markets	Price efficient	+ ve supply response muted by gen. equil. effects	None <i>a priori</i>
5.. Share cropping	Profit max.	Interlocked markets	Tenant - not ‘efficient’ Landowner - ‘efficient’	Tenant - underuse variable inputs Landowner - interlocking for efficiency	Agrarian reform Tenant input subs. Tenant credit

Abbreviations: max. = maximisation, w.r.t. = with respect to, + ve = positive, stab. = stabilisation, subs. = subsidies, trad. prod. = traditional production, gen. equil. = general equilibrium.

The goal of policy intervention in peasant agriculture, with the exception of pure welfare policies, is to increase productive efficiency, output growth and peasant incomes (Mlambiti 1985). Implicit in this is to rescue peasants from the attributes which make them "peasants", whether this reside in household behaviour, in social norms, in technical constraints or in market conditions (Ellis 1987). From this viewpoint, the combinations between the theories which define the "most hopeful case" is the profit maximizing farm household peasant in competitive product and factor markets (*ibid.*). These theories conform with the objectives of the present study which is to improve peasant efficiency in production, increase output and incomes. On the contrary, theories about a risk-averse, drudgery-averse and share tenant peasant define the "most desperate case" which the aim is to decrease (*ibid.*).

2.1.9.4 Relevance of the household economic theory in analyzing peasant behaviour

The strength and relevance of the household economic theory in analyzing peasant societies is based on its ability to depict the behaviour of peasant farmers as a response to changes in some factors affecting household decision and hence behaviour (Holden 1991). Furthermore many features of farm households can be explained using the household economic theory. Based on household economic theory, several theories have been advanced to explain peasant behavior as discussed in section 2.1.9. These theories seem to have won wide applause and application (Ellis 1987). Among the important features of peasant households that lend themselves for analysis using the peasant household theory are peasant's heavy reliance on family labour and land and consumption pattern based on subsistence and how their behaviour change when exogenous factors change.

2.1.9.5 Complexity of peasant agricultural sector analysis

Agricultural systems are dynamic and highly complex systems (Mlambiti 1985). Besides internal interactions between the various components there are external factors influencing the system. A clear understanding of how peasant agricultural systems work is essential if these systems are to be improved. Cox (1972) argues that " a thorough understanding of the components of an agricultural sector is necessary to set realistic goals, to formulate an acceptable strategy and to develop and implement sound plans". Because of this recognition, economic analysis of peasant agriculture is today approached from an overall simplified farming system frame-work in which the production, financial, management and value sub-systems interact (Tibaijuka 1984). In the production system labour and other inputs available to a household are used to produce outputs which are then used either for own consumption or marketed. The financial resources so obtained are spent on further household consumption or purchase of operating inputs or investment in capital inputs. Indeed these ends are vital for the financial system because if they are not available the money has no value and marketing of the produce would be of no use (*ibid.*). The role of the management system is to foster efficient use of resources and the understanding of how the marketing function can be used to improve consumption. Values are the overall motivating factors that determine the desire for consumption and hence the desire to work or engage in the production process (Mlambiti 1985).

Figure 2.5 illustrates the causal diagram showing the complexity of a semi- subsistence peasant agricultural systems in Tanzania. The flow of income is given in money terms because the use of money as a medium of exchange is widespread and most important in the rural areas of Tanzania. Other forms of exchange such as barter system still exist but at very low scale and over time they have lost their significance even at local level (Tibaijuka 1984). It is assumed that the causal relationships in figure 2.5 are self explanatory and can be understood without additional explanations. However, the structure portrays an overwhelming complexity of the situation modelled. As can be noted there are many variables that need to be taken into account and a large number of these are difficult to measure. Besides, there is paucity of baseline data even on the variables that can be easily measured. Worse still there is a problem of defining the parameters that are involved. Under such circumstances the construction and use of system simulation models based on the logic and appeal of development planning becomes imperative (*ibid.*).

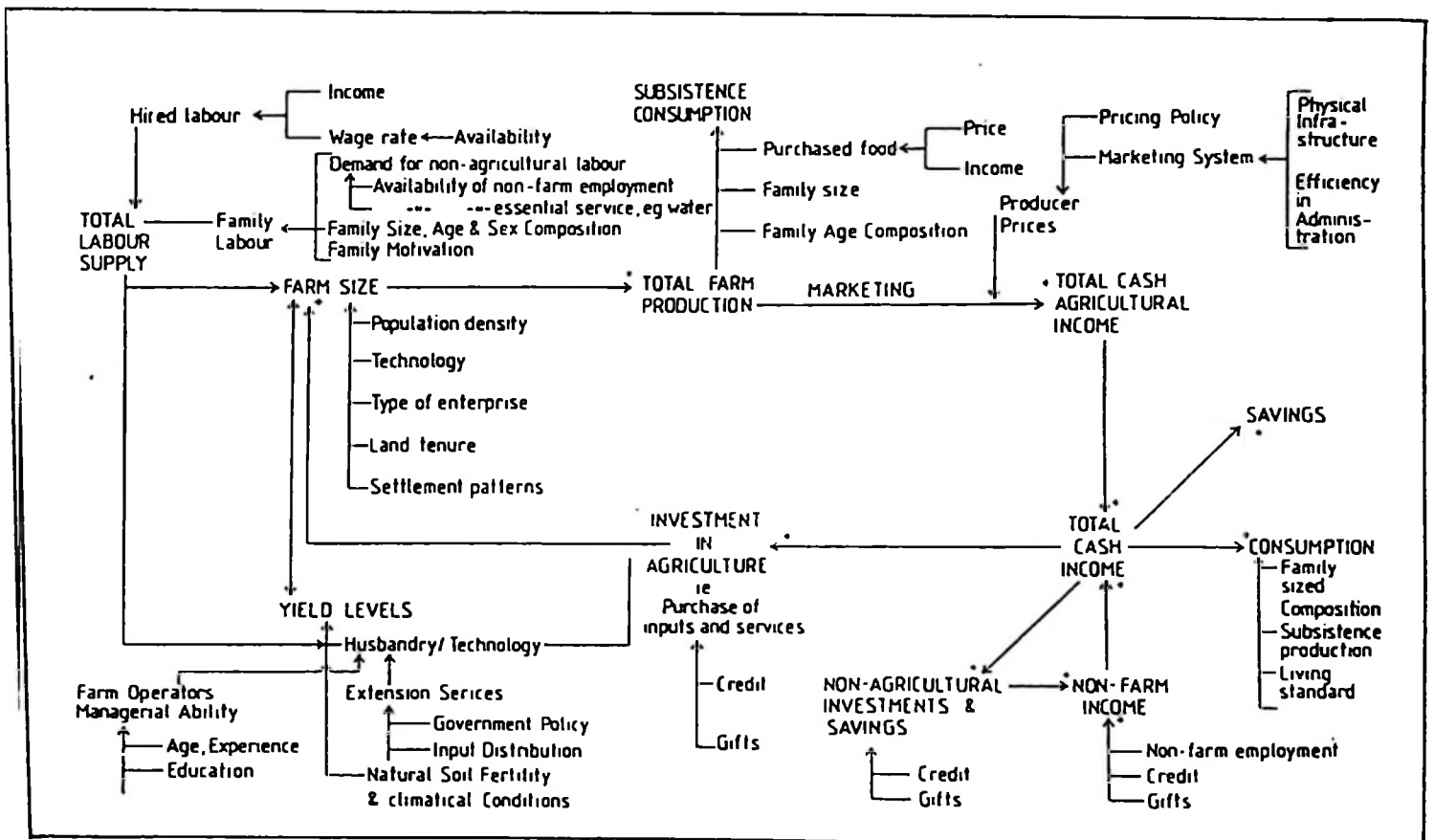

Figure 2.5. A causal diagram showing the complexity of semi-subsistence peasant agricultural systems in Tanzania. Source: Tibaijuka (1984) p. 38.

However, where baseline data is limiting, a simplified approach is recommended in lieu of system simulation modelling *per se*. Cox (1972) argues again that: " what is needed..... is a simplified system approach, that while less than perfect would allow the planners to view the whole system so that a large number of variables and their interactions can be considered simultaneously. By doing so bottlenecks and gaps in knowledge and action can be more readily identified, interactions estimated, institutional or organizational deficiencies pinpointed and alternative pathways considered".

Therefore in this study, the simplified approach will be adopted to cater for limitations in the available data which does not permit a simulation *per se* of the system. A simulation *per se* of the system would require a large number of simplifying assumptions and also the estimated coefficients of the system linkages would be highly imprecise, hence the whole simulation model would be rendered of little practical value. Since the main objective of this study is establish optimal or efficient farm plans based on appropriate technology for purposes of making policy recommendations, linear and nonlinear programming models are more appropriate and sometimes simpler for optimization or compromise of objectives. After all, simulation model do not provide one with optimal solutions. Instead they provide a series of solutions from which an optimal solution must be picked using other criteria (Kowero 1983, Holden 1991).

2.1.9.6 The multi-objective criteria in planning peasant farming systems

Earlier economic policies to transform peasant agriculture mistakenly viewed the maximization of profit or money income as the single most important objective of a peasant farmer in his capacity as a producer (Ellis 1987). Consequently when an African peasant responded to cash crop price increases with a backward bending supply curve he was branded irrational or lazy with a high leisure preference (Coulson 1981). Those who proposed such policies did not realize that the assumptions necessary for profit maximization do not hold in peasant societies (Low 1986). According to Tibaijuka (1984) these assumptions are: (i) the presence of efficient markets where goods can be exchanged (ii) the absence or low level of risk and uncertainty. The lack of efficient markets and impact of risk and uncertainty are among the prime causes of multiple objectives in peasant farming systems (Ellis 1987). As such it took some bitter lessons of experience for rural development planners to realize that the motivation dominating decision making and resource allocation in peasant agriculture is primarily the supply of food and other basic requirements for family subsistence (Heyer, Roberts & Williams 1981, Ellis 1987). Thus the peasant will consider other objectives after he has satisfied himself that his basic subsistence requirements have been assured. Earning cash might or might not feature at all in the objectives of a peasant farmer (Chayanov 1966, Tibaijuka 1984, Holden 1991).

However, following the partial integration of peasants in the market economy, today peasants crave to fulfill two main objectives: To meet family subsistence and to earn money income in order to meet cash requiring obligations (Barnum & Squire 1979). While the first is common to all peasants, the second is dependent on the level of integration of an individual household in the market - a factor influenced, among other things, by a household's attitude to modernization (Tibaijuka 1984). Thus the attitude of the peasant farmer to modernization and hence to price

changes depends on the position in the market integration continuum (*ibid.*). Studies trying to understand peasant societies have illustrated that peasants are not homogenous. Working with data from Tanzania, Rudengrén (1981) observed that peasants "include various groups of people, from those who are completely independent of external institutions and the national economy - primitive subsistence producers - to those who are completely subjected to the ruling class. They naturally respond differently to policy measures depending on their position on this scale. Some are responsive to economic incentives such as change in producer pricewhile others do not respond at all".

In Tanzania and many parts of Africa, peasant farming systems are based on the communal concept of land ownership and often group decisions or group interests may limit individual decisions (Lele 1975, Heyer, Roberts & Williams 1981, Mabbs-Zeno 1986, Bigegård 1980). This system is particularly important in Tanzania, where since the inception of the "Villagization Act" of 1976, the power to control all village resources and responsibility to plan and distribute those resources among individual members rests in the village governments (Omari 1976, Mlambiti 1985). Moreover, the decentralization of decision making in a household is another reason to this heterogeneity of peasant households (Ellis 1987). Wives and other members of a household usually enjoy considerable freedom in making production decisions of some specialized activities. A familiar case is food production in which women play a major role and hence a reflection of the failure of past rural development efforts which directed extension services to men while ignoring women who occupy a critical position in household food production (Bryceson 1985, Øyhus 1992).

Therefore due to the existence of multiple objectives in peasant agriculture, this study aims at applying multi-objective programming based on compromise approach to trade-off between specified objectives of the peasant farmer. This approach is more close to the reality of the peasant household decision making.

2.1.9.7 Context of peasant decision making and farm planning models

In an economic sense, peasant farmers are resource managers who try, through decision making, to manipulate their land, labour and capital to achieve their goals. Like in any decision making process, their action involve choosing between alternatives in light of their goals. Hence they try to optimize (i.e. make production decisions which best meet their objectives). Optimization stands at the core of business management and operations research (Baumol 1977). Thus planning peasant agriculture leads to examining the implications of reallocation of resources in the production process. It means evaluation of the consequences of some changes or changes in either the methods of production or in farm organization on total farm output and hence on profit (Dillon & Hardaker 1980). Due to the integrated nature of peasant farming, the level of competition or complementarity among farm enterprises is usually very high.

Consequently whole farm planning is often recommended and it basically involves three steps namely: (i) development of a farm plan (ii) testing the specified plan feasibility in terms of its demands upon farm resources, as well as consistency with institutional, social or cultural planning constraints and (iii) the evaluation of the particular plan in fulfilling the stated objectives (*ibid.*). By application of simulation models and mathematical programming, feasible optimal farm plans can be generated according to farmers objectives and constraints (Baumol 1977).

2.1.10 Mathematical programming in peasant agriculture planning

In this study mathematical programming is used at household farm level to generate optimal farm plans according to the farmer's objectives and constraints. Linear and nonlinear programming are two constrained optimization techniques whose procedure lead to a selection of that mix of activities which optimize the objective function(s) subject to a set of constraints. A comprehensive treatment of the LP model and its advantages and limitations has been presented by a number of authors such as Hedy & Candler (1958), Daellenbach & Bell (1970), Hardaker (1978), Young & Richard (1978), Dykstra (1984), Holden (1991) and Kaoneka (1993) among others. Moreover, the application of LP models to small holder agriculture has been done although at limited scale because of paucity of baseline data (Tibaijuka 1984).

Some studies include those by Odero-Ogwel & Clayton (1973) and Mukhebi (1981) who applied it to Kenyan smallholder agriculture. Sisay (1980) used it in Ethiopia, while Kamuzora (1978) applied it in Tanzania. Other documented studies in Tanzania are those by Dykstra (1980), Gillard-Byers (1984), Tibaijuka (1984), Mlambiti (1985), Mgeni (1986), Mlambiti (1992), and Kaoneka (1993). In this study, review of LP is limited to its main assumptions and limitations. The reader is referred to appendix 8 for a detailed review of LP. However, a detailed review of nonlinear programming whose application has been limited and compromise programming are presented. Risk and labour use variation which are stochastic variables in the model developed in this study are used in a quadratic form.

2.1.10.1 Assumptions underlying the LP model

A number of basic assumptions underlie the successful use of the LP model. Their violation may lead to completely unexpected results. Often they are incorporated in the computer packages based on the simplex algorithm. However, it is still important to review them to foster clear understanding and efficiency in using the LP model to solve resource allocation problems. These are as follows:

Linearity and additivity assumption

The LP model is a mathematical programming model in which the objective function and constraints functions (inequalities) have linear relationships (i.e. production functions are linear and of fixed proportion with the form $y = \min(a_1x_1, a_2x_2)$). Consequently LP model assumes competitive or otherwise fixed input and output prices and constant returns to scale in production

(Hillier & Liebermann 1986). Therefore costs and profits always rise precisely in proportion with the level of output (Tibaijuka 1984). For example if the number of kilogrammes of fertilizer is doubled in a given situation, the production will be doubled (Buijtenen & Saitta 1972). No interaction is possible in the amount of resources required per unit of output. Also there is no collinearity among the activities (Mlambiti 1985).

The divisibility assumption

This assumes that decision variables can assume any value, integral or fractional. Thus the resources and products are considered to be continuous or infinitely divisible (Dykstra 1984). This assumption implies that the optimal solution could suggest optimal production plans showing fractional unit of animals and machinery such as 2.5 cows and 2.5 tractors. This may cause difficulties in such types of production activities because it is impractical to have an optimal plan that calls for 0.47 irrigation dams etc. For activities such as livestock in which whole numbers are desirable, it may be possible to define the productive activity on a scale such that rounding to the nearest whole number makes only a minor change in the feasible optimal solution (Mlambiti 1985). Also integer programming can solve such problems. When the assumption of divisibility is violated by restricting some or all variables to integer values the LP problem falls in the domain of integer programming (Mgeni 1986). Another approach to overcome such problems is by additional computing and introducing more constraints and restrictions (Tibaijuka 1984).

The deterministic assumption

According to this assumption, there is certainty in information about technology, resources, strategies and their consequences (net benefits) resulting in a unique pay-off. This implies that all technical coefficients and the RHS in an LP model are known and constant thus assume one value. Thus no account is taken of risk - the possibility for change of these values. For example, yield is assumed to be constant. Obviously this is not a realistic assumption particularly in traditional environment where smallholder farming takes place. However if the idea is only to apply LP technique, then to some extent uncertainties, risk and randomness can be dealt with by means of sensitivity analysis on the parameters in the form of a formal experiment (Dykstra 1984, Tibaijuka 1984). Stochastic programming is another approach to handle this problem (Mgeni 1986).

Fixed technology assumption

This assumes that only one decision is required for the planning horizon hence the decision problem is a single stage problem and it is operative in a static environment as opposed to a multi-stage dynamic programming (Mansfield 1988). Furthermore it assumes that production requirements are fixed during the planning horizon. This implies that there is a net benefit per unit of each product or service regardless of the scale of production (Mgeni 1986).

It is because of these features that LP models are static in character. There are cases however, where the fixed technology assumption is violated such as in agricultural technology which may

sometimes change as a constant socio-economic development. Under such cases dynamic programming becomes appropriate to handle the situation (*ibid.*).

Non-negativity assumption

In LP models all activity levels must be assigned positive values at least equal to zero (Dykstra 1984). Often the algorithm used to solve an LP problem numerically will impose the non-negativity restriction (Daellenbach & Bell 1970). The non-negativity assumption helps to avoid ambiguous solutions such as negative hectares allocated to a particular crop. However, there are few cases where negative assignments can have practical meaning or validity, but these are rare. The usual practice is to avoid the use of negative values (Dykstra 1984). For example, the optimal temperature for storing biological specimen may be negative. However, to conform with the non-negativity restriction of the LP model one can use the Kelvin (K°) scale of temperature (*ibid.*).

2.1.10.2 Why LP is used in farm planning

The major objective of peasant farm planning is to apply an analytical framework to generate optimal farm plans with potential to bring about agricultural development to peasant farmers. Specifically it aims at finding out possible resource re-organization at smallholder farming level in order to optimize the use of resources for maximum cash returns while meeting subsistence needs of the household and to compromise between various household goals. The LP model can be a useful tool for such purpose.

One crucial factor underlying the LP analytical technique is the appropriateness of its assumptions in most large and small farm production. Hence it is capable of generating solutions for all relevant cropping and resource set combinations. It can estimate which farmer's resources are most limiting (hence critical in the production process). LP is also simple and quick to apply. Furthermore, LP model compels the researcher to think logically and systematically. It provides short run, normative solutions and if data is correct and appropriate, these solutions are precise and stable (i.e. robust). LP model's additivity and linearity assumption permit it to portray spatial relationships between activities and locations and because of its flexibility it allows consideration of the effects of various policies on the plan. The weak side of Linear programming is superseded by its advantages hence rendering it a useful tool of analysis.

2.1.11 Review of multiple objective programming (MOP)

2.1.11.1 Introduction

Most real-world decision problems involve multiple and conflicting objectives (Despotis & Siskos 1992). Such problems are in fact semi-structured in nature because simultaneous optimization of the objectives is usually unattainable due to their conflicting nature (*ibid.*). In peasant agriculture, peasant farmers ascribe to a number of objectives. Due to this multiplicity of objectives, peasant farm households frequently operate with a strategy of "balancing" or compromising these

objectives rather than optimizing them (Lipton 1968, Tibaijuka 1984, Ellis 1987). Such objectives include: to earn cash income to meet cash requiring obligations, to supply food and other basic requirements for the family subsistence and to minimize risk among others (Ellis 1987). The tendency to compromise these objectives follows closely Simon's "satisficing principle" which involves the practice of setting goals which represent an acceptable level of achievement (Simon 1959). In light of this situation, Compromise Programming (CP) in the MOP framework has in recent years been found useful as it provides an operational methodology for handling multiple objectives of farmers within the framework of traditional mathematical programming. (Zeleny 1976, Romero & Rehman 1984, Romero, Amador & Barco 1987; Sankhayan, Prihar & Cheema 1988, Zekri & Romero 1992, Sankhayan & Øygard 1993). However, except for the brief theoretical introduction of CP in the field of agricultural planning by Romero and Rehman (1984), the real application of CP methodology using MOP context to agricultural planning was pioneered by Romero, Amador & Barco (1987) who used the new methodology to tackle some problems found in agricultural planning in one part of Spain.

According to Despotis and Siskos (1992), agricultural planning is a wide management field which includes important problems of agricultural economics, such as land allocation and distribution, cropping pattern design, machine hours allocation, irrigation etc. In these problems CP in the MOP framework is nearly self-imposed since the objectives under consideration, such as business profitability, employment level in the rural sector, seasonality of labour, environmental benefits and water resources serving, are often competitive and require implicit or explicit trade-off decisions. An extensive review of agricultural planning problems and models in the context of MOP, mainly at the farm level, is given by Glen (1987). In this present study, an attempt is made to combine the conventional LP, Quadratic programming and CP technique in a MOP framework to model peasant agriculture in Mhonda village. Although the technique is fairly new, a theoretical review based on existing studies is a starting point for conceptualizing and developing the CP model for Mhonda village.

There are two prime reasons for applying CP technique in this study: First, to model the multiple objectives to which peasant farmers in Mhonda village ascribe. These objectives are maximization of net cash income, minimization of risk and minimization of labour use variation. In addition to other aspects this analysis aimed at investigating whether or not risk aversion causes deforestation through clearing of forest land for agriculture. The second reason for using CP was to elucidate the influence of various objectives on the farmer's behaviour. For instance, farmers react to risk conditions, labour variations and price changes all of which affect yield (farm output) and hence influence the objective function of the conventional LP model which is maximization of net cash income (i.e. gross cash income less cost of cash market farm inputs) while meeting household consumption requirements.

2.1.11.2 Multiple objective programming framework

Multiple-objective programming (MOP) also referred to as vector optimization ascribes to the multiple criteria analysis technique (Cohon 1978). It involves simultaneous optimization of several objectives subjected to a set of constraints. Since an optimum solution for two or more conflicting objectives cannot be defined simultaneously, MOP seeks to find the best of efficient

solutions, also called non-dominated or Pareto-optimal solutions (Romero, Amador & Barco 1987). Hence MOP replaces the notion of optimality (which embraces strong normative implications) by this concept of efficiency or non-dominance (Romero & Rehman 1984).

MOP gives a set of efficient solutions which shows the levels reached for each objective and also provides information to calculate the trade-offs between them (Romero and Rehman 1984). The elements of the efficient set are feasible solutions such that no other feasible solution can achieve the same or better performance for all the objectives and strictly better for at least one objective (Romero & Rehman 1984).

MOP has the advantage that it requires no information concerning the preferences of the decision maker in order to construct the model except which variables are involved. It also provides valuable insights into the functioning of the system being modelled (Cohon 1978). According to Romero, Amador & Barco (1987) the efficient set of solutions in the MOP approach can be generated or at least approximated by using any of the following methods: First method is the weighting method in which each objective is weighted and summed. The efficient set is obtained by parameterizing the weights. The second method is the constraint method in which one of the objectives is optimized while the others are specified as restraints. The efficient set is obtained by parameterizing the RHS of the objective placed as restraint.

The third method is the multi-criterion simplex method where all the extreme efficient points are obtained by moving from one extreme (efficient) point to the adjacent extreme (efficient) point. In this present study, the constraint method is applied. After the efficient set of solutions is approximated or generated by the MOP approach, vector optimization compromise programming (CP) technique is used in this study to select the optimal solution or the best-compromise set of solutions from the efficient ones.

2.1.11.3 Compromise programming application

In the context of technical exposition, vector optimization Compromise programming (CP) is a method of choosing a unique optimum from the set of efficient solutions to a given MOP problem (Romero, Amador & Barco 1987). The first step in CP involves establishing a "pay-off matrix" (Zekri & Romero 1992). The entries of this matrix are obtained by solving a series of single-objective LP problems where each objective is optimized in turn. For every solution so obtained the values of the remaining objectives of the problem are worked out as associated with that solution (*ibid.*). An example of the pay-off matrix is shown in table 2.2. The elements of the main diagonal in the pay-off matrix represent the "ideal point" which has optimum values for different objectives as its coordinates (Cohon 1978). When the objectives are in conflict, as happens in agricultural planning, the "ideal point" is often infeasible and therefore a compromise between the objectives being considered in the analysis must be established. CP defines or chooses the efficient solutions or feasible solutions closest to the "ideal point" as best-compromise or as the optimum depending on the measure of distance used (Romero, Amador & Barco 1987, Zekri & Romero 1992).

The ideal point is therefore useful only in serving as a standard against which all the compromise solutions can be evaluated (Sankhayan & Øygard 1993). In general therefore the pay-off matrix,

gives extreme cases of the solutions and also the solutions given often portray conflict between objectives. Consequently there is always a trade-off between objectives such that non-dominated or Pareto-optimal solutions points can be identified by compromise programming. The decision maker has then to decide which solution points to sacrifice in favour of another. In a hypothetical pay-off matrix (table 2.2) for the typical MOP problem with two objectives, the ideal point is represented by net cash income of T.Shs. 100 000 and minimum risk of T.Shs. 25 000. However this represents an infeasible solution due to the conflicting nature of the objectives and hence a compromise set of solutions can be found using CP.

Table 2.2 A hypothetical pay-off matrix for a typical MOP problem with two objectives.

Maximization of net cash income (T.Shs. ha ⁻¹)	Minimization of risk (T.Shs. ha ⁻¹)
100 000	50 000
0	25 000

Besides generation of a pay-off matrix, the second step in CP is to obtain the deviations, $d_j(X)$ between the j^{th} objective value and its "ideal value" and to normalize the same for consistent results when the units of measurement are not the same for the objectives under consideration (Zeleny 1982, Sankhayan & Øygaard 1993). The final step is to select the appropriate measure of distance and to obtain the compromise set of solutions as described above. Based on Cohon (1978), Zeleny (1982); Romero, Amador & Barco (1987); Sankhayan, Prihar & Cheema (1988), the operative structure of CP can be described as follows: When the j^{th} objective is maximized, the degree of closeness $d_j(X)$ between the j^{th} objective and its ideal value is defined as:

$$d_j = Z_j^* - Z_j(X) \quad [2.8]$$

also when the j^{th} objective is minimized, the degree of closeness between the j^{th} objective and its ideal value is defined as:

$$d_j = Z_j(X) - Z_j^* \quad [2.9]$$

In both [2.8] and [2.9] the variables are defined as follows:

d_j = degree of closeness

Z_j^* = ideal value, $j = 1, 2, \dots, p$.

Z_j = best compromise solution

X = vector of decision variables X_j

j = number of objectives

There are cases in which different units of measure are used for the different objectives. Zeleny (1982) points that in such cases, relative rather than absolute deviations must be used. In this study relative deviations are used. Under such circumstances, the degree of closeness is defined

as follows:

$$d_j(X) = \frac{Z_j^* - Z_j(X)}{Z_j^* - Z_j^*} \quad [2.10]$$

where, Z_j^* = ideal value for the j^{th} objective

Z_j^* = anti-ideal value for the j^{th} objective (i.e. the most distant point from the ideal point for the j^{th} objective).

The measure $d_j(X)$ is obviously free from any units because it is expressed as a ratio (Sankhayan & Øygard 1993). According to Sankhayan & Øygard (1993); Romero, Amador & Barco (1987) the CP model generates solutions denoted by L_p , where L is the distance between the ideal and the best-compromise solutions. For measuring the distances between each of the solutions and the "ideal point", CP uses the following distance function:

$$L_p(d, k) = \left[\sum (w_j d_j(X)^p) \right]^{1/p} \quad [2.11]$$

where,

w_j = weights given to different objectives representing their importance. These are subjectively assigned based on the researcher's experience or the deterministic subjective opinion.

p = value representing the importance attached to the deviation of each objective from its ideal value

d_j = weights the importance of the discrepancy between the j^{th} objective and its ideal value

In the Quadratic programming model, L_1 ($p = 1$), L_2 and L_∞ ($p = \infty$) metrics representing the longest geometrical and "Chebysev" distances, were used for generating the compromise set of solutions (define a sub-set of efficient set or the best-compromise set (Zeleny 1974). According to Cohon (1978), when the L_1 metric ($p = 1$) is used, the total deviations are minimized and when the L_∞ metric ($p = \infty$) or "Chebysev" metric is used, the maximum of individual deviations is minimized. This implies that when $p = \infty$, only the largest deviations counts. The entire best-compromise set or solutions fall between the solutions corresponding to L_1 and L_∞ metrics (Romero, Amador & Barco 1987). Therefore, basically the solutions generated through two LP models [2.12] and [2.13] represent in metrics L_1 and L_∞ characterize the bounds of the compromise set such that $1 < X < \infty$ for d_x (i.e. define a subset of the efficient set) (Zeleny 1974). The two sets of LP models solved to obtain the set of compromise solutions corresponding to L_1 and L_∞ metrics can be represented as follows:

$$(i) \quad \text{Min} L_1 = \sum_{j=1}^k \frac{w_j [Z_j^* - Z_j(X)]}{Z_j^* - Z_j^*} \quad [2.12]$$

subject to $X \in F$,

where, ϵ means subset and F is a feasible set.

(ii) Min $L_\infty = d_\infty$

subject to

$$\frac{w_j [Z^*j - Zj(X)]}{Z^*j - Z^*j} \leq d_\infty \quad [2.13]$$

and $X \in F$,

where, $j = 1, 2, \dots, k$.

Solving LP (i) for the L_1 metric ($p = 1$) (the "longest" distance geometrically) the best-compromise or closet solution to the ideal point is obtained. Similarly, for the L_∞ metric ($p = \infty$) the maximum of the individual deviations is minimized such that when $P = \infty$ only the largest deviations are considered (Romero, Amador & Barco 1987). For this metric the best-compromise solution is obtained by solving LP (ii) in which d_∞ represents the magnitude of "Chebysev" distance (Sankhayan & Øygard 1993). Given w_j , the entire compromise set of solutions can be obtained by solving for all "p" in the range 1 to ∞ . The choice "p" reflects the strength as to why it is important to make the maximal deviation from the ideal as small as possible (Zeleny 1976). The main intuitive appeal of the compromise set is that it does not require an articulation of subjective preferences (Lakshminarayan *et al.* 1991). Once the compromise set of solutions is generated by using different values to w_j and p , the choice is referred to the decision maker as there is no a priori a justification for choosing a particular solution (Sankhayan, Prihar & Cheema 1988). Also the approach is flexible in that it precludes a rigid specification of a full utility function. Therefore it allows a farmer or a decision maker to consider only that part of a utility function represented by the best-compromise solution set between the L_1 and L_∞ metrics (Hazell 1971).

Using CP technique the decision maker generates a compromise set which is close to the ideal point as possible. This often involves assigning subjective weights to the objectives to reflect individual preferences on the compromise set (Romero, Amador & Barco 1987). According to Zeleny (1974), the compromise solutions lie between L_1 and L_∞ metrics represented by L_x . The choice "x" reflect or is influenced by the need to make the maximal deviations from the ideal point as small as possible. This trade-off between objectives can be implemented using a trade-off curve (Figure 2.6) in which the Pareto-optimal frontier curve AE, the ideal point I, and solution points O and Y representing the metrics L_1 and L_∞ respectively are displayed to aid the choice maker. The compromise set is shown in figure 2.6. Points O and Y (L_1 and L_∞) represent the bounds of the compromise set for the two objectives. A sensitivity analysis using different weights (subjectively decided) can be used to test the stability of the solution set.

The choice of a solution set or metric between 1 and ∞ such as "x" is fairly difficult (Cohon 1978). Thus the ability of the decision maker to interpret the L_1 and L_∞ metrics becomes important.

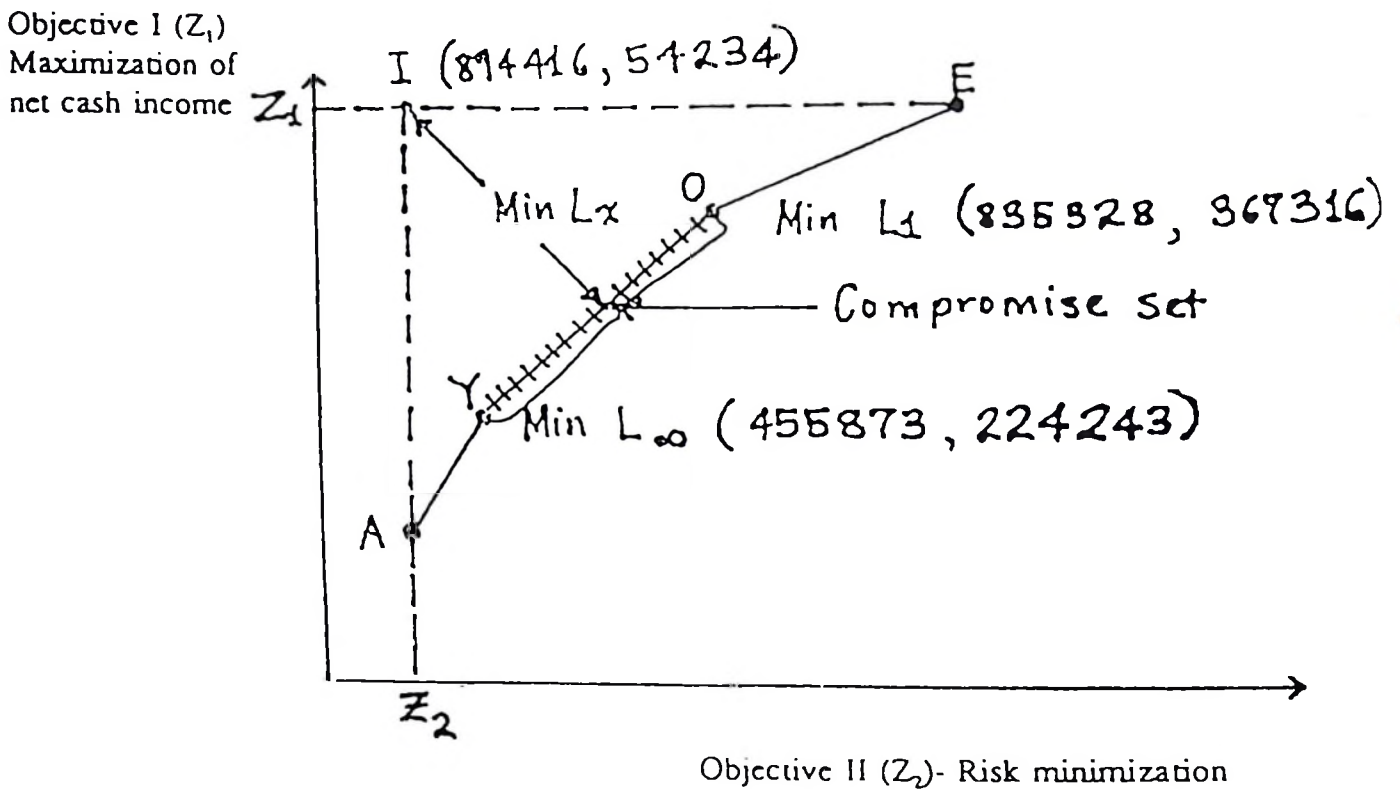

Figure 2.6 Trade-off curve showing the trade-off between objectives in the CP model (Adopted from Kaoneka 1993).

Table 2.3 A hypothetical set of solutions for the CP model

Gross margin (T.Shs. ha ⁻¹)	Employment (mandays ha ⁻¹)
10 000	30
10 000	25
8 000	40

Since in the absence of an objective measure, the decision maker has to discharge subjective value judgement. A hypothetical set of solutions in table 2.3 can be used to clarify the concept of an efficient set and the trade-offs involved. Row 2 represents an inferior set or non-efficient solution compared to rows 1 and 3. The third row is not dominated by the first. It has less gross margin but greater employment. Therefore the efficient set contains the first and the third row solutions. The theoretical review of CP presented here forms the basis for the CP model developed in this study to analyze peasant agriculture in Mhonda village. Since nonlinear programming is used in this study to optimize stochastic variables mainly risk and labour use variation, the next section presents a review of nonlinear programming, risk analysis and analysis of labour use variation.

2.1.12 Review of non-linear programming (NLP) model

2.1.12.1 Theory of quadratic programming approach

This review describes non-linear programming with particular attention to quadratic programming for farm planning under uncertainty. Quadratic programming as developed by Markowitz (1952 & 1959) for portfolio analysis have also been found to be appealing in farm management research but its use was hampered by the difficulty of handling it computationally (Hazell 1971). It has also been found to be a useful method for handling uncertainties (risks) in activity costs, yields and prices hence gross margins (Heady & Candler 1958, McFarquhar 1961, Camm 1962, Stovall 1966, How & Hazell 1968).

Due to the computational difficulties associated with quadratic decision criteria, the application of the technique depends on access to special computer packages with the desired features and capacity and also must frequently be performed on time series or cross-sectional sample data. Until recently there were few in existence (Hazell 1971) but now there are powerful systems such as the General Algebraic Modeling System (GAMS) developed by the World Bank. These have desired features and capacity to handle quadratic programming functions. GAMS is used in this study to model farming systems in Mhonda village on the basis of cross-sectional sample data. The quadratic programming model permits RHS and objective function uncertainty to be treated jointly or independently (Paris 1979 & 1989). Uncertainty in the objective function is treated on the basis of an E-V model. Uncertainty in the RHS part of the model is treated through application of non-linear duality theory (Boisvert & McCarl 1990).

2.1.12.2 Assumptions underlying the quadratic programming model

In its totality, the quadratic programming model is based on expected income-variance (E-V) criterion which assumes that a farmer holds preferences among alternative farm plans solely on the basis of their expected income E and associated income variance V (Hazell 1971). However this assumption is true if the farmer has an E-V utility function (McFarquhar 1961). As shown in figure 2.7 it also assumes that the iso-utility curves are convex or that the farmer is a risk averter. That is, along every iso-utility curve $\delta E/\delta V > 0$ (the farmer would prefer a strategy with higher V only if E were also greater) and $\delta^2 E^2/\delta V^2 > 0$ (this compensation must increase at an

increasing rate with increases in V). Given these assumptions a farmer rationally should restrict his choice among those farm plans for which the associated income variances are minimum for the given expected income levels. Quadratic programming aims at developing the set of feasible farm plans having the property that variance V is minimum for associated expected income level E . Such plans are called efficient E - V pairs and define an efficient boundary over the set of all feasible farm plans (Segment OQ in figure 2.7).

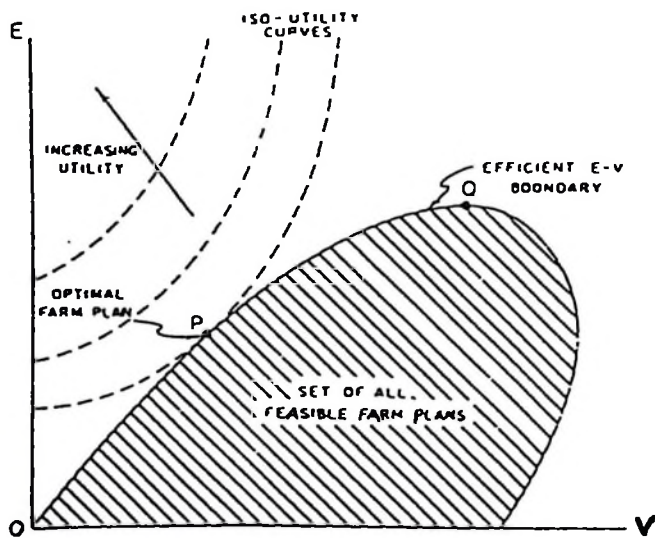

Figure 2.7 The optimal E - V farm plan. Source: Hazell (1971) p. 54.

2.1.12.3 Definition of the quadratic programming model for farm planning

According to Hazell (1971), short-run planning models assume constant farm overheads for the length of the planning horizon, consequently the income distribution of a farm plan is totally specified by the total gross margin distribution. Thus the quadratic programming model can be defined as follows in terms of activity gross margins:

$$\text{Minimize } V = \sum_{j=1}^n \sum_{k=1}^n x_j x_k \sigma_{jk} \quad [2.14]$$

such that

$$\sum_{j=1}^n f_j x_j = \lambda \quad [\lambda=0 \dots \text{unbounded}] \quad [2.15]$$

and

$$\sum_{j=1}^n a_{ij} x_j \leq b_i \quad [\text{for all } i, i = 1 \dots m] \quad [2.16]$$

$$x_j \geq 0 \quad [\text{for all } j, j = 1 \dots n] \quad [2.17]$$

where,

- x_j = the level of the j^{th} activity;
- f_j = the expected (forecasted) gross margin of the j^{th} activity;
- σ_j = the covariance of gross margins between the j^{th} and k^{th} activity when $j = k$ and the variance coefficient of gross margins for the j^{th} activity when j is not equal as k ;
- a_{ij} = the technical requirements of the j^{th} activity for the i^{th} resource or constraint;
- b_i = the i^{th} constraint level;
- n = the number of activities;
- m = the number of constraints;
- λ = a scalar. [2.18]

The sum $\sum_{j=1}^n f_j x_j$ is the expected total gross margin E , and $\sum_{j=1}^n \sum_{k=1}^n x_j x_k \sigma_j$ is the expected variance V . By parameterizing λ one can obtain a sequence of solutions of increasing total gross margin and variance until the maximum possible total gross margin under the resource constraints is reached. According to How & Hazell (1968) the solution for maximum λ is actually the LP solution for the forecasted gross margins. In the solution basis, solutions are obtained for critical turning points such that for the current total gross margin E , determined by λ , the variance V is minimum. These solutions are sufficient to define the efficient E-V boundary since efficient E-V plans for intermediate levels of E can be derived by applying linear interpolation on adjacent turning point solutions.

On the basis of a set of efficient farm plans so obtained, an individual farmer may accept any particular one depending on his preferences among various expected income and associated

variance levels as described by his E-V utility function. By measuring this utility function a unique farm plan can be rigorously identified which offers the farmer highest utility (McFarquhar 1961, Johnson 1968). This is the efficient farm plan indicated by point P in figure 2.7. When such utility functions cannot be specified the best approach is to develop efficient farm plans and allow the farmer to make the final choice. This approach is more flexible and avoids rigid necessity to specify the utility function. It also compensates for situations where income variance is not the best measure of risk. Moreover, This approach allows the farmer to freely choose the plan he most prefers in relation to a multiplicity of goals even under conditions when other socio-economic factors enter the utility function.

2.1.12.4 Data requirements of the quadratic programming model

The quadratic programming model (equations [2.14] to [2.17]) requires knowing apriori the mean gross margins for each activity ($f_j; j=1$ to n) and the corresponding variances and covariances ($\sigma_{j,k}; j,k=1$ to n). These parameters can be estimated using time series or cross-sectional data of observed gross margins (in this study observed cross-sectional data for households in Mhonda village is used). Sometimes it is possible to obtain subjective parameter values from the farmer. When both estimated and subjective parameters are available, the best practical compromise is to use estimated values at the outset and later make adjustments, if necessary, with available subjective information. Often estimated means and variance-covariance coefficients are generally regarded as either subjective or non-stochastic parameters in the quadratic programming model. Unless the original sample estimates are adjusted or confirmed by farmer expectations, however, such assumptions are not strictly valid. Covariance relationships, particularly when negative, are fundamental for effective diversification among farm enterprise as a means of cushioning against uncertainty (Feldstein 1969).

2.1.12.5 Standard estimation procedure of gross margins and income variance for the quadratic programming model

In the standard estimation procedure of variance-covariance coefficients and gross margins, the variance V in equation [2.14] is replaced by

$$\sum_{j=1}^n \sum_{k=1}^n x_j x_k \left[\frac{1}{s-1} \sum_{h=1}^s (C_{hj} - g_j) (C_{hk} - g_k) \right] \quad [2.19]$$

where $h=1$ to s denote s observations in a random sample of gross margins, and g_j is the sample

mean, $\frac{1}{s} \sum_{h=1}^s C_{hj}$, of gross margins for the j^{th} activity, ($j = 1$ to n) which may differ from the forecasted value f_j ; if subjective information is incorporated for these values. Taking the summation over h to the left and factorizing, the estimated variance is

9.8 How was the productivity trends in your plots during the past five years?

Year	1	2	3	4	5
Expected harvest (bags)					
Actual harvest (bags)					

9.9 Who decides crops to be grown?

- (i) Household head.....
- (ii) Spouse.....
- (iii) Both.....
- (iv) Other family members.....

10. LAND DEGRADATION

10.1 How long have you been using this farm holding?

- (a) < 1 year.....
- (b) 1-2 years.....
- (c) 3-4 years.....
- (d) 4-5 years.....
- (e) > 5 years.....

10.2 Have crop yields been decreasing?

If yes, by what proportion

- (a) By a quarter (25%).....
- (b) By one third (33%)
- (c) By a half (50%).....
- (d) By more than half (> 50%)
- (e) Other proportion.....

10.3 What are the causes of the decline in yields?

- (a) Soil erosion.....
- (b) Lack of fertilizer and/or manure to replenish soil.....
- (c) Drought and/or Floods.....
- (d) Poor farming techniques.....
- (e) Poor seed variety.....
- (f) continuous use of soil.....
- (g) Other.....

10.4 Is there soil erosion problem in your farm holding or around it? (a) Yes.....

- (b) No.....

10.5 If yes what are the causes?

- (a) Clearing of vegetation.....

(b) Inappropriate farming methods.....

(c) Other (specify).....

10.6 What changes in your village have you noted as a result of decreasing forest area?

10.7 What are the main reasons for forest disappearance?.....

10.8 How could the forest be managed in the best way?.....

11. LAND USE CONSTRAINTS

11.1 What are the most important constraints to land use? Indicate impact of each constraint.

(a) Lack of tools

(b) Erratic climate.....

(c) Lack of cash

(d) Late arrival of inputs.....

(e) Poor health.....

(f) Vermin and pest.....

(g) Poor seed quality.....

(h) Lack of production incentives.....

(i) Conflict among land uses.....

(j) Shortage of labour.....

(k) Land tenure system.....

(l) Population growth.....

(m) Low producer prices.....

(n) Ecological deterioration.....

(o) Government interference.....

(p) Other (specify).....

11.2 What improvements should the government make to minimize land use problems?

(a) Reduce price of farm inputs.....

(b) Raise producer prices.....

(c) Reduce price of consumer prices.....

(d) Provide credit for small farmers.....

(e) Reduce marketing problems.....

(f) Allow private ownership of land.....

(g) reduce government control on agriculture.....

(h) Other.....

12. FOREST AND TREE ISSUES

12.1 What products are obtained from the tropical rain forest? Indicate quantity harvested (m³,kg/week)

(a) Firewood

(b) Charcoal

(c) pitsawn timber.....

$$\frac{1}{s-1} \sum_{h=1}^s \left[\sum_{j=1}^n C_{hj} x_j - \sum_{j=1}^n g_j x_j \right]^2 \quad [2.20]$$

Now $\sum_{j=1}^n C_{hj} x_j$, is the total gross margin of a particular farm plan evaluated with observed gross

margins for the h^{th} sample observations, and $\sum_{j=1}^n g_j x_j$ is the total gross margin for the same farm plan evaluated with sample mean gross margins. Income variance can therefore be calculated with sample data either indirectly from the individual activity gross margin distributions as in equation [2.19], or directly from the total gross margin distribution as in equation [2.20]. This implies that when subjective expectations for the forecasted gross margins are available, equation [2.20] can be substituted as an estimate of equation [2.14] in the quadratic programming model.

2.1.12.6 Attractiveness of E-V criterion of the quadratic programming model

The advantages of the E-V criterion make it particularly attractive in farm management research. The attractiveness will increase even further following the availability of quadratic programming computer codes with the necessary parametric option and easier to handle. An example of such computer packages is GAMS. The data input file for the quadratic programming model for this study based on GAMS Software package is presented in appendix 6. The details of the GAMS package (Release 2.25) can be found in the User's guide. The strength of the E-V criterion lies in the fact that the E-V criterion conforms with the probabilities related to the likelihood of occurrence of different income levels for a given farm plan. In this criterion also, the variance V , is totally specified by the variance-covariance coefficients and in circumstances where subjective values of these parameters are available, the variance is no longer estimated from the sample of observed gross margin outcomes.

Moreover, the criterion is consistent with the Separation Theorem and allows more general solution to the farm diversification problem given a riskless option. This means that, the E-V criterion leads to more diversified production plans or investment portfolios than would occur if expected income or revenue were maximized (Boisvert & McCarl 1990). The reason is that a diversified solution involving more non-zero variables than the number of constraints may be achieved. The E-V criterion also allows examination of other important characteristics of the optimal solutions through the Kuhn-Tucker and Lagrangian conditions. Moreover the optimal shadow prices are "risk-adjusted" as are the optimal decision variable values (*ibid.*). One weakness of the E-V criterion has been problems in its application due to computing limitations. Most available quadratic programming computer codes with the necessary parametric option were until recently, of limited dimensions and uncertain performance. The question arises whether alternative criteria (such as expected income-mean absolute income deviation criterion) might not be available which have most of the desired properties of the E-V criterion but which are easier to handle computationally (Hazell 1971).

2.1.13 Review of risk analysis in peasant agriculture planning

2.1.13.1 Risk and uncertainty in peasant agriculture

Peasant farmers strive to meet their multiple objectives of subsistence production in an environment of risk and uncertainty (Ellis 1987). As the technologies used by peasants are invariably simple and there is little, if any, control on environmental variations, then exposure to risk and uncertainty is obvious (Tibaijuka 1984). Because of the importance of this subject several studies have been carried out to study the risk behaviour of peasants. Among them are: de Janvry (1972), Hiebert (1974), Wolgin (1975), Norman (1974 & 1977), Schluter & Mount (1976), Dillon & Scandizzo (1978), Lipton (1979), Roumasset (1979), Binswanger (1980), Bliss & Stern (1982), Binswanger & Sillers (1983) among others.

The definitions of risk and uncertainty in the economic sense are given under the theory of the risk averse peasant. However it is important to briefly give an overview of the nature of risks and uncertainties confronting peasant farmers. According to Tibaijuka (1984) and Ellis (1987) these can be grouped into the following headings:

- (i) Natural hazards such as weather, pests and disease and the other natural calamities.
- (ii) Market fluctuations such as in price changes and price uncertainty.
- (iii) Social uncertainty caused by differences of control over the resources within the peasant economy (i.e. interactions between landlords, tenants, money lenders, landless etc.).
- (iv) State actions or wars. This relates to the vagaries of decisions of agencies of the state.

To be able to survive, peasant farmers have developed farming practices which try to minimize these risks and uncertainties. The aim of a peasant farmer is not to maximize expected output in a statistical sense but tries to ensure that basic needs for the household will be met even in "bad" years (Low 1986). This implies that peasant agriculture is a flexible system which has adjusted to its uncertain and risky environment by trading efficiency for flexibility (i.e. minimization of risk if one of the crops fails (Coulson 1981, Tibaijuka 1984, Ellis 1987). There are several ways which peasants use as social security, insurance systems or risk minimization practices. These have developed over time and have therefore won the test of time in peasant cropping systems (Ellis 1987). Collinson (1972) and Coulson (1981) describe these various practices as follows:

- (a) Intercropping aimed at taking care of drought, diseases and pests. Drought, disease and/or pest resistant, high yielding but unpopular crops such as cassava are often intercropped with preferred staple food crops such as maize and banana. This is to ensure that some "return is gleaned from the efforts put into land preparation" in case of an unfavourable growth situation for the latter crops.
- (b) Staggered planting is widely used: to insure against early or delayed rains, and to flatten out seasonal labour peaks. It also enables the household to get fresh supplies of food in a situation where storage is difficult.
- (c) Fragmentation of fields which often serves as a measure to offset micro-climatic variations
- (d) Owning large numbers of livestock and sub-dividing that stock in different herds kept at different locations takes care of locational droughts and disease epidemics.
- (e) Diversification of crop varieties is a measure related to (d) in function. This is practiced by

planting many varieties of same crop in a single season or many varieties of different crops in the same season.

- (f) The traditional systems of work parties, matrilineal inheritance and extended family ties. Geisler, Keller & Chuzu (1985) and Holden (1988) observe that these three mechanisms are in the process of crumbling thus giving less social security to poor households.

These practices look rational and may be almost a matter of common sense. However, it has taken decades for researchers particularly agricultural scientists to grasp their logic (Tibaijuka 1984). Much effort was exerted by agricultural scientists to try to change these practices but ended in vain with failure to understand the farmer's reluctance (Coulson 1981). Extension officers tried hard to convince farmers to adopt monoculture, to plant early, to reduce the size of livestock herds (i.e. destocking) but with no success (*ibid*). The rejection of farmers to buy these ideas was interpreted as a sign of conservatism, ignorance and lack of ambition or desire for change (Omari 1976). Coulson (1981) notes that "the change of policy was rationalized by the use of ideology which described the African peasant as stubborn, lazy, ignorant, conservative, uncooperative.....failing to appreciate that there was often reason behind his refusal to cooperate with what the extension staff advised".

In Tanzania husbandry practices introduced by the colonial administrators were resisted by peasants. Later on those techniques were declared technologically wrong or inappropriate (Tibaijuka 1984). Tanzanian farmers equally resisted the villagization programme (1967-1976) introduced during implementation of the "Arusha Declaration" policies. Coercion was later used to resettle the peasants into permanent villages following the failure of voluntary shifting of the people (Omari 1976). However, it became clear later that the peasants resistance was rational because the programme caused immense environmental problems which offset any environmental advantages that the programme might have brought (EIU 1994). Today peasants have been allowed to return to their former sites (*ibid.*). The arguments made here do not imply that peasant agriculture is perfect and nothing should be changed or improved. The fact that some peasant farming practices are a handicap to agricultural development cannot be ruled out. The point advanced here is that there is always some good reasons for existing practices which have survived the test of time.

Thus a careful evaluation of the practices and understanding of the reasons behind them is essential for introducing acceptable improvement measures. Lipton (1979) observes that small farmers are reluctant to accept new practices which involve more risk although these might be offering prospects of more and/or better food and higher cash income.

Risk and uncertainty is a very important issue in this study because both efficiency (through optimization) and flexibility (through minimization of risk and labour use variation) are central to the analysis in this study. This emanates from the underlying assumption that resources are scarce and hence should not be wasted and that flexibility is important because peasant farming analyzed in this study is heavily dependent on the uncertain environment. Thus the objectives of this study will be pursued in light of the impact of risk and uncertainty among other variables.

2.1.13.2 Approaches for risk analysis in peasant agriculture planning

Linear programming (LP) is widely recognized as a method for determining a profit maximizing combination of farm plans that is feasible with respect to linear farm constraints (Hazell 1971). However, the conventional deterministic LP model ignores risk and hence may lead to a farm plan that is unacceptable to a farmer on the basis of previous experience. Because of the biological nature of agricultural production, there is always a significant amount of time between initial production decisions and the realization of output. This means that in reality there is potentially incomplete knowledge about all of the parameters of any programming formulation of agricultural decisions (Boisvert & McCarl 1990). It is widely recognized that a high level of uncertainty and risk typifies peasant agriculture especially in developing countries (Ellis 1987). Variations of climate and environmental conditions are at times very unpredictable and have severe impact on crop yields. Also markets are very unstable due to poor information and other market imperfections. Insecurity of poor peasant households due to low social and economic status and the vagaries of state action (i.e. unpredictable government policies) also affect agricultural prices and hence leads to wide seasonal cycles or swings in agricultural incomes and well-being of peasant farm households (Ellis 1987, Binswanger 1980, Boisvert & McCarl 1990). In some extreme cases, the outcome of risk and uncertainty events can often make the difference between survival and starvation (Ellis 1987).

Because of the risky and uncertain nature of peasant farming, peasants tend to operate through "disaster avoidance" as a central goal rather than economic maximization (*ibid.*). Lipton (1968) refers to this as the "survival algorithm" of the peasant farmers. This is also referred to as the "safety first principle" (Ellis 1987). In this sense peasants cannot afford not to cover their household needs from one season to the next since if they fail to do so they will starve. This is more important for a poor household existing at a bare subsistence level of production such that a loss means starvation. Consequently, in decision making, the farmer is constrained by the farmer's unwillingness to risk meeting subsistence needs and to obtain a net income below a given level unless the probability of yields falling below the minimum level is very low indeed. This makes the farmer's risk aversion behaviour a matter of survival (*ibid.*). The implication of the concept of risk in planning peasant agriculture is that unless the farmer's risk responses are adequately reflected in planning models, the results generated in empirical studies may bear little relevance and hence be of little or no use to the farmer and policy makers. Thus farm plans ignoring risk may be unacceptable to the farmer on the basis of his previous experience (Hazell 1971).

In agricultural economics, The normal practice is to distinguish between risk and uncertainty to the extent that risk is restricted to situations where probabilities can be attached to the occurrence of events whereas uncertainty refers to situations where it is impossible to attach probabilities to the occurrence of events (Dillon & Scandizzo 1978, Ellis 1987, Boisvert & McCarl 1990). According to Hazell (1971) risk may arise due to forecasted costs, yields and prices for individual activities, activity requirement from fixed resources or total fixed constraint levels. These affect the objective function and constraints of the conventional LP model. Hence these may be summarized as risks associated with gross margins (gross returns net of variable costs). On the

other hand the occurrence of a particular event is uncertain.

In the context of making subsequent discussions simpler, risk and uncertainty are used interchangeably to mean a situation where no single sure outcome is possible or that the outcomes are stochastic in the sense that the occurrence of events is random. Thus it is conceived that risk in this study connotes a situation where knowledge about future yields and product price is limited to estimates of possible outcomes. However, cost and levels of farm inputs are assumed to be fixed and known at the time of decision making, therefore they portray no risk condition demanding their inclusion in this analysis. In this study, risk minimization for peasant agriculture in Mhonda village forms one objective in the compromise programming based on the MOP approach. The risk elements considered in this study are those related to variability in yields and crop prices and both affect the objective function of the conventional LP model.

Theoretically, analysis of risk behaviour or its measurement is done under two approaches (Roumasset 1979, Ellis 1987). One approach is to treat probability and hence risk as variance either side of the expected average outcome of uncertain events. Hence reference is often made in the context of farm production to risk as the "income variance" which results from uncertain events. Variance is a statistical concept which measures the average deviation of a set of figures from their mean (i.e. is a measure of the dispersion of possible outcomes). Thus risk in this approach is the probability of events occurring which result in incomes above or below the average expected income in a succession of crop seasons. The second approach is to treat risk as the probability of disaster or chance of loss (i.e. the probability that the variable outcome of uncertain events will take on a value less than some critical minimum or disaster level).

Risk programming models are based on a number of decision criteria. First criterion is the direct application of expected utility theory which attempts to identify a single optimum decision given the utility function. The second criterion is consistent with expected utility maximization but only identify efficient portfolio of decision alternatives. The third criterion is based on more *ad hoc* decision making environment (*ibid.*). In this study the second criterion is used to identify efficient points which reflect the expected maximization of net cash income within the varying environment (hence constituting elements of risk for crop yield and crop prices). This approach often called Risk Efficiency Analysis (REA) is based on the expected utility maximization framework and does not require full specification of the utility function. REA assumes that all individual's preferences can be represented by a utility function. An efficiency criterion is a decision rule that provides a partial ordering of choices for the decision makers whose preferences conform to a specified set of conditions placed on the utility function (King & Robinson 1981).

Therefore in general terms REA involves imposing a set of conditions, or restrictions, on utility functions and/or the probability distributions of the choice set. Then for prospect A to be preferred to prospect B according to the risk efficiency conditions, the expected utility of A must be greater than the expected utility of B, for every utility function satisfying the restrictions (Boisvert & McCarl 1990). Such REA criteria are sufficient conditions for expected utility maximization for that set of conditions. The efficiency criterion is an optimal criterion if it is

both a necessary and sufficient condition for expected utility maximization. An optimal efficiency criterion minimizes the efficient set of choices by discarding those that are inefficient (i.e. those that would never be preferred) by an expected utility maximizer in the group of decision makers defined by the restrictions on the utility function). Any further reductions in the efficient set require further restrictions on the admissible set of utility functions.

According to Boisvert & McCarl (1990), most applications of risk programming technique require the analyst to choose the key elements of risk to be studied and this in turn determines which parameters of the model (such as the objective function coefficients, technical coefficients and RHS) are to be considered uncertain. The next step involves developing a probability distribution (or estimate moments of the distribution) for selected parameters and determine how these distributions and behavioural responses to risk can be adequately represented in the model. These distributions may be based on sample data or subjective information. However, mathematical models usually treat them as if they were population distributions (hence known with certainty).

Quadratic programming has been suggested to be a useful method to handle gross margin uncertainty in farm planning (Hazell 1971). It is based on expected income-variance (E-V) criterion and must be performed on time series or cross-sectional sample data.

In effect the E-V approach entails a tradeoff between expected returns and risk, as measured by the variance (or the standard deviation) of returns (Boisvert & McCarl 1990). This model is concerned with objective function coefficient uncertainty. Thus the major source of risk that are manifest in the objective function as variability in gross margins for individual crop and livestock enterprises are farm prices, and yields (Hazell 1971). The E-V criterion can be stated as: if A and B are two uncertain actions, and $\mu_A \geq \mu_B$ while $\sigma_A^2 \leq \sigma_B^2$, with at least one strict inequality, the A is preferred to B. By plotting each action in mean-variance space, the efficient set of actions can be identified as all those that maximize μ for a given σ^2 , or minimize σ^2 for a given μ (i.e. efficient farm plans are those with minimum variance or standard deviation for given expected income levels) (Boisvert & McCarl 1990). The general algebraic formulation of the E-V model has been presented earlier.

2.2 Literature on some previous studies based on the application of peasant household economic theory and mathematical programming

Nakajima developed, in an operational framework, the Chayanov household economic theory into a subjective equilibrium theory (Holden 1991, Kaoneka 1993). His subjective equilibrium principle hinges on the assumptions of Chayanov that a peasant household relies heavily on family labour for farm production and that the opportunity for hired labour is limited or absent due to lack of cash income. The main objective of the peasant household is to maximize the utility of family labour. Based on the general theory of household economics and utility theory, Nakajima defines the subjective equilibrium theory with the main contention that "each peasant household works to the point where household's subjective evaluation of the marginal disutility of work equals its estimate of the marginal utility of output gained" (Nakajima 1986).

The subjective equilibrium model can be extended to household farm activities as confronted with

variable rather than fixed conditions and one of these variable conditions is in labour use variation over the year. Thus the subjective equilibrium of the peasant household economy can be used to analyze the allocation of family labour to various activities over the year in the quest for maximizing the utility of family labour (Nakajima 1986). In notation form, the subjective equilibrium equation may be reformulated as follows:

$$U_M P_X F_A = -U_A \quad [2.21]$$

where,

the term $U_M P_X F_A$ represents the marginal utility of family labour with respect to cash income and $-U_A$ represents the marginal pain (i.e. disutility) of family labour.

The symbols represent the following:

U_M = marginal utility of money income = $-U_A/P_X F_A$

P_X = price of farm produce which is produced according to the function $f(A,B)$ (where X = product, F = amount of farm output by family labour, A = total amount of a family labour and B = land)

F_A = production of farm output as a function a marginal increase of family labour A ,

$F_A = dF/dA > 0$

M = money income from family labour.

A graphical presentation of Nakajima's subjective equilibrium theory in utility and income space is shown in figure 2.8 where the line hh' represents the maximum attainable income.

In an alternative way, Nakajima also presented the subjective equilibrium theory in graphical way based on utility and labour space as shown in figure 2.9. The aim was to make the equilibrium theory conform more to the neo-classical economic theory, (Holden 1991). In this figure 2.9, the line HH' stand for the upper limit of the family labour force.

Barnum & Squire (1979) developed and applied a model of a farm household which closely follows the logic of the "new home economics". The main difference lies in that this model deals with a farm as well as a household (Ellis 1987). Thus the production function refers to tradeable farm outputs and not just to "home" production for direct use. Also there is a possibility for hiring labour in and out at market wage. This model provides a framework for generating predictions about the responses of the farm household to changes in domestic and market variables (*ibid.*). After calibrating the model they applied it to examine the response of the average farm household to both domestic and market changes for a sample of paddy growing farm households in the Muda River Valley in Malaysia. They found that response predictions of the model were in line with reality (Ellis 1987). The assumptions of the Barnum & Squire model are as follows:

- (a) there exist a market for labour.
- (b) Land available to the farm household is fixed.
- (c) "Home" activity (i.e. production of "Z-goods" and "leisure") are combined and treated as the same consumption item for the purpose of utility maximization.
- (d) An important choice for the household is between own consumption output and sale output in order to purchase non-farm consumption needs.
- (e) Uncertainty and risk are ignored.

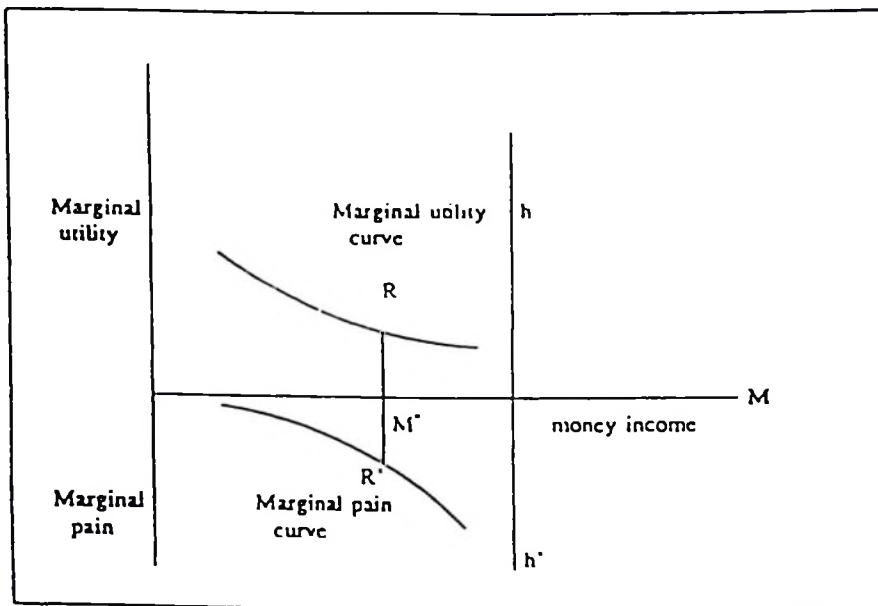

Figure 2.8 Graphical presentation of Nakajima's subjective equilibrium theory in utility and income space. Source: Kaoneka (1993).

The other symbols in the figure are defined as follows:

R = marginal utility curve

R' = marginal pain curve

M = money income from family labour.

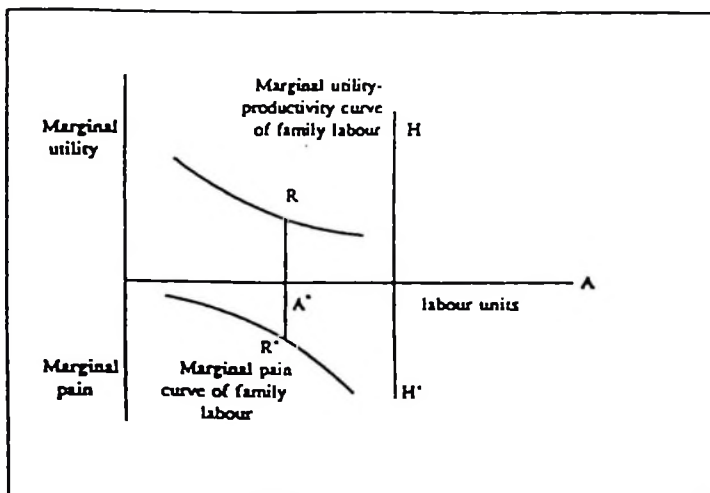

Figure 2.9 Graphical presentation of Nakajima's subjective equilibrium theory in utility and labour space. Source: Kaoneka (1993).

In this model the utility function embodies three goals namely: time for the production of Z-goods and for leisure combined (T_z); home consumption of output (C) and purchased goods (M). These also give three parts of trade-offs between goals. The utility function is expressed as:

$$U = f(T_z, C, M) \quad [2.22]$$

With preference between these influenced by the size of the household and its structure, the production function is

$$Y = f(A, L, V) \quad [2.23]$$

where, A = land under cultivation (presumed fixed)

L = total labour (both household and hired)

V = other variable inputs into production.

Utility is maximized subject to the production function, a time constraint and an income constraint. The time and income constraints can be collapsed into a single expenditure constraint, F' , as in "home economics model". In augmented form of the "full income" concept the joint constraint is

$$F' = wT_z + pC + mM = \pi + wG \quad [2.24]$$

where,

wT_z = opportunity cost of the time spent on Z-goods production

pC = market value of home consumption of output

mM = value of market purchases

π = profit or net farm income

wG = implicit value of total household time

The equilibrium condition of this model follows the standard microeconomic results for production and consumption such that:

(a) Marginal product of labour (MVP_L) = wage rate (w)

(b) Marginal product of other variable inputs (MVP_V) = their average price (v)

(c) Marginal rate of substitution (MRS) between home time (T_z) and purchased goods (M) = output price/purchased good ratio (p/m).

The existence of two pairs of consumption trade-offs and three resources in the production function renders the model unsuitable for single graphical presentation (Ellis 1987).

Barnum & Squire (1979), in their application to the sample of paddy growing farm households in the Muda River Valley in Malaysia, the size of responses to various household decisions to a one percent increase in an exogenous variable was quantified in form of elasticities. Thus with this model it is possible to estimate the way that an individual farm household would respond to a specified change in a single variable.

Furthermore, they found that the model could examine how these responses interacted in the larger economic system. For example, a rise in the output price was observed to increase greatly the demand for labour. But if hired labour was scarce, this increased the market wage, which in turn reduced total paddy output, and even more its market supply. The analytical strength of the Barnum & Squire model resides in its capacity to pursue the impact of joint production and consumption decisions within the household into the larger economic system. Hence it provides the basis for a general equilibrium analysis of the peasant economy in addition to the partial equilibria of the various components in the individual household (Ellis 1987). The major possible

weakness of the model is its dependence on an assumption of competitive markets for the applicability of the results (*ibid.*).

Tibaijuka (1984) applied the household economic theory, efficiency theory and linear programming to analyze the causes of decline in productivity and output of small banana farmers in Kagera region, Tanzania. The approach used in this study uses same assumptions and same utility function as Barnum & Squire (1979). Hence has capacity to analyze the impact of joint production and consumption decisions within the household and at regional level (i.e. larger economic system). Thus the study tried to analyze general equilibrium of the peasant economy at regional level in Tanzania. From farm management data and focusing on technological problems it was found that the continuing decline in yields of the staple food crops (banana and beans) was caused by factors such as pest outbreaks, injudicious use of pesticides and general decline in soil fertility due to population pressure. Consequently food shortage in the study area has caused the diversion of resources (land and labour) away from production of cash crops (coffee and tea) towards production of food crops for subsistence. This has resulted into cash scarcity and thus capital has become very limiting.

To ameliorate the situation Tibaijuka argues that the causal problem namely food shortage must be resolved. Using linear programming the analysis of choice of technology between peasant and improved production techniques showed that under the current level of resource supply peasant methods of production are more efficient and are to be employed. Improved techniques are limited by lack of capital. The study also reconciles the contradictions between Schultizian hypothesis that traditional agriculture is allocatively efficient and the contest by Shapiro that efficient differentials do exist in traditional agriculture. Rather than being contradictory these hypothesis are applied. Normative analysis shows that in the short run, for fertile but remote areas unaffected by pests, there is a scope to increase production by providing better incentives and making institutional reforms like removal of gender roles in the division of labour and granting women secure tenure rights. However, in the infertile densely populated, and pest ridden areas, no appreciable increases in production are predictable through a mere reallocation of resources. Technological improvements are critical and must be implemented concurrent with institutional reforms.

Low (1986) conducted a study aimed at explaining farm output stagnation in Southern Africa particularly in the countries of Swaziland and Botswana. The roots of this study are partly in Chayanov and partly in "New economics" models but Low study had different assumptions and emphasized on the Barnum-Squire model (Ellis 1987). Low's analysis focused on the choice between farm-work and off-farm work because they bear different income utilities to the household (Holden 1991). Thus the study used different market wage rates (w) for different household members, such that those members with the lowest off-farm wage earning potential (those for whom $w < MVP_L$) stay on the farm for subsistence production, while those with increasingly higher wage potential (i.e. those members for whom $w > MVP_L$) do off-farm wage work. Wage rates are measured in real terms (i.e. in terms of their purchasing power over retail food). Thus the proportion of household labour working outside agriculture is a function of money wage levels and the consumer price of food.

Thus according to Low, household members with low wage employment prospects will often be used to produce subsistence food crops in preference to non-food cash crops because they can produce more food than could be purchased with the proceeds of the cash crops they might otherwise grow. Cash crops may be more profitable than the production of surplus food crops for sale after household subsistence needs have been met. However, the employment opportunities of household members not needed to produce subsistence requirements will often be more attractive than cash cropping. This implies that cash crops need to provide better returns to labour than either subsistence crops valued at retail price or than the wage employment opportunities of the better-qualified household members if at all they are to engage in cash crop production. Concomitant to this is the finding that commercial crop production is more prevalent in regions where wage opportunities are limited and is more common among households which have low consumer/worker (c/w) ratio (Low 1986). Furthermore, the structure of the farm household had an important influence on the pattern of production as Chayanov assumed (*ibid.*). Low also stressed the significance of a labour market for the working of the peasant economy. The presence of the labour market, he notes, alters the internal logic of the household model and the way the household interacts with the larger economy.

One aspect is that the unique mode of economic calculation proposed by Chayanov disappears. Another is that the effects of an output price increase must be traced through both product and labour markets in order to gauge their impact on market supply. Low also explained the division of labour by gender through reference to "comparative advantage" in wage earning versus farm productivity. Whether the comparative advantage principle provides a satisfactory account of the social relations between men and women within the peasant household is still a matter of contention (Ellis 1987). The reason why Low used several weights for labour wage rates in his analysis was that they might vary among persons in the same households. For example, women often receive lower wage compensation than men who do off-farm work. Thus some household members have a comparative advantage in the labour market (Ellis 1987, Holden 1991). Ellis (1987) observes that the dominant feature of economic life in Low's study area was the proximity of a highly developed market for wage labour.

Consequently the conditions which concerned Low were as follows:

- (a) the existence of a labour market in which wage rates vary for different categories of labour and especially by gender as in Chayanov model but different from a single market wage rate assumed in the Barnum-Squire model. This implies that the different household members have different potential for earning wage income hence greater "comparative advantage" in wage work than others
- (b) An indigenous land tenure system which permits flexible access to land for farm households according to their family size as in Chayanov model but different from the fixed land assumption in the Barnum-Squire model. This implies that land input can be increased parallel with the labour input, thus deferring the onset of diminishing returns (as in Chayanov). Hence Low assumes constant marginal physical product of labour (MPP_L) over the relevant range for economic analysis.
- (c) Semi-subsistence farm households from which the farm-gate price of food differs from the retail price at which food can be purchased back from the market. This contrasts with the

single food price assumed in the Barnum-Squire model.

- (d) The wide spread occurrence of food deficit farm households with hiring out family labour. This contrasts with the conditions in forming the Barnum-Squire model of food-surplus farm households, which mainly, hire in more labour than they hire out.

Conditions (c) and (d) imply that for food deficit households the amount of labour to commit to subsistence food production depends not on the farm-gate price of output, but on the ratio of wages to the retail price of purchased food. In conclusion, Low's model shows the flexibility of farm household theory to adapt to alternative assumptions and to yield predictions pertinent to the varying circumstances which farm families may confront. Like in the Barnum-Squire model (inspite of the different assumptions) Low's model basic idea of optimum time allocation in the context of a household production function is found to provide a powerful tool of microeconomic analysis.

Holden (1991) combined the household economic theory and mathematical programming to analyze farming systems in Northern Zambia. While his work draws from Chayanov (1966) and Low (1986) it is much more based on Nakajima's (1986) subjective equilibrium model. the two hypothesis: "limited material wants" and "weighted income and leisure" were analyzed using Linear programming and Goal programming with the aim of generating and evaluating different technologies developed. The model includes risk/uncertainty and seasonality such that it holds at any one point in time. Furthermore seasonality in the model gives it possibility for substitution between time periods. Thus by inclusion of risk/uncertainty condition and preference Holden's new subjective equilibrium can be expressed as follows:

$$EU_M * E(P_x) * E(F_A) = -U_A \quad [2.25]$$

where. E = expected outcome

Other variables remain as defined earlier in this section.

Thus Holden argues that the marginal disutility of labour varies between different types of work because some tasks are more irksome than others. Consequently each type of work has its marginal pain curve and the subjective equilibrium problem may thus be to maximize total net marginal utility within each time period. Holden found that peasant behaviour has large variation between households in terms of basic resources such as cash and labour. Most of the variations are explained by the Chayanov model. He also found that the cash situation of households was influenced by access to off-farm income sources. Furthermore households practiced mixed cropping in order to increase returns from their limited resources.

Holden's study demonstrates the importance of mathematical programming as a useful tool in simultaneously handling and weighing important constraints and objectives against each other for typical model households. Further it stresses the need to frequently review models, calibrate and parameterize them and carefully interpret them without substituting them for human judgement. By combining mathematical modelling and household economic theory, Holden's approach conforms well with the real situation facing farm households. This is so because the approach uses economic principles to depict the behaviour of farmers as a response to changes in some factors affecting households whereas modelling is used to mimic the household farming systems

and simulate possible outcomes. Furthermore, the incorporation of risk and uncertainty increases the strength of Holden's approach since farming faces many uncertainties. For this reason Holden's approach draws close to the methodology of this study which aims at combining household economic theory and mathematical programming to analyze peasants agriculture in Mhonda village and pressure on deforestation.

Based on the general household economic theory and drawing from Holden's approach, Kaoneka (1993) combined the household economic theory, welfare theory and mathematical programming to analyze farming systems at village level in the Usambara mountains, Tanzania. The microeconomic theory was used to compute the profitability and returns to labour of the existing farming systems in the study area. Linear programming and compromise programming were used to optimize the use of resources and to compromise multiple objectives facing the peasant farmer. The effect of population growth on land use pattern, per capita cash income and consumption from own farm, and the effect of risk aversion on resource use were all analyzed.

The main assumptions in this study were that "no labour hiring in" due to lack of cash income but labour could be hired out. Access to land was fixed at least for the period under study. Retail food prices and labour wage rates were variable and capital was limiting factor. The model results and soil analysis were used to assess the sustainability of the existing farming systems in light of population growth and income constraints. Results of the study showed that population growth created considerable pressure on forest lands especially where arable land is limited. Most of the other findings conform with earlier similar studies. The study concludes that the existing farming systems are unsustainable due to ecological degradation. Also risk aversion causes farmers to produce sub-optimally. The present study draws on the approach used by Kaoneka but uses a different methodology in a different study area. Moreover this study goes further in analyzing deforestation pressure as a consequence of farming practices, risks and growing population.

2.3 Cost-benefit analysis in peasant farming

On the basis of neoclassical welfare economics cost-benefit analysis (CBA) connotes " a systematic method of identifying and measuring the economic benefits and costs of a project or programme" using a common yardstick (Munasinghe 1992). It is however a simple criterion when the number of alternatives are limited. Since it is based on the neo-classical welfare economics which is concerned with the total welfare of society, the CBA evaluates alternative projects or actions on the basis of changes in social welfare (Dixon *et al.* 1986). A number of important assumptions are implicit in this approach. These include: (i) societal welfare is the sum of individual welfare (ii) individual welfare can be measured in terms of units of utility as reflected in the prices paid for goods and services (iii) individuals maximize their welfare by choosing that combination of goods, services and savings that yields the largest possible sum of total utility given their income constraints.

When valuing environmental effects subject to an income constraint the following assumptions are also important (Dixon *et al.* 1986). (i) Utility and welfare can be obtained from goods and

services even if they are provided free or at minimum cost. The difference between the amount paid for a good or service, and the utility enjoyed is called the "consumer surplus" which can be measured by methods not in the scope of this study such as "compensating variation" and "equivalent variation". (ii) Initially it is assumed that, the marginal utility of income is the same for all individuals. This means that all individuals get the same amount of increased utility from one unit of additional income. According to Hufschmidt (1983), CBA is based on the concept of "Pareto improvement" in which a change is economically desirable if, in principle, the gainers can compensate the losers. Even if the actual compensation is not paid, the increase in net monetary benefits is desirable because of economic efficiency (Stiglitz 1986). When CBA is properly performed, benefits are defined in terms of their effects in contributing to the improvement of social welfare. Costs are defined in terms of their opportunity costs, which are benefits foregone by not using the resources in the best available alternative (*ibid.*).

Perhaps the single most widely used criterion in CBA is that which calculates "net present value" (NPV) of an enterprise; also known as "net present worth" (NPW) (Dixon *et al.* 1986). The NPV determines the present value of net benefits by discounting the streams of benefits (B) and costs (C) back to the beginning of the base year ($t=1$). Other used criteria include: internal rate of return (IRR), and benefit cost ratio (BCR) (Gittinger 1992). These criteria and several others have been widely covered by many authors hence will not be reviewed here. However for the purpose of this study, NPV will be used to compare benefits and costs basing on CBA. However, CBA does not optimize returns given some constraints. Hence optimizing techniques will still be used to optimize resource utilization in Mhonda village. Therefore, the household economic theory will be combined with mathematical programming based on constrained optimization models to pursue the objectives of this study.

3.0 METHODOLOGY AND DATA

3.1 Socio-economic survey

3.1.1 Description of the study area

Empirical data for the case study was obtained from Mhonda village ($6^{\circ} 08' S$ and $37^{\circ} 35' E$) in Turiani Division, Morogoro Region, Tanzania. The village is located on the windward eastern side of the Nguru mountains. It is only about 5 km north of Turiani (figure 3.1) and from Mhonda Mission there is a relatively easy access (1.5 hours walk) to the rain forest and to the forest reserve boundary.

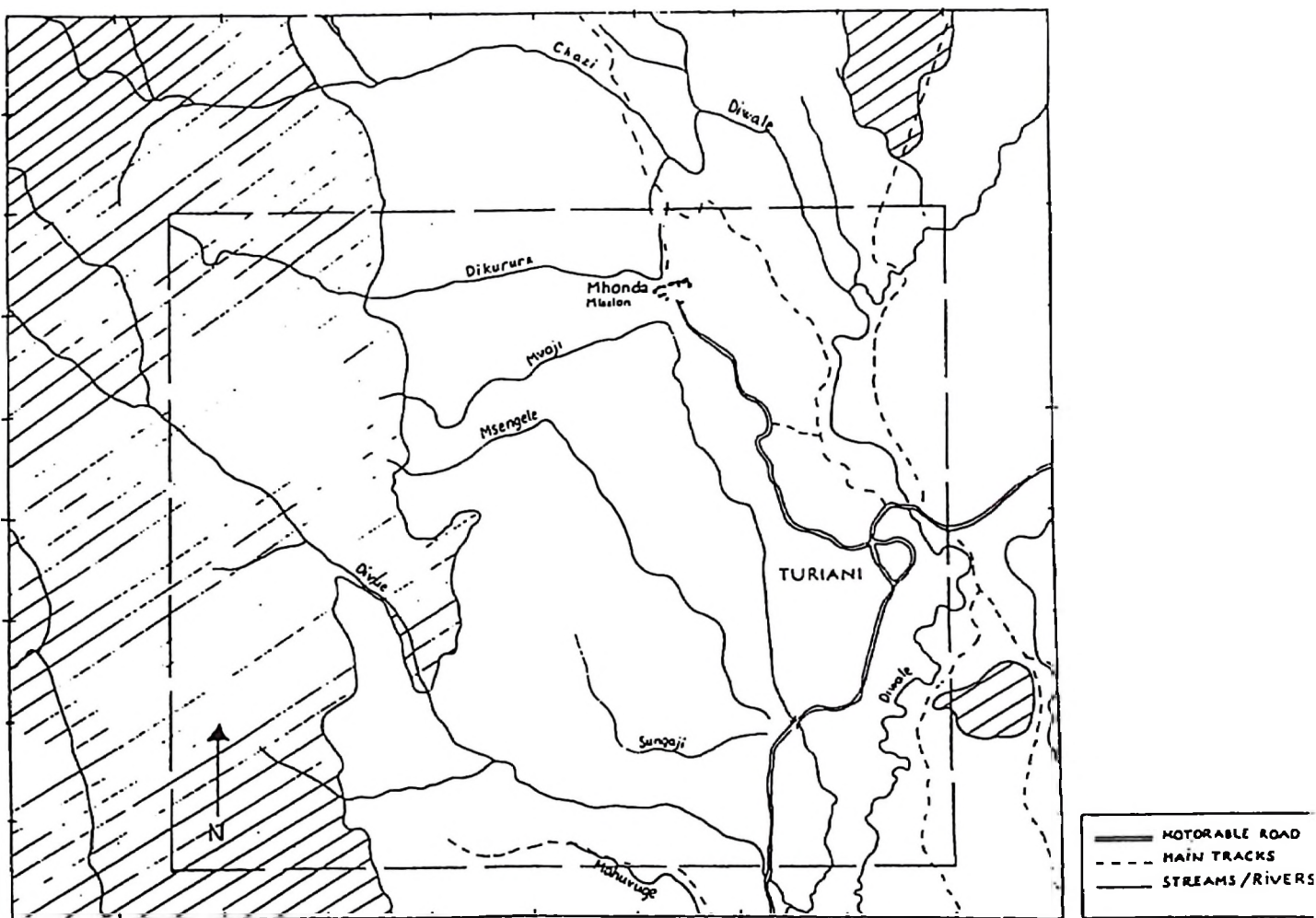

Figure 3.1. Location of the study area at scale of 1:50 000. The shaded area is the tropical rain forest on the 1972 topographic maps of the area. The boxed area refers to area focused for the study.

Mhonda village is located on an area with Precambrian crystalline rock composed of gneiss and granulite and to a lesser extent schists and granites (Poc's 1982, Bjørndalen 1991). Soils are mainly loamy entisols and ultisols with good drainage. The topography shows much variation. The climate is influenced by altitude, the north-east Trade Winds and the tropical rain forest ecosystem. Due to extensive cultivation in the lowlands, the lowland rain forests have been reduced and thus the submontane and montane rain forests usually between 700 and 1800 m.a.s.l. are predominant (Norris 1990, Poc's *et al.* 1990, Nsolomo & Chamshama 1990, Bjørndalen 1992). Rainfall is bimodal with a relatively short dry spell. It falls from October to December and from March to May when the longest and heaviest rainfall is experienced. The mean annual rainfall is 2000 mm. with much local variation. The annual mean temperature varies between 25°C on plains and 15°C at high elevation. December is often the hottest month (Poc's 1976).

The main ethnic group in Mhonda village are the Wanguu who are mixed with immigrants who have moved in the area in search of land, and employment. Family size is usually large and the majority of people are Catholics. The people have strong adherence to their culture and traditional beliefs and thus they still live in a very traditional style. Human population in the village has been growing due to high birth rate and influx of immigrants (Norris 1990, Nsolomo & Chamshama 1990). Mhonda Ward has experienced an average population growth rate of 3.7% per annum for the period 1978 through 1988 which is above the national average of 2.8% per annum (URT 1978 & 1991).

Land and property are invested patrilineally. Rain-fed agriculture is the main activity because almost all the people who have settled in the area practice some form of farming. The main agricultural practice is the basic slash and burn and the main cropping systems are monoculture cropping, multiple cropping and mixed cropping with some multi-purpose trees allowed to regenerate. Besides agriculture the other opportunities for generating income in the area include casual employment, small local enterprises, local crafts and local services. There is competition for land between forestry and agriculture such that cultivated fields extend up to the forest reserve border and some dwellings are located inside the forest reserve (Norris 1990). Forestry is basically conservation forestry aimed at meeting the needs of the local people within the overall broad objective of preserving the rain forest and its biodiversity.

A total of 61247 hectares of the tropical rain forests in the Nguru mountains are under government control as catchment forest reserves (Bjørndalen 1991). These are managed as Nguru South Range and Nguru North Range and they are recognized under the following Forest Reserves with area in parentheses: Nguru South Range in Morogoro Rural District: Nguru South (18800 ha); Kanga (6664 ha) and Mkindo (7541 ha). Nguru North Range in Handeni District: Kwediboma (285 ha); Mkongo (985 ha); North Nguru (14042 ha); Kilindi (4641 ha); Derema (3928 ha); Pumula (1062 ha); Mbwegere (368 ha) and Mkuli (2931 ha). The continuing growth in human population and economic demands have placed increasing pressure on these forests and the land around them (Mitzlaff 1991). In his GIS-based study, Norris (1990) notes that between 1949 and 1990, 0.5% per annum of the land area in the Nguru mountains was converted from "dense woody vegetation" (natural forest) to cultivated fields. This is a deforestation rate higher than the national average of 0.3% per annum (World Bank 1992). This threat to the

natural forest in the Nguru mountains need to be addressed. The specific socio-economic conditions of the village earmarked for this study are described in the next section.

3.1.2 Method of sampling

Mhonda village was purposely chosen for the case study. Why a case study approach was chosen is a subject of the next section. Only one village was chosen to be able to carry out the practical work and to get detailed and reliable data. For the same reason the household sample size has to be limited. A total of 77 households (14.1 percent) out of 546 households in the village were selected for the survey. The sampling intensity was considered satisfactory because according to Boyd *et al.* (1981) and to reduce cost, 5 percent of the population to be studied is considered statistically satisfactory. The chosen village, Mhonda, is situated in the densely populated eastern part of the Nguru mountains. This area receives rainfall up to 2000 mm per year and hence farming is the main occupation among the villagers. The village lies on the periphery of the tropical rain forest from which the villagers have for years derived local forest products. Population growth has increased the demand for various resources in the area and this has resulted into pressure on the environment.

The major concerns in the village involve food production, fuelwood for cooking and supplement income. Most of the fuelwood has been collected from the natural forest in the public land where supplies have dwindled and degradation both in the public woodlands and in the rain forest is considered a major concern. The food crops now grown in the village mainly for household consumption include some combination of grain, pulses, fruit and vegetable. Only few animals are sometimes raised. The current production in the village is limited by the available land, shortage of labour during certain seasons, lack of money to buy inputs and poor land use practices. Population growth, decline in crop production, low income, poor standard of living, resource depletion and ecological degradation and deforestation pressure on forest lands are seen as the major problems for the village which need to be addressed.

Therefore, this village represents an area where land use planning for sustainable management would be a suitable strategy to facilitate the optimal use of the scarce and dwindling resources to meet household needs while preventing ecological degradation. The efficient farm plans to be developed for the farm households in the case study village, could serve as a model for households in other villages in the Nguru mountains. However, this would require some modifications of the developed plans to cater for inter-village variation which according to studies in Tanzania (O'Kting'ati 1985) and in Zambia (Holden 1988 & 1991), it is smaller than intra-village variation in terms of household characteristics and availability of resources at village level. The choice of this village is also based on its geographical location with regard to its proximity to the tropical rainforest, population density and its pressure on natural resources, environmental and climatic factors, and the incidence of forest encroachment for agricultural expansion.

In this study the household was chosen as a sampling unit because this is a basic unit of production and consumption. The household is an important social unit because within it many

of the decisions concerning individual member's activities and their consumption (and thus their welfare) are made. Also the fact that the household is a collection of individuals with an identifiable location makes it a useful sample unit in survey work (World Bank 1990).

Thus the operational definition of the household as used in this study is as follows: The household is defined as a group of people who eat from a common pot, stay and work together and pool their resources. Dependent children who stay outside but usually come back for weekends and holidays were included because they belong to the same consumption unit. The absentees who pool their resources with the rest of the household or assist in kind through regular remittances were also included. Thus, this definition of the household hinges on five main features: sharing a dwelling house, cultivation of the same land, eating from the same pot, pooling of resources and recognition and acceptance of the authority of the head of the household (World Bank 1990, Holden 1988 & 1991).

Øyhus (1992) notes that family and household are both concepts that are used for the social unit found at the domestic level. Depending on how the two concepts are analytically defined both concepts may or may not cover the same social unit. The household is a bounded social unit possessing a variety of resources which may be used in different ways (Wallman 1979). The family on the other hand is a bounded social unit defined by marriage and descent (or marriage and kinship) and brings together a group of people related by agnatic and affinal bonds (Øyhus 1992). The two concepts cover two different but still overlapping and interdependent aspects of reality.

Stratified systematic sampling using the village register as a sampling frame was used to select the sample households. The sample was chosen by selecting a random number below 10 as a starting point then followed by every n^{th} household until the required sample size was achieved. The aim of stratification by altitude was to facilitate flexibility during the survey and also to increase the precision of estimates to be made from the sample. However, households were not divided into socio-economic classes such as progressive, average and marginal farmers which are based on overall economic performance in the village. Instead all farmers were treated as "average" farmers due to the fact that their economic performance is generally the same. Villager's persistent strong adherence to communal production imposed to them by the then socialist government may have contributed to the impoverishment evident on all farmers.

3.1.2.1 Why a Case Study Approach was chosen for this study

Casley and Lury (1982) define the term "case study" as " the detailed study of a small number of units, selected as representative of the group or groups relevant to the issue under consideration, but not necessarily representative of the statistical population as a whole. The method is indicated when it is necessary to probe deeply into the interrelationships between people and institutions; to establish and explain current attitudes and beliefs, and to show why certain behaviour occurs. Case studies are particularly appropriate when a high analytical content is required". In this study the issue being studied is seen as being particularly important hence needs to be treated in depth in order to understand complicated relationships which shape peasant farmers behaviour leading to degrading or clearing forests and woodlands in their vicinity. Thus

the use of the case study method is seen as relevant to achieve this aim. The case study approach is not so costly and also gives important information as starting point for possible bigger analysis. In this study discerning the interrelationships, causality and change is equally important as ensuring representativeness of the data collected. However, as is the case with all case studies, statistical inference is not the main concern of the study. Consequently following the rules of the case study approach, the study is intensive and time consuming thus resulting in only a very limited number of research units being investigated. However useful inferences and extrapolations can still be made from the case study results. According to Polak (1986) the inferential process by which the analyst may justifiably extrapolate from an individual case study to the social process in general turns exclusively on the theoretically necessary linkages among the features in the case study. The validity of the extrapolation depends not only on the typicality or representativeness of the case but upon the cogency of the theoretical reasoning (Mitchell 1983).

According to Casley and Lury (1981) the very strength of the case study method is that it can be used to reject existing generalizations. They point out that a number of case studies have certainly been important, for example, in undermining widely held views about the irrationality of peasant economic activities. They also point out one of its values as that it frequently shows the limitations of conventional wisdom, particularly incorrect stereotypes of rural life and activities which have often affected development policies in the past. A common incorrect stereotype is the assumption of homogeneity. Case studies may illustrate the importance of diversity of the system being studied and also of the strategies followed by farmers. Hence they provide important lessons for researchers who wish to develop "widely adaptable" technologies which this study also aims. The case study in this analysis includes data from a variety of sources as described in the next section.

3.1.3 Data acquisition

Data for the study were obtained from both primary and secondary sources. The primary data sources comprised of the following: The sample village, the sample households, the tropical rain forest, household farms and home gardens. The secondary data sources comprised of the following: literature survey, government records, aerial photographs and maps, personal communication (verbal sources), agencies with interests in the Nguru mountains, other institutions and services influencing production decision making at household level. The data were collected stepwise using a number of techniques in order to capture the relevant information (step-wise diagnostic approach). The main techniques used were:

- Interviews with farmers, village leaders, and the agricultural and forestry extension service officers. Questionnaires were used to guide the interviews with the farmers and village leaders. (the sample questionnaires are presented in Appendix 1).
- Observation of farms and the tropical rain forest (researcher's diary was used to record data during field observation)
- Continuous recording of household labour utilization, incomes and expenditure.
- Educated guesses and estimations for the missing data.

Questionnaire survey was administered by five enumerators guided by village leaders. All

enumerators were graduates of Sokoine University of Agriculture. On farm surveys, forest field visits, discussions, consultations and interviews were conducted by the researcher himself assisted by enumerators and village leaders. Establishment of rapport was easy to legitimize the research because the researcher had in the past visited the village while pursuing another but related research project. Frequent cross-checking of completed questionnaires by the researcher was practiced to ensure accuracy of the data collected by enumerators who had to stay permanently in the village during the study period. Actual field survey in Mhonda village took one year during the period July 1993 - June 1994 covering the whole production cycle. This was preceded by reconnaissance surveys conducted during the first half of 1992. The reconnaissance surveys helped to acquire preliminary data for the study and to establish rapport with the villagers before the actual survey was conducted. Informal meetings with villagers, giving them small gifts and living together with them during the study period increased the level of understanding and elicited villager's interest in the research.

Before conducting the actual on-farm surveys, the forestry and agricultural extension offices in the study area were consulted to obtain baseline forestry and agricultural data which later served to verify information collected from the farmers during the survey.

Field observations in the farms and forest entailed recording observable basic information and measurements. Data which could not be directly observed or measured was obtained from household members and this depended on their willingness and ability to remember (memorize) and give reliable information through responses to questions. In some cases proxy values were used as value tags. Data regarding encroachment in the forest reserve, protection and utilization of the tropical rain forest was obtained by direct observation, measurements taking and consulting with the forest offices (at Ward, Division, District, Regional and National level) responsible for management of the tropical rain forest.

Land use was evaluated by dividing the land according to crops or crop mixtures in the field. The relative profitability of the various crops that are grown on the land was used as a proxy value to measure the opportunity cost of the land. Land areas categorized by crop were measured using a tape measure. More accurate methods such as triangulation of fields or the use of plane tables and making draft maps of all fields was not feasible. Because of intercropping it was necessary to establish an effective area under each crop. This was done by calculating the average area ratio of intercropped or mixed crops. Crop yield recording depended on type of crop. Yield for grain and pulses was recorded in 100 kg bags while fruits and vegetables were recorded in 20 litre tins and converted to kg/ha. During recording of crop yields, allowance was made for crops consumed or sold in green condition. Labour data was collected by closely studying the activities of sample households during study months which were chosen such that they covered both the peak of farming activity (i.e. the rain season) and the time of the year when farming activity is at the minimum (i.e. the dry season). The aim was to get data for labour availability, labour demand and utilization and timing of operations over the year.

Contribution of each individual member to household labour was based on a scale designed by Due *et al.* (1984). The labour force was estimated as the labour available for farming activities. Household members employed outside the farm were recorded as consumers and only included

in the labour force if they participated in farm-work in addition to their employment. Output of labour was measured in terms of productivity for various products such as m³ of fuelwood from the tropical rain forest and kg of agricultural crops from the farm. The number of consumers in the household was estimated by correcting calorie requirement of household members based on FAO/WHO standards (1973). This was important in eliminating bias in the estimate of Consumer/Worker (C/W) ratios.

Income and expenditure data were estimated based on memory of household members during the continuous one year survey. There could be some underestimation since some expenditure may have been forgotten or strategically hidden, for example social expenditures on beer or income from selling things bit by bit as is often the practice with fruits and vegetables. Household members were asked to estimate their average consumption and expenditure on various commodities for a specified period deemed convenient. They were also asked to give information on savings and credit. However, some indication that households were able to make some small savings and lend relatives and friends could be gleaned from income expenditure data. These income expenditure data which are rather sensitive were collected after enough rapport was established with the villagers. This was important for ensuring reliability of the data. Moreover strategically timed crosschecking questions were used to reduce errors and inconsistencies. Data on local prices (farm-gate prices) for crops and commodity prices in the shops, local markets and in the village were collected by visiting these places and recording the data.

This study was conducted as a continuous one year survey which covered all seasons of the year.

The overall field research sequence of activities for this study was as follows:-

- obtain secondary data about the study site
- obtain permission (from District and Regional authorities) to conduct research in the selected study site
- meetings with Division, Ward and village leaders (i.e. local authorities) for introduction
- meetings at village level to collect relevant data for the entire village population
- recruitment and training of assistants for the household survey and testing questionnaires
- selection of a sample of 77 households for the survey,
- survey for the 77 households
- data compilation
- preliminary data analysis

The specific data collected can be more vividly seen in the interview schedule or questionnaire in appendix 1. However, the data collected can be grouped into the following categories:

- (a) Micro-level information focusing on: the physical and ecological environment, the socio-economic environment, land use and resources, and local level supporting services.
- (b) Macro-level information focusing on: policies, institutional support services and general macroeconomic data. In each category the data collected were as follows:

Physical and ecological data (biophysical data)

- agro-ecological zones
- topography, altitude and slope
- climate (rainfall, temperature, wind)
- growing seasons (months, number of days)
- soil conditions (type, fertility, nutrient loss per crop, physical and chemical characteristics of soil)
- hydrology (catchment forest, water table, stream flow, watersheds, irrigation water)
- vegetative cover (natural, cultivated, rain forest, buffer zones, biodiversity and its changes in harvested areas of the rain forest)
- ecological capabilities and limitations (e.g. perceived ecological risks).

Socio-economic data

- people (ethnic groups, household/family relations, customs and traditions, mode of living)
- population (total, density, growth, distribution by age and sex or gender)
- tenure system (rights to land, crops, trees, animals and other property)
- farm income (sources, levels)
- other income opportunities
- consumption patterns (food and nutrition, forest products, income expenditure)
- farm and forest-related production practices (inputs, outputs, levels)
- socio-economic capabilities and constraints (e.g. perceived socio economic risks, incentives and disincentives for local people to protect the rain forest, conflict between state and local interests, compensation for sacrifices made).
- time use

Land use data

- existing land use systems
- land availability
- land capability classes (land use options by suitability of crops)
- size of holdings (average, range, distribution)
- spatial arrangement of holdings (homestead, cropland, buffer zones, livestock and tree areas)
- crop production activities
- livestock production activities
- tree production activities (local products from the rain forest)
- interaction between crops, trees and livestock
(e.g. agroforestry, rain forest encroachment, grazing in the rain forest)
- land use causes of deforestation in both public lands and in the rain forest
- use of rain forest by zones
- institutional framework of land rights.

Resources and local level supporting system data

- labour (sources, skill, seasonality of availability in terms peaks and slacks)
- tools (type, acquisition, uses, useful life)
- other production inputs (fertilizer, manure, seeds, seedlings, chemicals)
- capital (sources, uses, access to creditors, interest on capital)
- local infrastructure (roads, schools, shops, markets, health centers, social amenities, transport means etc.)
- local organization.

Policies, institutional supporting services and general macroeconomic data

- marketing and price system
- credit facilities
- input supply channels and subsidies
- extension services
- bank services
- research facilities
- institutional infrastructure (e.g. electricity supply, distance to markets and road network)
- government policies (on supporting services and other external variables such as technology choice, land rights, moving people to low density areas).
- government failures perceived as risks to farming.
- exchange rates, interest rates and purchase power parity.
- remote sensed data
- nutritional data
- forest conservation

The data collected was prepared and processed before being coded by experienced research assistants from Sokoine University of Agriculture. Some data were summarized manually to single paper sheets while ensuring that the accuracy reflected the original meanings of the statements made by the respondents. From coding sheets data were transferred (punched) to data files at the Agricultural University of Norway. Data files were used for subsequent statistical analysis, micro-economic analysis and mathematical programming using several relevant commercial computer packages. Descriptive statistics of percentages and techniques of frequency counts, cross tabulations and correlation programs were generated in statistical analysis.

Micro-economic analysis was used to evaluate resources availability, productivity and utilization. The value of production inputs and outputs of the various crops and cropping systems under the existing land use practices in the village were computed. Gross margin analysis and benefit-cost analysis (based on neo-classical welfare theory) was used to evaluate profitability of these crops and cropping systems. Gross returns, gross margin and net returns to land, labour and capital expressed either in physical or economic terms were computed. Discounting was based on the market interest rate adjusted for inflation to get real interest rate.

The coefficients computed from the micro-economic analysis were used in mathematical

programming and optimization as described in section 3.2.

3.2 The mathematical programming model

3.2.1 Theory, hypothesis, basic assumptions and plan of the model

One basic management problem in this study is how to optimize the desired outputs from the land given the existing land use practices, resource constraints and peasant farmer's multiple objectives. The theoretical basis for optimal resource allocation and product mix in neoclassical economics is the theory of the firm. In this theory, marginal analysis is based on the concept of a production function. However, the direct practical use of the production function approach in determining optimal production decisions encounters a number of limitations. Because of these limitations, mathematical programming based on constrained optimization has been accorded wide applause in farm planning and management (Tibaijuka 1984, Mlambiti 1985, Solberg 1988, Kaoneka 1993).

In farm management one problem is to allocate resources in order to optimize returns. The allocation of scarce resources among competing ends is an economic problem whereas the optimization of returns is a mathematical programming problem which demands maximization or minimization of the value of some mathematical expression, subject to a number of restricting equalities or inequalities, all of which must be solved simultaneously for the values of the variables found in all expressions. Such variables are called "real activities" or decision variables (Dykstra 1984; Mlambiti 1985, Mansfield 1988). The algorithm used to solve a set of simultaneous equations is based on matrix algebra (Dykstra 1984). Linear programming which is a special mathematical model for constrained optimization has been widely used to handle optimization problems in farm management as in almost all other management sciences (Hillier & Liebermann 1986). However, in recent years with the improvement in computing facilities, powerful models based on non-linear programming have found application in farm planning. An example of such systems capable of handling non-linear functions is the "General Algebraic Modeling System" (GAMS) developed by the World Bank (Brooke, Kendrick & Meeraus 1992).

In a mathematical programming model there is already an implicit assumption of a production function which is homogeneous. There is no need to define a production function in such model. Therefore, in the mathematical programming model instead of defining the production function, what is defined are the different activities or different technical production processes and thereafter one works to arrive at an optimal combination of these production processes (i.e. to get an optimal technological arrangement) (Baumol 1977). This is an advantage over the neo-classical theory which assumes that the optimal technical production process is in a way already determined (*ibid.*). The mathematical programming approach as an analytical approach to resource allocation relates to the idea of constrained production possibilities due to restrictions on resource availability. Such constraints are a crucial feature of the economic situation of most peasant farmers, such as in Mhonda village, and the idea of identifying the most limiting resource has relevant application in the design of small farm economic plans and policies. Hillier & Liebermann (1986) define, in matrix notation, a general expression of the mathematical

programming model as follows:

$$\text{Maximize (or minimize) } z = fx \quad [3.1]$$

$$\text{subject to } g_1(x) = b_1 \quad [3.2]$$

.

.

.

$$g_m(x) = b_m \quad [3.3]$$

$$x_i \geq 0 \quad [3.4]$$

where,

f is the objective function to be maximized or minimized.

x_1, \dots, x_n are the decision variables or activities to be undertaken.

g_1, \dots, g_m are the constraints functions.

b_1, \dots, b_m are the constraints or resource levels and

$x_1, x_2, \dots, x_n \geq 0$

The model requires that each of the constraints functions values must satisfy a condition expressed by a mathematical inequality or an equality to the parameters b_1, \dots, b_m also called the Right Hand Side (RHS) (*ibid.*). Linear programming is a special case of this general model where all the functions are linear. Similarly, quadratic programming is a special case where all the functions in the model are quadratic or non linear etc. In this study the problem is related to the allocation of land and other resources among competing ends in order to maximize net cash income, minimize income variation (risk) and labour use variation while meeting subsistence requirements. This kind of problem lends itself to the use of mathematical programming to develop a model that can serve as a land use planning tool in to foster efficient resource use for development of peasants farmers. Such a model may enable farmers and planners to predict the scale and composition of agricultural output and incomes as constraints are relaxed and new situations (policies) arise. It can be hypothesized that having a model that can assist farmers and planners to arrive at optimal decisions in allocating scarce resources can contribute greatly to making land use planning and resource use a more meaningful exercise. Even if resources are by chance efficiently allocated, it is still useful and justifiable to develop a planning tool to guide farmer's and planner's intuition.

Therefore, a multi-objective mathematical programming model using compromise programming (CP) was developed to measure the productivity and efficiency in agriculture resource use of peasant households in Mhonda village (Appendix 6). This model was applied to compromise simultaneously several objectives using vector optimization compromise programming subject to a number of constraints. The vector of three objectives includes maximization of net cash income from crops during a given agricultural year, minimization of risk and minimization of labour use variation over the year. The aim was to fulfill peasant needs while compromising the other production objectives. Based on the farmer's responses, weights given for the three objectives were: 1 each for maximization of income and minimization of risk and 0.1 for minimization of labour use variation. The overriding assumption used in this study was that the peasant farmers aim at maximizing income, minimizing risks in farming and minimizing labour use variation over

the year. Other assumptions were as follows: (a) It was assumed that whenever opportunities were available, a farmer may borrow working capital from money lending institutions at an annual interest rate of 31 percent with an inflation of 25 percent per annum as at June 1994 (NBC 1993, Business Times Magazine 1994). The real interest rate used in the model is 6 percent per annum. Due to the fragmentary nature of capital markets, peasants in Mhonda village may sometimes obtain credit locally from local money lenders at rates of interest which reflect the individual circumstances of each transaction, not a market clearing condition. The working capital was taken to consist of cash used for purchase of seeds, tools, chemicals (excluding fertilizer as it was used as a separate activity in the market) and other expenses. Some working capital can be raised from own savings and remittances. (b) Free-hold markets for land does not exist and hence non-market rights of access or non-price forms of tenancy are predominant over non-existent open market transactions in land. Consequently, land tenure system in the village involves no land buying or selling activities. (c) There is very little labour hiring in activities even in peak months to the extent that it can be ignored in this analysis. The main reason is that peasants have no cash for hiring in labour and hence they rely solely on family labour, labour of close relatives and sometimes practice labour reciprocity (i.e work parties). "Reciprocity" refers to exchanges that are culturally defined, non-replicable between one event and the next, and involve unlike goods and services (Ellis 1987). The reciprocal and sharing aspects are common in peasant societies like in Mhonda village such that their economies are sometimes referred to as "moral economies" or "economies of affection" (Hydén 1980). However, labour hiring out for off-farm activities is practiced in the bid to earn extra income for buying market goods. (d) Farming technology is low and assumed to remain unchanged at least for the period being analyzed. This is assumed so because of peasants tendency to slowly adopt new technology or to stick to old traditional systems of doing things. Thus, under this assumption, farm resources are thought to be fixed in both supply and use. (e) Consumption transfer activities (such as food remittances to relatives) are included in household crop consumption activities. (f) Available labour for farming activities in each calendar month (average net days available for farm work) is assumed to exclude days for off-farm activities. Days for off-farm activities include the following: (i) days for cultural ceremonies and other local festivals (ii) days for national (state) festivals such as the Independence day, Zanzibar Revolution day, Worker's day, Peasant's day and the Union day. (iii) Religious holidays (Easter, Easter monday, Christmas, Boxing day, New year day, Idd el Haj, Idd el Fitr, and Maulid) (iv) Prayer days (Sundays only because 99% of the people in Mhonda village are Christians). (v) Rainy days (i.e. those days in which persistently heavy rain prevents people from going out into field for farm-work. In this study sick-days and rest days other than holidays are included in this category.

The model included all the important activities mainly crop production, fertilizer and other input purchase and consumption. The maximization of total net income uses farmer's gross margins (gm_i) as coefficients in the objective function. In this case gross margins are the decision variables or production real activities. Other activities included in the objective function include purchase activities for the mineral fertilizers nitrogen and phosphorus. For these, their market prices served as coefficients. Another activity included in this model is working capital borrowing activity at the prevailing market rate of interest. The coefficients for fertilizer purchase and working capital borrowing embodied both "principal" and "interest" for the borrowed money.

In food allocation, the household's minimum subsistence requirement was specified for each crop. This was based on farmer's behaviour that they aim first at meeting household needs before they decide to commit for sale that part of produce above subsistence needs in order to purchase market goods. The minimum food requirement per person as recommended by FAO/World Bank (1973) and Latham (1979) was also considered. In this model sale activities were exogenously incorporated in the gross margin-based coefficients in the objective function.

In the analysis with the model, the base run involved a static model whose aim was to maximize income from a household farm while meeting consumption needs, to minimize risk and to minimize labour use variation under resource constraints. By static is meant that, it does not include changes in yields over time when fields are put under various crops for several seasons. Also does not include changes in yields over time due to increase in land area as a result of land clearing. Population was then introduced in the model as a dynamic factor in order to determine the effect of population growth on per capita food consumption, per capita income, per capita land demand and deforestation. The purpose of this analysis was to try to show the level of sustainability of the existing farming systems under the conditions of population growth. Moreover to elucidate the pressure on forest lands caused by the growth of population. Since there is always a possibility for change on the values of some key variables (on account of risk), a sensitivity analysis was done first on farm-gate (producer) price changes with the aim of exploring the consequences of a particular pricing policy and how the peasant household responds to such price changes. Sensitivity analysis was also carried out to determine the effect of changes in the land area constraint particularly the effect of new land acquisition through forest clearing in encroached areas. The effect of changes of total working capital on the use of resources and deforestation was also analyzed. This was felt important since working capital is among the most important limiting factors in peasant agriculture. The household farm data used in this study is a result of field surveys conducted in Mhonda village and supplemented with data from other relevant sources.

3.2.2 Model description and data

3.2.2.1 Definition of cropping systems and crops grown in Mhonda village

The cropping systems practiced in Mhonda village and used to calibrate the model can be categorized into 3 main groups. These are monoculture cropping system, mixed cropping system (intercropping) and multiple cropping system. In this study, these are defined as follows: (a) Monoculture cropping system involves growing a single crop on a particular piece of land. This is practiced for maize, beans, cassava, rice, sorghum and vegetables. (b) Mixed cropping (intercropping) system which involves growing together (intermingling) of a variety of crops on the same piece of land. It is practiced by mixing maize and beans; maize and sorghum; cassava and beans; maize, beans, cassava and sorghum; banana and cassava; fruit trees and cassava and a mixture of minor crops such as peas and groundnuts (Appendix 2). (c) Multiple cropping system in which two or more crops are grown consecutively (i.e. one after another has matured) on the same plot of land. It is practiced by growing maize and beans followed by beans during long rains. This system is also referred to as rotation of crops.

3.2.2.2 Definition of the decision variables for the model

Based on these cropping systems and crops grown, the decision variables for the model were defined. For convenience of specifying the model, crops were classified into 18 crop production activities which are defined in section 3.2.2.3.

3.2.2.3 Crop production activities

Columns 1-18 in the input-output matrix represent crop production activities under the earlier defined cropping systems. These are denoted by X_i , where,

X_i = hectares of land allocated to crop i , where,

$i = 1, 2, \dots, 18$, representing the following:

- 1 = short rain maize grown in upland (MSRU) under monoculture cropping system
- 2 = long rain maize grown in upland (MLRU) under monoculture cropping system
- 3 = short rain beans grown in upland (BSRU) under monoculture cropping system
- 4 = long rain beans grown in upland (BLRU) under monoculture cropping system
- 5 = cassava (C) grown in upland under monoculture cropping system
- 6 = long rain rice grown in lowland under monoculture cropping system
- 7 = long rain sorghum (S) grown in upland under monoculture cropping system
- 8 = long rain vegetables (V) grown in lowland under monoculture cropping system
- 9 = short rain and beans (B) grown in upland under mixed cropping system
- 10 = long rain maize and beans (M/B) grown in upland under mixed cropping system
- 11 = long rain maize and sorghum (M/S) grown in upland under mixed cropping system
- 12 = long rain cassava and beans (C/B) grown in upland under mixed cropping system
- 13 = long rain maize, beans, cassava and sorghum (M/B/C/S) grown in upland under mixed cropping system
- 14 = Banana and cassava (B/C) grown in upland under mixed cropping system
- 15 = Fruit trees and cassava (FR/C) grown in upland under mixed cropping system
- 16 = minor crops (Mc) such as peas and groundnuts grown in upland under mixed cropping system
- 17 = long rain maize and beans (M/B) grown in lowland under multiple cropping system
- 18 = long rain beans (B) grown in lowland under multiple cropping system

3.2.2.4 Purchase activities

Columns 19-21 in the input-output matrix represent input purchase activities for fertilizer and working capital. The symbols used to represent purchase activities are defined as follows:

X_n = kilogrammes of nitrogen fertilizer purchased per year

X_p = kilogrammes of phosphorus fertilizer purchased per year

X_k = cash (T.Shs.) borrowed as working capital per year

3.2.2.5 New land clearing activities

Columns 22-24 in the input-output matrix represent new land clearing activities for farmland

expansion. The symbols used are defined as follows:

LR = new land cleared during long rains

SR = new land cleared during short rains

VL = New land cleared for growing vegetables.

3.2.2.6 Crop consumption activities

Columns 25-33 in the input-output matrix represent crop consumption activities by households. The symbols used to represent crop consumption activities are defined as follows:

C_i = kg of crop i consumed by the household per year,

where, $i = 1, 2, \dots, 9$ representing the following:

1 = kg of maize consumed by the household per year

2 = kg of beans consumed by the household per year

3 = kg of cassava consumed by the household per year

4 = kg of rice consumed by the household per year

5 = kg of sorghum consumed by household per year

6 = kg of vegetables consumed by household per year

7 = kg of banana consumed by household per year

8 = kg fruit consumed by household per year

9 = kg of minor crops consumed by household per year

3.2.2.7 Right Hand Side (RHS) values for the constraints

In an input-output formulation, the RHS values for the constraints must be specified in order to make the formulation complete. Thus the symbols used to represent the values of the RHS for each constraint (row) are defined as follows:

A_{lr} = ha of land available for growing crops during long rain (lr) season ("masika").

A_{sr} = ha of land available for growing crops during short rain (sr) season ("vuli").

A_{up} = ha of land available for growing crops in upland

A_{ll} = ha of land available for growing crops in lowland

A_{ca} = ha of land available for growing cassava

A_{ba} = ha of land available for growing banana

A_{fr} = ha of land available for growing fruits

L_t = adult equivalent mandays of available labour during month, t , where, $t = 1, 2, \dots, 12$
and 1 = January, 2 = February, ..., 12 = December.

M = tonnes of farmyard manure available for a household in a year.

K = total working capital (T.Shs.) available for farming activities (i.e. for buying fertilizer, chemicals and tools).

F_i = kg of crop i required to meet minimum household food (nutritional) requirement.

3.2.2.8 Technical input-output coefficients for the mathematical model

There are a number of technical coefficients associated with the real activities (decision variables) in the model. The symbols used to represent these technical coefficients are defined as follows:

l_{ti} = adult equivalent mandays of household labour required in month, t , per hectare of crop i .

n_i = kg of nitrogen fertilizer required per hectare of crop i

p_i = kg of phosphorus fertilizer required per hectare of crop i .

k_i = cash money (T.Shs.) of working capital required per hectare of crop i .

m_i = tonnes of farmyard manure required per hectare of crop i .

q_i = kg of crop i produced per hectare

f_p = market price of phosphorus fertilizer, T.Shs.kg⁻¹

f_n = market price of nitrogen fertilizer, T.Shs. kg⁻¹

f_i = farmgate price for crop i , T.Shs.kg⁻¹

g_{mi} = gross margin at farmgate prices for crop i , T.Shs.kg⁻¹

c_i = kg of crop i , consumed per household per year.

r = real interest rate per annum, %.

3.2.2.9 Generalized detached coefficient matrix for the model

Based on the definitions of decision variables, technical coefficients and RHS values, table 3.1 presents the generalized detached coefficient matrix for the model. This matrix includes objective functions and constraints which are described in the sections which follow.

3.2.2.10 Definition of objective functions

The objective function for maximization of income aims to find the optimal mix, consisting of 18 categories of crops, that produce maximum total net income subject to land, labour, capital, subsistence and nutritional requirements. Based on these facts, the objective function for the deterministic variable, income, is as follows:

$$\text{Maximize } Z = \sum_{i=1}^{18} gm_i X_i - f_p (1+r) X_p - f_n (1+r) X_n - (1+r) X_k \quad [3.5]$$

The definition of variables remain as defined in section 3.2.2. The stochastic variables which formed the other two objective functions in the compromise programming model are mainly risk and labour use variation. These were used in a quadratic form (Equation [2.14] in section 2.1.12.3). For the objective function involving minimization of risk, the risk elements considered are those which have a bearing on net cash income namely crop yield and price (marginal return). In agricultural literature, farm prices and yields have been major sources of risk that are manifest in the objective function as variation in gross margins for individual crop and livestock enterprises (Boisvert & McCarl 1990). The household's annual actual gross income over a five year period (1989-1994) was used to calculate income variance and covariances (Appendix 3) used as input in the model. It would have been more desirable to take more years for capturing

Table 3.1 Generalized format of the detached coefficient matrix for the model

Row identity	Decision variables					Sign	RHS
	Crop production	Input purchase			Household consumption		
		Phosphorus	Nitrogen	Working capital			
	X_y	X_x	X_p	X_k	C_i		
Objective function ¹ :							
Income (T.Shs.)	$+gm_i$	$-f_x(1+r)$	$-f_p(1+r)$	$-(1+r)$	0	Max	I
Land area (ha):							
Long rains	$+l$	0	0	0	0	\leq	A_u
Short rains						\leq	A_w
Household labour(ME-mandays)							
January							
.							
.	$+l_d$	0	0	0	0	\leq	L_t
December							
Fertilizer nutrients (kg):							
Nitrogen	$+n_i$	-1	0	0	0	\leq	0
Phosphorus	$+p_i$	0	-1	0	0	\leq	0
Farmyard manure (t):	$+m_i$	0	0	0	0	\leq	M
Working capital (T.Shs.)	$+k_i$	0	0	0	0	\leq	0
Working capital limit (T.Shs.)	0	$+f_x$	$+f_p$	+1	0	\leq	K
Food allocation (kg):							
Maize							
Beans							
Cassava							
Rice							
Sorghum	$-q_i$	0	0	0	c_i	\leq	0
Vegetables							
Banana							
Fruit							
Minor crops							
Land area (ha):							
Upland	$+l$	0	0	0	0	\leq	A_u
Lowland						\leq	A_w

Footnote: 1 Minimization of risk and labour use variation objectives were used in a quadratic form

the gross revenue variations, but experience in Tanzania shows that a five-year period adequately represents the variation in yields and crop (product) prices (Sankhayan & Øygard 1993, Kaoneka 1993). Moreover if it were not for the non-availability of data on input costs relating to the previous years, the use of net returns (gross margins) as risk variations would have certainly been a preferred alternative to gross returns. However it is believed that such a measure (i.e. gross returns) would adequately capture the main components of risk due to variations in product prices and yields (Sankhayan & Øygard 1993). For the objective function involving minimization of labour use variation the optimization was based on labour use over twelve months of the year. The objective function aimed at minimization of the standard deviation of labour use. The household's actual annual labour use data by months was used in the calculations of variances and covariances used as input in the model (Appendix 4).

3.2.2.11 Definition of constraints for the models

Labour constraint

From table 4.13, the peak months in terms of labour requirements are January, February, March, April, May, September, November and December. These are the months when there is labour deficiency (i.e. labour availability falls short of labour requirements). It is during these months that labour is limiting and hence are used as labour constraints (i.e. L_t is such that $t = 1, 2, \dots, 8$). On the basis of the above information, the labour constraints can be expressed as:

$$\sum_{t=1}^8 \sum_{i=1}^{18} I_{t,i} X_i \leq L_t \quad [3.6]$$

The definitions of variables remain as in section 3.2.2.

Fertilizer requirements

Numerous experiments have shown that in tropical soils which have been cropped 2 or 3 years or more, food and cash crops grown by small farmers readily respond to applications of nitrogen and phosphate, and less frequently to potash (Webster & Wilson 1980, Mowo *et al.* 1993). Despite this evidence, relatively little fertilizer is currently used in rural Tanzania because most small farmers cannot find cash to buy it (Mowo *et al.* 1993). Nevertheless, fertilizer usage is growing slowly and is expected to continue to do so, aided by growing capital to farmers and increasing local manufacture of nitrogenous fertilizers, government subsidy and greater use of higher-yielding crop varieties that respond well to fertilizer (Gillard-Byers 1984).

Different fertilizer types react differently when applied to soil and plants do not need all nutrients at the same time in the same quantity.

Nitrogen (N) is needed most by short duration crops during the major growth periods whereas phosphorus (P) is mostly needed in the early growth stages. Moreover, N is generally required over a longer period than P and for these reasons, N is often given in split applications and P in a single dose at planting (Mowo *et al.* 1993). It is extremely important that such fertilizers are used as economically as possible and this largely depends on selecting the right kind of fertilizer and the optimum rate, time and method of application in relation to the needs of the growing crop, the nutrient status of the soil and the effects of the weather, especially rainfall (Webster & Wilson 1980). All this boils down to "efficient" use of fertilizers which means the supply of the proper amount of plant nutrients at the correct time, in a plant available form of nutrient, while at the same time avoiding losses as much as possible (Mowo *et al.* 1993). In the models, nitrogen and phosphorus are the limiting mineral fertilizers and their availability levels are used as constraints as expressed in the following sections.

Nitrogen nutrient constraint

Nitrogen, a macronutrient is applied by top-dressing to crops as sulphate of ammonia (SA) available to crops in ammonium or nitrate forms. Its acidifying properties make it unsuitable in acid soils (Mowo *et al.* 1993). The level of application depends on each crop requirement. SA contains 21 percent nitrogen by weight and the present levels of application to crops which need it in Mhonda village are as follows: 22.5 kg ha^{-1} for maize, 100 kg ha^{-1} for rice, 20 kg ha^{-1} for sorghum, and 150 kg ha^{-1} for vegetables. Based on these facts, the nitrogen nutrient constraint can be written but with the condition that the amount of N fertilizer purchased must not be less than the amount required by the allocated cropping systems. This is as follows:

$$\sum_{i=1}^{18} n_i X_i - X_n \leq 0 \quad [3.7]$$

The symbols used remain as defined in section 3.2.2.

Phosphorus nutrient constraint

Most of the phosphorus is taken up by crops in the form of $H_2PO_4^-$ ion or HPO_4^{2-} ion and compared with nitrogen, the amount required by crops is relatively small (Kowal & Kassum 1978). Phosphorus is often applied at planting as triple superphosphate (45% P_2O_5). The present levels of application for crops which need it in Mhonda village are as follows: 15 kg ha^{-1} for maize, 20 kg ha^{-1} for beans, 50 kg ha^{-1} for rice, 20 kg ha^{-1} for sorghum, 50 kg ha^{-1} for vegetables. As for nitrogen, the amount of phosphorus fertilizer purchased must not be less than the amount required by the allocated cropping systems. Thus with these facts, the phosphorus constraint can be written as follows:

$$\sum_{i=1}^{18} P_i X_i - X_p \leq 0 \quad [2.33]$$

The symbols used remain as defined in section 3.2.2.

Manure requirement constraint

Farmyard manure consisting of a rotted mixture of the excreta of animals and the straw provided for their bedding is a traditional most useful technique for land fertility maintenance (Webster & Wilson 1980). The manure is customarily available from herds and flocks of pastoralist Maasai communities living in the dry western slopes of the Nguru mountains hence called "kraal" manure, "boma" manure or just cattle manure. Only a small proportion is obtained from within the village. It is often of poor quality since it consists of the weathered excreta of animals kept in uncovered pens, usually without bedding, and is commonly mixed with a considerable amount of soil. Farmers believe that annual crops respond well to applications of farmyard manure applied as dressings after planting or mixed with soil before planting to maintain crop yields under continuous cultivation provided a suitable rotation is followed.

The annual rate of application of farmyard manure in Mhonda village is 2 tonnes per hectare for beans under monocropping, 2 tons per hectare for the maize/beans mixture, and 2 tons per hectare for the fruit trees/cassava mixture. 3 tonnes per hectare for banana/maize mixture, 3 tons per hectare for the maize/beans/cassava/sorghum mixture and maize/beans mixture under multiple cropping and 5 tonnes per hectare for vegetables. Heavier applications or dressings would be preferred but the manure is not easily available in abundance due to small number of animals in Mhonda village. Thus 5 tonnes per hectare per year is also considered the upper limit of farmyard manure a household can access in a year. Other limitations to intensive use of farmyard manure in the village include lack of wheeled transport for manure to fields, and lack of tradition among some farmers to make farmyard manure and use it to the fields.

Thus the manure requirement constraint can be expressed as follows:

$$\sum_{i=1}^{18} M_i X_i \leq 5 \quad [3.8]$$

The definition of variables remain as in section 3.2.2.

This constraint implies that the total amount of farmyard manure applied cannot exceed the maximum quantity accessible to the farm household in a year.

Working capital constraint

In this study, working capital refers to the cash allocated by the household for the purchase of seeds, hand tools and chemicals. Working capital varies with farming system and crop type because of differences in requirement for seeds, hand-tools and chemicals between the crop types and farming systems. A borrowing activity is included such that a farmer will borrow capital at the existing lending rate of interest as long as it is profitable and opportunities are available. Based on these facts, the working capital constraint can be expressed as follows:

$$\sum_{i=1}^{18} K_i X_i - X_k \leq 0 \quad [3.9]$$

The condition of this constraint is that the amount of working capital items purchased cannot exceed the total sum of cash allocated as working capital. The symbols used remain as defined

in section 3.2.2.

Capital limit constraint

The aim of this constraint is to specify the ceiling for use of borrowed capital. Consequently the sum of the value of working capital for other inputs and cost of mineral fertilizers cannot exceed the total available borrowed capital such that: (capital limit = value of working capital for inputs + cost of fertilizers).

Therefore, the capital limit constraint can be expressed as follows:

$$X_p + X_n + X_k \leq K \quad [3.10]$$

The symbols used remain as defined in section 3.2.2.

Food allocation constraints

Food requirement differs greatly among different categories of people depending on age, body weight, level of activity, climate and sex; and for women, pregnancy or lactating condition (Latham 1979). Based on these factors, the different consumption categories that may be identified are adult men and women who may be active, very active or sedentary. Others are pregnant women, lactating women and children.

According to FAO/WHO (1973) and Latham (1979) very active people need more food than sedentary ones. Similarly, nutritional needs of a woman during pregnancy (and lactation) are greater than at other times in her life because at this time she is building in her own body the tissues and organs of a new human being. Also women gain weight during pregnancy hence they need more energy because a heavier person needs more energy to perform the same amount of physical work as a lighter person. In much of Africa and Tanzania pregnant women, even during their last few months of pregnancy, remain active (Latham 1979). The basal metabolic rate usually increases during pregnancy which again raises energy requirements (*ibid*). Thus most women in Tanzania and Africa need more energy when they are pregnant.

Lactating women, in addition to the normal food requirements, they need extra food to replace both the blood lost during delivery and nutrients provided as milk for their infants. Breast feeding in Africa commonly continues for over a year, and not infrequent for two years. Thus, in young children, pregnant and lactating women as well as very active people, energy requirements are relatively high and in consequence a large quantity of the staple carbohydrate food has to be eaten to satisfy these needs. Apart from exceptional years and at the end of the agricultural season, people in many parts of Tanzania have something to eat, enough to fill their stomachs and assuage hunger. This food is usually composed of predominantly carbohydrate foods. Thus ideally this food must be supplemented with other foodstuffs that provide necessary nutrients like vitamins and proteins. Such foods are like fresh fruits, vegetables, legumes (pulses) and meat.

The purpose of the food allocation constraint is to restrict crop production activities such that output allocated for consumption meets the recommended minimum nutrient requirement of the different consumption categories in the household as mentioned above. The food allocation

constraints can be specified for each crop grown in Mhonda village as follows:

Food allocation constraint for maize

According to FAO/WHO (1973) standards, one consumption unit requires 2600 kcal per day and 60 g protein per day. A consumption unit is computed using the standard WHO weights of 0.5 for children below 11 years, 0.75 for children below 16 years and 1.0 for all other age categories. On the basis of this, the average number of consumption units in a typical household in Mhonda village is calculated as follows: The composition of an average household in the village is 7 people of which 2 are full-time working adults over 18 years, 2 are between 12- 17 years and 3 are between 8-11 years.

Thus based on FAO/WHO standard weights, the average household has 5.0 consumption units (i.e. $(2 \times 1) + (2 \times 0.75) + (3 \times 0.5) = 5.0$). On the basis of the mean consumption unit size of 5.0 per household, the total annual caloric requirement for the average household is:

$(2600 \text{ kcal/day}) \times (5 \text{ consumption units/household}) \times (365 \text{ days/year}) = 4\,745\,000 \text{ kcal/year}$.

Similarly, the annual protein requirement for the household is: $(60 \text{ g protein/day}) \times 5 \text{ consumption units/household} \times (365 \text{ days/year}) = 109\,500 \text{ g protein/year}$. Survey results in Mhonda village show that maize provide about 30 percent of the total household caloric requirements. From a comprehensive list of nutritional content of typical African foods as provided by Latham (1979), the caloric content of a maize meal (whole grain) is 3590 kcal/kg. Thus the quantity of maize set aside by a household for annual subsistence consumption is calculated as follows:

$$\frac{0.3 \times 4\,745\,000 \text{ kcal/year}}{3590 \text{ kcal/kg}} = 397 \text{ kg/year.}$$

Therefore the output allocation constraint for maize can be expressed as

$$397 - \sum_{i=1}^{19} \alpha_i X_i \leq 0 \quad [3.11]$$

This constraint means that maize crop produced in all cropping systems must at least meet subsistence requirements of the household.

Food allocation constraint for beans

Using the mean consumption unit of 5 per household, and the FAO/WHO standard of 60 g protein per day for one consumption unit, the total annual protein requirement for the average household is calculated as follows: $(60 \text{ g protein/day}) \times (5 \text{ consumption units/household}) \times (365 \text{ days/year}) = 109\,500 \text{ g protein/year}$. Survey results show that beans constitute the main source of protein in Mhonda village and provide about 50 percent of total household protein requirements. Based on Latham (1979), the protein content of a bean meal (whole seed) is 217 g protein/kg. Thus the quantity of beans set aside by a household for annual subsistence

consumption is calculated as follows:

$$\frac{0.5 \times 109\,500 \text{ g protein/year}}{217 \text{ g protein/kg}} = 253 \text{ kg/year.}$$

Thus the output allocation constraint for beans can be written as:

$$253 - \sum_{i=1}^{18} \alpha_i X_i \leq 0 \quad [3.12]$$

This constraint means that the bean crop produced in all cropping systems must at least meet subsistence requirements of the household.

Food allocation constraint for cassava

The total annual household caloric requirements using FAO/WHO standards and Latham (1979) for 5 consumption units household is 4 745 000 kcal/year. Survey results in Mhonda village show that during the "good" harvest years, cassava is usually consumed in complementarity with maize as a source of calories. However, the quantity consumed rises sharply during "bad" harvest years or during outbreaks of famine. During such years cassava serves as a famine crop to cushion crop failures. Nevertheless, the year in which this study was conducted was not a "bad" harvest year. Consequently, cassava consumption remained at about 50 percent of the total household caloric requirement in Mhonda village. Based on Latham (1979) the caloric content of cassava meal (flour) is 3630 kcal/kg. Thus the quantity of cassava set aside by a household for annual subsistence during a "good" harvest year is calculated as:

$$\frac{0.5 \times 4\,745\,000 \text{ kcal/year}}{3630 \text{ kcal/kg}} = 654 \text{ kg/year}$$

Thus the output allocation constraint for cassava can be expressed as follows:

$$654 - \sum_{i=1}^{18} \alpha_i X_i \leq 0 \quad [3.13]$$

This constraint implies that cassava produced by all cropping systems must at least meet subsistence needs of the household.

Food allocation constraint for rice

Based on FAO/WHO standards (1973) and Latham (1979), the caloric content of rice meal is 3640 kcal/kg. Survey results in Mhonda village show that rice is among the favourite foodstuffs but due to inadequate production it contributes only about 10 percent of total household energy requirements. Thus the quantity of rice required to meet household annual subsistence needs is

$$\frac{0.1 \times 4\,745\,000 \text{ kcal/year}}{3640 \text{ kcal/kg}} = 131 \text{ kg/year}$$

Thus the food allocation constraint for rice can be expressed as

$$131 - \sum_{i=1}^{18} q_i x_i \leq 0 \quad [3.14]$$

This implies that rice produced by all cropping systems must at least meet subsistence requirements of the household.

Food allocation constraint for sorghum

Based on FAO/WHO standards (1973) and Latham (1979) the caloric content of sorghum is 3470 kcal/kg. From survey results in Mhonda village, sorghum contributes about 5 percent of the total household energy requirements. Thus the quantity of sorghum required to meet household subsistence needs is

$$\frac{0.05 \times 4\,745\,000 \text{ kcal/year}}{3470 \text{ kcal/kg}} = 69 \text{ kg/year}$$

Thus the food allocation constraint for sorghum can be expressed as

$$69 - \sum_{i=1}^{18} q_i x_i \leq 0 \quad [3.15]$$

This means that sorghum produced must at least meet household subsistence requirements.

Food allocation constraint for vegetables

Although vegetables are in most cases used as a source of vitamins they also contain proteins and other nutrients (Latham 1979). Thus in formulating this constraint vegetables were treated as a source of proteins due to the nature in which they are consumed as main relishes for maize, cassava or rice meal. Also the fact that vitamins are measured in micro units. According to Latham (1979) and FAO/WHO (1973), vegetables contain about 25 g proteins/kg. Survey results in Mhonda village show that vegetables consumed as relishes and spices constitute about 13 percent of total household protein requirements. Thus the annual quantity of vegetables required to meet household subsistence requirements is

$$\frac{0.13 \times 109\,500 \text{ g protein/year}}{25 \text{ g protein-vitamins/kg}} = 600 \text{ kg/year}$$

Thus the food allocation constraint for vegetables can be expressed as

$$600 - \sum_{i=1}^{18} q_i x_i \leq 0 \quad [3.16]$$

This means that vegetables produced by all cropping systems must at least meet household

subsistence requirements.

Food allocation constraint for banana

According to Latham (1979) and FAO/WHO (1973) standards, the caloric content of banana meal (boiled) is 880 kcal/kg. Survey results in Mhonda village show that banana contribute 2 percent of total household energy needs. Thus the quantity of banana set aside for household annual subsistence is

$$\frac{0.02 \times 4\,745\,000 \text{ kcal/year}}{880 \text{ kcal/kg}} = 108 \text{ kg/year}$$

Thus the food allocation constraint for banana can be expressed as

$$108 - \sum_{i=1}^{18} a_i x_i \leq 0 \quad [3.17]$$

This means that banana produced must at least meet household subsistence requirements.

Food allocation constraint for fruits

According to FAO/WHO standards (1973) and Latham (1979) standards the caloric content of fruit is 2100 kcal/kg. Survey results in Mhonda village show that fruits contribute about "percent of total household caloric requirements. Thus the quantity of fruit required to meet annual household subsistence requirements is

$$\frac{0.02 \times 4\,745\,000 \text{ kcal/year}}{2100 \text{ kcal/kg}} = 46 \text{ kg/year}$$

Thus the food allocation constraint for fruit can be expressed as

$$46 - \sum_{i=1}^{18} a_i x_i \leq 0 \quad [3.18]$$

This means that fruits production must at least meet household subsistence requirements.

Food allocation constraint for minor crops

According to Latham (1979) and FAO/WHO (1973) standards, the protein content of minor crops is 229 g-protein/kg. Survey results in Mhonda village show that minor crops contribute about 1 percent of annual household protein needs. Thus the quantity of minor crops required for household subsistence can be expressed as

$$\frac{0.01 \times 109\,500 \text{ g-protein/year}}{229 \text{ g-protein/kg}} = 5 \text{ kg/year}$$

Thus the food allocation constraint for minor crops can be expressed as follows

$$5 - \sum_{i=1}^{13} a_i x_i \leq 0 \quad [3.19]$$

This means that minor crops produced must at least meet subsistence requirements.

3.2.2.12 Land area constraint

Mhonda village is located on the eastern slopes of the Nguru mountains where due to the presence of numerous rivers and streams the land surface is substantially dissected. Consequently the total farming land comprises of both lowland and upland. Each of these land types is subjected to different use. Whereas rice, maize, beans and vegetables can flourish in lowland, maize, beans and other crops can grow in upland. In this study all land with slope < 10% is regarded as lowland whereas land with slope > 10% is regarded as upland. Survey results in the village show that 40% of all land under agriculture is in lowland zone and for an average peasant farmer in Mhonda village it is limited to 1.0 hectare. Upland comprise of 60% of all land under agriculture and for an average peasant farmer in Mhonda village is limited to 1.5 hectares. Thus an average household has an average farm size of 2.5 hectares divided into 2.5 plots per household. Since agriculture in the village is mainly rainfed type, it is important to distinguish between "long rain land" and "short rain land" for those crop categories which depend on seasonality of rainfall. It is also important to consider that some fields can be multiply-cropped while others are mixed or intercropped.

Based on these facts, the long rain land area constraint is:

$$\sum x_i \leq 2.5 \quad [3.20]$$

where, i = all crops grown during long rain season.

The short rain land area constraint is:

$$\sum x_i \leq 2.5 \quad [3.21]$$

where, i = all crops grown during short rain season.

Lowland area constraint is:

$$\sum x_i \leq 1.0 \quad [3.22]$$

where i = all crops grown in lowland.

Upland area constraint is:

$$\sum x_i \leq 1.5 \quad [3.23]$$

where, i = all crops grown in upland.

3.2.2.13 non-negative restrictions

The non-negative constraints for decision variables are as follows:

$$X_i \geq 0 \quad (i= 1,2,\dots,18). \quad [3.24]$$

$$X_n \geq 0 \quad [3.25]$$

$$X_p \geq 0 \quad [3.26]$$

$$X_k \geq 0 \quad [3.27]$$

$$c_i \geq 0 \quad (i = 1,2,\dots,9). \quad [3.28]$$

3.2.2.14 The detached coefficient matrix for the model inputs

Based on tables 4.22, 4.23, 4.24, 4.25, 4.26 and 4.27 and omitting the non-negative restrictions, the detached coefficient matrix for the model was completed and is presented in Appendix 5. The data input file for the basic model is presented in Appendix 6. In the data input file and the matrix, labour constraints are limited to peak months only because it is during these months when labour availability could be limiting (i.e. labour requirements relative to supply is critical). These months are identified in table 4.13. The working capital limit includes working capital and cost of fertilizers. This money may be obtained from household balance at start of farming season, institutional credit and/or credit from local money lenders.

3.2.2.15 Optimization and sensitivity analysis

The basic model formulation was optimized by making several runs. These were followed by sensitivity analysis. In sensitivity "what if" questions based on positive economic principles were asked to assess the impact of changes in crop farmgate prices, total capital, population growth, changes in farming land area, income, effect of relaxing labour supply constraints and effect of increasing fertilizer price on its use were analyzed. The procedure used can be illustrated as follows. In the basic model the vector, B, presented in equation [3.2] can be changed to, B*, so that $B = (b_1, b_2, b_3), \dots, b_i, \dots, b_m)$ becomes $B^* = (b_1, b_2, b_3, \dots, b_i^*, \dots, b_m)$ where $b_i^* = b_i + \Theta$ and, $\Theta > 0$. The effect of such a change on the production function is then investigated by modifying the basic model accordingly to

$$\text{Max} \quad Z = C'X \quad [3.29]$$

$$\text{Subject to} \quad AX \leq B^* \quad [3.30]$$

$$X \geq 0 \quad [3.31]$$

where Z = objective function

X = is an nx1 vector of activities or processes

C = is an nx1 vector of unit prices and unit costs for each process

A = is the mxn matrix of input-output coefficients, and

B = is the mx1 vector of resource supplies and other constraints included in the model.

For instance, if b_i is the initial household farm holding of 2.5 ha, then b_i^* could represent the reduced farm size of say 1.0 ha when the farm is subdivided among children or an increased farm size of 3.5 ha if the farmer succeeds to expand the farm size through say, new land clearing. The

effect of such changes on the production function were investigated on the basis of new resource supply levels. Normative economic theory was used to explain the farmer's behaviour on these changes. Also the impact of population growth on farming land availability was evaluated. In general, the purpose of sensitivity analysis was to test the model solutions to changes in some key variables. It reveals what input parameters are most critical in determining the solution and therefore require more careful estimation. Also is useful in estimating elasticities such as for deforestation pressure.

3.2.2.16 Analysis of impact of agriculture on deforestation pressure

Impact of changes in total land area and food consumption due to population growth

The model base scenarios do not include land clearing activities caused by bush clearing in unprotected woodlands and encroachment in the forest reserve. Since land clearing is an important activity related to deforestation and environmental degradation, it was felt important to expand the model to include land clearing activities so as to accommodate the need for expanding farmlands emanating from population growth and other factors. Population growth is introduced in this case as a dynamic factor and therefore it introduces periodic changes in the model parameters.

Thus the major aim of the extended model is to analyze the effect of population growth in relation to deforestation over time under the assumption of non-declining household food consumption and income. In addition to assuming constant farming technology, this analysis also assumes that clearing of new land is done using family labour only and that no labour will be hired for clearing forest lands. Furthermore it is assumed that land clearing takes place only when there is real demand for new land. This is due to the fact that forest land clearing is an arduous task which is often undesirable unless it is absolutely imperative. Another aim of the analysis is to examine the sustainability of farming systems over time in light of constant farming technology and assumed population growth rate. The underlying assumption in this analysis is that population growth causes deforestation and this being a consequence of derived demand for household food and cash income. In this case land clearing is a dynamic factor in an otherwise static planning framework as it affects both present and future incomes. The extended model incorporating land clearing activities is made such that in any given year, the total cropped land equals the sum of available land and cleared land in the previous period. Mathematically this can be expressed as follows:

$$A_t = A_{t-1} + dA_t \quad [3.32]$$

where, A_t = total cropped land in year t , where $t = 5, 15, 25, 35$.

A_{t-1} = available land in previous period/year

dA_t = new cleared land just before period t

The new land clearing activities that were incorporated into the models are defined as follows:

LR_t = long rain land cleared in year t ,

SR_t = short rain land cleared in year t ,

VR_t = vegetable/rice land cleared in year t ,

t = time periods t , where $t = 5, 15, 25, 35$.

Such that in any given period the total cleared land is represented by the equation:

$$CdA_t = LR_t + SR_t + VR_t \quad [3.33]$$

where, CdA_t = total cleared land in year t .

Other symbols remain as defined earlier.

New land clearing is obtained by compounding available land in the previous year/period by the population growth rate. This is based on the assumption that demand for new land increases at the same rate as population growth because food consumption increases with increase in number of people. Mathematically this can be expressed as follows:

$$A_t = A_{t-1}(1+i)^t \quad [3.34]$$

where, A_{t-1} = available land in year $t-1$ and

i = population growth rate (which is 2.6% for Morogoro Rural District where the study area is located (URT 1988)).

In Mhonda village new land clearing is men's task due to its arduous nature. Data collected in the village show that an average of 50 mandays per hectare are required to clear land in a new site. This also requires an additional working capital of T.Shs. 25 000 per hectare. This additional working capital is for purchase of additional hand tools for felling trees such as bowsaws, cross-cut saws, axes, hoes, slashers and bush-knives according to the needs of the household. Besides land clearing activities in the extended model, other adjustments were instituted to reflect changes brought about by incorporation of land clearing activities. These adjustments relate to labour, working capital and land area constraints. Moreover one more row was added to represent an accounting equation for total land clearing such that this equation together with the lower bound for income ensure that household income and food consumption from own farm met minimum levels. The purpose of this provision is that household income should not fall below a certain minimum if the welfare level is to be sustained (increased) over time. The accounting equation for total land clearing aims at allowing the model to compute value of cleared land in each period.

In this analysis, population growth rate is also assumed to be a proxy for estimating increase in household food consumption. Hence the dynamic factor in the model, population, increases the demand for food. Moreover, household food consumption patterns and types of food consumed are assumed to remain unchanged over a planning horizon. Based on these assumptions, household food consumption at future periods was estimated exogenously by compounding (using population growth rate) base year consumption values. In this case base year food consumption refers to values in the existing farm plan. Base year food consumption and future period food consumption are related by the following equation:

$$C_t = C_o(1+i)^t \quad [3.35]$$

where, C_t = kg of household food consumption in year t ,

(where $t = 5, 10, 15, 20, 25, 30, 35$).

C_o = kg of household food consumption in the base year (present time)

i = population growth rate (expressed as a decimal).

t = time period

It is further assumed in this analysis that all farm households in the village equally strive to gain high welfare standard. From survey data, the baseline value of annual household total net income in Mhonda village is fairly low. Most of this income is earned from agriculture and local enterprises. The low total value of the average household income level for the village reflects the low standard of living caused by poor socio-economic conditions in the village. In the extended model, it is hypothesized that farmer's households in Mhonda village, due to their poor socio-economic conditions have a motive to clear the land and in so doing cause land degradation and deforestation. The motive behind land clearing is to increase food production and to earn cash income by expanding farm area. The runs for the extended model, incorporating land clearing activities entails two basic scenarios described as follows:

Scenario 1: Assuming a population growth rate of 2.6 percent per annum, over a period of 35 years while holding household cash income and food consumption from own farm non-declining.

Scenario 2: Assuming a population growth rate of 3.5 percent per annum, over a period of 35 years while holding per capita cash income and food consumption from own farm non-declining. The analysis of the pressure on forest lands as a result of agriculture initiated by population growth involved simulation of the above scenarios in the model and the results are presented in tables 4.32 and 4.33 representing scenarios 1 and 2 respectively. Elasticities for deforestation pressure were also estimated.

Impact of price changes on total net income (farmer's gross margin)

To investigate how the optimum farm plan is altered due to changes in producer prices, prices of each crop (mid 1994 prices) were increased by 10, 20 percent and more. The results of this sensitivity analysis are presented in table 4.35.

Effect of changes of total working capital on the use of resources and deforestation

The lack of cash among peasants impairs their ability to purchase inputs for servicing agriculture. In consequence peasants are made to adopt poor landuse practices which cause land degradation and deforestation. Therefore it seems plausible to investigate the effect of total working capital changes on landuse pattern and deforestation. The analysis also need to be extended to explain the effect of total working capital availability on use of market agricultural inputs particularly the fertilizers, nitrogen and phosphorus. It is conceived that the use of these market agricultural inputs is a derived demand in the sense that farmer's intensity of using these inputs depends on availability of working capital in form of earned money or transfers from lending institutions and individuals. To conduct this analysis, three alternative scenarios were investigated. In scenario 1, there is no land clearing and working capital is unrestricted. In scenario 2, land clearing is allowed under restricted working capital condition. In scenario 3, land clearing is allowed under unrestricted working capital condition. Table 4.36 summarizes the results of this analysis.

Effect of increasing fertilizer price

Withdrawal of fertilizer subsidy is one important component recommended in the ongoing process of structural adjustment and its implementation increases the price of fertilizer. The

purpose of sensitivity analysis on fertilizer price is to investigate the likely impact of fertilizer price increase on the use of fertilizer. The existing fertilizer price was increased by 5, 10 and 15 percent for both nitrogen and phosphorus. The results are presented in table 4.37.

Experimentation and sensitivity analysis with stochastic variables

Experimentation with stochastic variables was accomplished by running the quadratic model to compute efficient compromise solutions using L_1 , L_2 and L_∞ metrics. Sensitivity analysis was conducted by assigning subjective weights to the three objectives being compromised. Five scenarios were analyzed each having different weights for the objectives shown in table 3.2. In general the sensitivity analysis scenarios entailed assigning equal weights to all objectives or increasing the weight of one or two objectives relative to those of another objective.

More specifically, the different scenarios can be explained as follows: In scenario 1, equal weights are assigned to the three objectives such that $\delta_1 = \delta_2 = \delta_3$ (1:1:1). This implies that the three objectives are of equal importance to the farmer. In scenario 2, the farmer (i.e. the decision maker) puts more weight on maximization of net cash income than minimization of risk and labour use variability (5:1:1). In Scenario 3, the farmer assigns more weight on risk minimization than on maximization of net cash income and minimization of labour use variability (1:5:1). In scenario 4, the farmer assigns more weight on minimization of labour use variability than on maximization of net cash income and minimization of risk (1:1:5). In Scenario 5, the farmer assigns greater weight to risk minimization and minimization of labour use variability than on maximization of net cash income (1:5:5).

Table 3.2 Different scenarios and subjective weights used for sensitivity analysis with stochastic models.

Scenario	Subjective ¹ weights for different objectives		
	Maximization of total net income (δ_1)	Minimization of risk (δ_2)	Minimization of labour use variability (δ_3)
1	1	1	1
2	5	1	1
3	1	5	1
4	1	1	5
5	1	5	5

Footnote: 1 These are subjective weights because the farmer's discretion is the guiding criterion in choosing the weights under different scenarios. The assumption is that the farmer often values objectives differently.

On the basis of these weights in the different scenarios, compromise solutions for L_1 , L_2 and L_∞ metrics were generated by compromising the three objectives. The wide range of efficient farm plans were generated (tables 4.38, 4.39 and 4.40) through these sensitivity analyzes indicating wide choice for the decision maker (i.e. farmer) in accordance with his preferences.

4.0 RESULTS AND DISCUSSIONS

4.1 Survey results and discussions

4.1.1 Input resource availability, utilization and productivity

The purpose of this present section is to give a summary of resources availability and utilization at household level in Mhonda village as found during the survey and other materials cited in line with the objectives of this study and to assess the productivity of the factors of production namely land, labour, capital and entrepreneurship. This presentation is important for identifying and understanding the constraints to efficient production at the household farm level. It is also a prerequisite for construction of a realistic mathematical programming model which can generate optimal farm plans at household farm level.

4.1.1.1 Land availability and utilization

Land tenure system

The intensity of agricultural production is affected by the land tenure system which prevail in the study area. Similarly access of individuals to land is influenced by the land tenure system. Any review of land ownership, distribution and use must therefore be preceded by looking into land tenure aspects. There are four types of land tenure arrangements prevalent in Tanzania. These are customary, communal, leasehold and rights of occupancy (Mnzava & Riihinen 1989). Survey results show that up to 90 percent of the land in Mhonda village is held according to customary land tenure arrangements. In this arrangement, land on which to grow crops is the most important capital asset needed by all farming households. Access to this land is through a patrilineal clan-land inheritance system in which children (mainly male) inherit the right of use of the land from their fathers but land itself remains a property of the clan. Children belong to their father's clan and women cannot inherit land from their husbands. Hence women, despite their significant role in agriculture have an indirect and insecure access to land. This is a disincentive to this important group in terms of investment and innovations.

Out of the sampled households 77 percent acknowledged that household land was owned by the male head of household and only 13 percent said it was owned by a female spouse. Even in terms of the use of household land 70 percent of respondents indicated that the decision about what crops to grow on the farm was made by the male head of household. Only 30 percent said the decision is made by both husband and wife. The patrilineal tenure arrangement in Mhonda village also implies that children born out of the marriage wedlock are essentially landless because they fall outside the patriarchal clan land-inheritance system. Their security in the future lies only in the increasing buying and selling of land likely to be brought by land shortage as a result of population pressure and declining soil fertility. About 13 percent of respondents reported that population pressure has in recent years become the main cause of land shrinkage in the village.

Although land remains the property of the clan, the individual enjoys some degree of freedom to sell his user rights and in this sense land, is therefore a *de facto* private property and the current price of a farm is about T.Shs. 25 000 per hectare because land is poorly improved. Customarily, land in Mhonda village can also be acquired through marriage whereby the bridegroom is leased a portion of land for arable agriculture by his father in law.

Theoretically, access to land in Tanzania is guaranteed by the state which according to the law (Cap 113) all land in Tanzania belongs to the state. This refers to "granted right of occupancy" as given under the law. However, this does not function well due to customary laws on the basis of which lineage membership give individuals the right to live and cultivate on lineage land. Since people do not give up land voluntarily, the government seem to have incorporated this in its present land policy under what is referred to as "deemed right of occupancy".

The present government land policy allows an individual to hold and use land or allows an individual to hold land as long as he uses it or has made some improvement on it such as growing some trees. This is the "right of occupancy system" (TFAP 1989, National Land Policy 1993). This implies that people wishing to expand farms can do so by inheriting from parents or by clearing forest land. The latter is possible because the customary land tenure system allows the opening of new lands outside the designated village area (Villages and Ujamaa villages Act 1975). Moreover, borrowing and renting of land is also possible mainly for new coming immigrants ("outsiders") to the village. One old practice is the "Ngoto" system of payment by "outsiders". It involves a payment for the use of land by a farm household which had migrated to the village particularly to the Wanguu tribesmen. The payment is generally a share of the crop produced on the land. The share going to the controller of the land cannot be sold. This practice has been borrowed from the matrilineal Waluguru tribe which live in the neighborhood of the Wanguu tribe. Slowly the practice is fading away because most households no longer have extra land for lending or leasing out.

Besides the "Ngoto" system, "outsiders" coming to the village can acquire land through the formalities of the "Village and Ujamaa villages Act" of 1975 which in strict terms applies most to newcomers than indigenous villagers. The reason is that while village natives acquire most of the land through lineage inheritance, immigrants have to follow a formal procedure to acquire land through the village council in which land allocation powers are vested by the Village and Ujamaa villages Act" of 1975. According to this Act, the government is to demarcate land and then villages are granted titles to use these lands (rights of occupancy as given under the law) for 99 years. Land allocation decisions can then be made by village authority which is the village council (Kowero 1990, World Bank 1992).

Table 4.1 presents the methods used in the acquisition or legitimization of land ownership in Mhonda village. The methods of acquiring land form an important subject in this study because of their strong bearing on ecological degradation culminating into deforestation. In the model the effect of forest land clearing to acquire additional land for agriculture is analyzed.

Table 4.1 Methods used to acquire land for farming in Mhonda village (N = 77)

Method of land acquisition	# of households (frequency)	Percent
Inheritance	71	92.2
Bought	0	0
Village offer	4	5.2
Lease	0	0
Clearing forest	2	2.6
Other	0	0

Source: Own field data

The results show that land acquisition through inheritance is dominant in the village. It was learnt from the village leaders that the land acquired through buying is mainly for immigrants to the village who do not reside in the village hence were not sampled. Indigenous villagers rarely purchase land due to lack of cash and have no tradition to buy land. Leasing out or lending of land have diminished in the village. Forest clearing as a method to claim or acquire land is practiced. Table 4.2 presents some methods used to acquire additional land in Mhonda village.

Table 4.2. Methods for acquisition of additional land in Mhonda village (N = 77).

Method of additional land acquisition	# of households	Percent
Inheritance	59	76.6
Forest land clearing	13	16.9
Reverting to fallow land	3	3.9
Buying	0	0
Village allocation	2	2.6
Other	0	0

Source: Own field data.

As for acquisition of land, most additional land is acquired by inheritance. Also a substantial proportion of additional land is acquired through forest land clearing. Desperate farmers sometimes decide to encroach the forest deliberately or through ambivalent behaviour. The tendency to invade the forest is an indication that additional land is not easily available for some farm households. Ironically, the presence of the possibility to revert to fallow land also indicate that some households control more land than they can actually use to the extent that they let

some of the land lie fallow while others look for more. An average fallow period of 3 years after 2-3 cropping seasons is still practiced by those households which own land above average needs. Quite few respondents have farmholdings above the 2.5 ha mean size and such big holdings are in the range 3 - 6 ha per household. Such vast land per household is owned under the customary land tenure arrangement and is an indication of some setbacks or failures of the customary land tenure system in unequal distribution of land. The consequence of this is to create artificial land scarcity while some individual households own more land than they actually need at the same time not willing to lease it to others especially the landless or those with plots below average size.

Other data on farm land acquisition can be summarized as follows:

About 93.3 percent of respondents acknowledged that they have used their farms for more than 5 years while about 7 percent acquired their farms within the last 1-2 year period. 43 percent of the respondents lacked land of their own hence had to engage in activities other than farming own land. Also when asked how much additional land they would need, 50 percent of the respondents showed that they would need more than 3 acres (1.2 ha). This implies that the land they currently cultivate was apparently below their needs. None of the respondents needed less than 1 acre (0.4 ha). The unavailability of land to some farm households points ominously towards the need for re-examining land policies. Clearly the land tenure system is difficult to modify when government policy itself sets property rights. In the study area, more than 90 percent of the respondents agreed that they had customary rights on the land, 30 percent had property rights on the land only when they were using it, 20 percent had their rights protected by the village, 7 percent had title deeds and 13 percent had no claims over the land they were using.

According to the National Land Policy (1993) and National Agricultural Policy (1982) the government of Tanzania in its attempt to restrict the growth of rural capitalism, until recently, used to restrain the land tenure system in rural areas (including Mhonda village) by applying the following principles:

- (i) allocation of land to villages on a basis of long term leases (99 years).
- (ii) Allowing villages to sub-allocate land to any household for the entire period or any shorter period.
- (iii) Sub-allocation of village land must be done in consultation with government agencies. A land tenure arrangement emphasizing conservation, utilization and improvement of land is encouraged with consideration for traditional practices and beliefs.
- (iv) Restricting each farm household from free sale of the land leased to them by the village. The lease may be surrendered to the village and compensation paid for any improvements and/or permanent crops given up.

The customary land tenure system embodies within itself checks and balances which ensure that land distribution and use caters for the interests of individuals as well as those of the traditional society. The immigration of people from distant places with cash money to buy land coupled with peasants urge for cash to buy market goods is slowly eroding traditional norms of land tenure in the study area.

Farm layout, size and distribution of holdings

The existing production plan of a typical household farm in Mhonda village involves the cultivation of crops described in section 3.2.2.1. On these farms, besides agricultural crops, can be seen natural trees left to grow inside the farm or on its periphery for fuelwood or even timber. Some fruit trees mainly pawpaw and coconut are also interplanted with crops. Survey results show that 47 percent of the respondents have natural trees left on their farms. This is some kind of undeliberate "traditional agroforestry". The typical trees left are multi-purpose trees such as *Syzigium cumini* (fuelwood and fruits), *mangifera indica* (fuelwood and fruit), *Anona spp* (fruit and fuelwood) *Sena siamea* (fuelwood and building poles).

On the whole farm size is in the range of 2-5 ha, with the mean size of 2.5 ha. of which 40 percent lie in lowland and 60 percent lie in upland. Since the village has 546 households, the average total cultivated land in the village is about 1365 hectares. 53 percent of the respondents in the village conceded that their farm holdings were adequate while 47 percent indicated that this was inadequate. In terms of farm distribution, enumerated farm holdings are distributed on an average of 2.5 plots per household. Thus farm plots for most households were fragmented. Out of the total respondents, 70 percent said their farms were not in a single block. The distance of holdings from homesteads is in the range 1-5 km and the mean distance is 1.4 km. The fact that some farm holdings are located at distances of 3-5 km (23 percent of respondents) indicates that there is difficulty in acquiring land for some households. Actually 87 percent of the respondents indicated that their farms were not close to homesteads due to lack of land near homesteads. 33 percent indicated that they cultivated at long distances in their quest for fertile land.

4.1.1.2 Labour supply and demand

Demographic data in Mhonda village

In Africa, labour is one of the most important factors of production in peasant agriculture (Low 1986). In the study area, labour is provided largely by individual household members. Adults supply most of the farming labour while children supply labour for light farming activities such as pest scaring. Hired labour is of less importance. Thus household demographic and personal data for an average farmer were collected to assess the supply of labour for agricultural production in Mhonda village. The village had 3822 inhabitants (as at June 1994) who live in 546 households. The village register also indicated that there were 1100 people able to work actively. The rest were old people above 65 years, children below 8 years and disabled people. The mean family size was 7 people. This is rather a big family size to support. However, it is generally widely established that in traditional agriculture a positive correlation exists between land and labour because land productivity is low and increases in family size necessitate expansion of farm holdings in order to maintain a constant per capita consumption (Tibajuka 1984).

Household labour supply and demand, timing of operations and agricultural calendar

Land and labour remain the most important inputs in peasant farming systems and most of the

labour is family labour. Sex and age are the most important demographic characteristics influencing labour supply in peasant societies (Beets 1990). However, like any other factor of production there are several competing ends to which labour must be allocated. There are also several bottlenecks such as ill-health, social activities and customs which can tie down labour diverting it from productive employment. In planning agricultural production knowledge of the proportion of labour stock that can be expected to flow to farming is necessary. Thus an estimation of household labour stock was undertaken based on the analysis of sex and age composition and by using a scheme of weights (coefficients) which made it possible to aggregate household labour in adult or man-equivalents (ME). The choice of weights (coefficients) used in converting child and female labour to adult or man equivalents is based on weights used by Due, *et al.* (1984). Based on these weights, adult or man-equivalents in full-time farming are as follows:

Adult male and female, 18 years and over are coded 1.0.

Males and females 12-17 years are coded 0.5.

Males and females 8-11 years are coded 0.3.

Persons farming less than 12 months are coded by taking the percentage of the time in the year they participated in farming. For example, 9 months is 0.8. This apply to family members who are in the household for less than 12 months and children in school who are available for farmwork only during holidays and after school.

The respondents in Mhonda village maintained that there is not much clear demarcation between adult male and adult female labour in terms of farming except for some very specialized tasks (see also table 4.3). Gender becomes important when carrying out domestic chores which are mainly carried out by women. Thus in weighting farm labour, despite male greater physical power, performance of farm operations is relatively equally done by both males and females. The differences due to dexterity and prowess in performing some operations do not count much because the will to work and actual performance on the farm is the same for adult males and females. Thus the main assumption here is that male and female labour are sufficiently substitutable, implying that the model did not explicitly incorporate the gender specific division of labour within the household, but assumed that the overall productive capacity of work was the same for both males and females.

This assumption is based on the fact that, besides the participation of different sexes in various activities, no study was conducted to exactly compare the productivity of male and female labour productivities based on the actual division of labour. Moreover the separation of male and female labour would also have required a considerable extension of the model. In any case it would have been more relevant to give more prowess for work to males for tasks referred to as male activities and high dexterity to females for activities referred to as female activities. Nonetheless the error from pooling male and female labour would be greatest for households with large imbalance in male versus female labour and under conditions with very strict division of labour. This is not the case in Mhonda village. Holden (1991) in his analytical model for the Chitemene system in northern Zambia assumed a similar situation regarding division of household farm labour among sexes. Mlambiti (1985) notes that the capacity of a given labour force, besides other factors, is governed largely by the will to work. The organization of farm activities in

Mhonda village suggest that both males and females have the same will to farm work on the understanding that it is the basis of the household livelihood. Nevertheless, women in addition to economic activities have to attend to domestic chores which men hardly participate, consequently they have only a limited amount of leisure compared to men. The participation of different sexes and age groups in household activities is shown in table 4.3. Since women are involved in almost all activities on the farm even on so called male activities, they make a significant contribution to household labour. Thus the belief that men are responsible for major crops turns out to be "a myth" as Swantz (1984) asserts.

Table 4.3 Participation of household members in various activities (N = 77)

Activity category	% of participating household members			
	Men	Boys	Women	Girls
Feeding family	50	13	90	47
Fetching water and fuelwood	7	13	80	90
Land preparation	97	77	77	60
Sowing & planting	80	90	90	83
Weeding	93	87	90	77
Fertilizer application	7	7	7	7
Chemical spraying	10	7	7	7
Harvesting	93	90	90	90
Processing & storage	73	53	77	60
Marketing	53	47	63	43
Tree planting	50	17	17	10
Tree protection	73	30	33	33

Source: Own field data

As can be noted, female children take up the responsibility of fetching water and fuelwood. Survey results also showed that they take part in cooking and taking care of infants. This sometimes releases female labour from farmwork. The seasonality of labour in Mhonda village can be seen from the agricultural calendar by crop and by operation compiled and presented in tables 4.4 and 4.5 respectively. It can be observed that seasonal labour demands presented in table 4.13 coincide with farming activities over the year. Moreover seasonal labour peaks correspond with the onset of the two rainy seasons: March-May and October-December. The major farming operations/activities included in this analysis are land preparation, planting, weeding, fertilizer application, chemical spraying and harvesting (which in this case includes storage, transportation and marketing). These activities often overlap between periods hence are sometimes carried out concurrently. Sometimes some activities are combined to minimize cost and to save time. Others are sometimes skipped due to lack of inputs such as labour, tools, chemicals, or fertilizer.

The aim of the agricultural calendar therefore is simply to provide a general idea of what type of labour requirements might be anticipated. One would expect, correctly, that the time period February-April would require maximum labour availability. So is the time period September-December. These are associated with land preparation, planting, weeding and pest removal activities converging upon one another hence creating a labour bottleneck. It is specifically this type of constraint which is amenable to increased flexibility. Also the harvesting-marketing period of May through August represents another potential labour bottleneck. The crop calendar represents the periods where labour must be allocated to these activities. It does not represent the actual amount of labour which is available during these periods.

Table 4.4 Agricultural calendar by crop for Mhonda village.

Crop	January	February	March	April	May	June	July	August	September	October	November	December
Maize	LP - W1 - H	LP P F W1 - H	LP P F W1 W2 -	- P F W1 W2 H	- - - W2 H	- - - - H	- - - - -	- M - - -	LP M - - -	LP M - - -	LP P F - -	LP P F W1 -
Beans	- - W1 - H	- - W1 - H	LP P F - -	LP P F W1 -	LP P - W1 W2 -	- - - W1 W2 -	- - - W2 H	- - - - H	LP - - - -	LP - - - -	LP P F - -	LP P F W1 -
Cassava	LP P - - -	LP P W1 - -	LP P W1 - -	- - W2 -	- - W2 -	- - - -	- - - -	- - - H	LP P W1 - H	LP P - - H	LP P - W1 H	LP P - W1 H
"Other crops"	LP P - W1 - H	LP P F W1 W2 H	LP P F W1 W2 H	LP P - - W2 H	- - - W2 H	- - - W2 -	- - - W2 -	M P M W1 -	LP P - - -	LP P F - -	LP P F W1 -	LP P - - -

Source: Own field data.

Key: LP = Land preparation (includes bush clearing); P = Planting; W1 = First weeding;
W2 = Second weeding; H = Harvesting (includes transportation, storage and marketing activities);
F = Fertilizer application; M = Manure application.

Since rainfed agriculture is practiced, the timing of the various operations carried out in farming is such that maximum use of rainfall is achieved. However, this very much depends on the size of the farm relative to the availability of labour and type of crop grown. For example, land preparation is normally carried out prior to the onset of the rain seasons whereas planting is carried out as soon as rains start. Vegetables require more labour in land preparation than maize and beans etc.

Table 4.5 Agricultural calendar by operation (activity) for Mhonda village

Type of rain season	Farm activity	Months in which farm activity is carried out
Short rain ("vuli")	LC	September, October
	LP	September, October, November
	M ¹	September, October
	P	November, December
	W1	November, December, January
	W2	December, January
	F	December, January
	S	December, January
	H ²	February, March, April
Long rain ("masika")	LC	January, February
	LP	January, February
	M	February, March
	P	February, March
	W1	March, April
	W2	April, May
	F	March, April
	S	April, March
	H	May, June, July, August

Source: Own field data

Key: LP = Land preparation; P = Planting; W1 = First weeding; W2 = Second weeding; H = Harvesting (includes transportation, storage and marketing activities); F = Fertilizer application; M = Manure application; LC = Land clearing; S = Chemical spraying.

Footnote: 1 = fertilizer and manure application in both seasons is sometimes carried out twice. However, the second application is optional for most households due to inadequacy of available fertilizer and manure.
2 = harvesting includes activities such as storage, transportation and marketing.

As can be noted from the agricultural calendar in table 4.4, maize and beans are grown twice (i.e. during short and long rains). Maize demands adequate moisture throughout the growth period which is relatively long, thus there are often maize crop failures due to erratic nature of short rains in the village. Other crops are planted once per year and mainly during the long rains. Cassava is planted mainly during short rains and continues to grow during the long rain season. However during the onset of long rains, some enrichment planting or planting for gap filling takes place. Also those households which failed to plant cassava during short rains season due to labour shortage, carry out the planting during long rain season. Fertilizer application depends on the availability of fertilizer. So is the spraying of chemicals. Often the second application of fertilizer and chemical, like second weeding are optional activities to most households. They are often not carried out. Table 4.6 presents per hectare labour requirements by crop in Mhonda village. The calculations are based on an average 9 hour working day if each crop was put under monoculture cropping system. Maize, cassava, rice and vegetable feature to be high labour consuming crops compared to others.

Monthly labour allocation and requirement in Mhonda village

One of the most important problems in peasant agricultural production is the seasonality of labour requirements. Often labour demand by agricultural activities varies substantially between seasons. There are peak months when members of a household are more active and slack months when there is surplus labour (table 4.13). Therefore in studying agricultural systems in the village, the allocation of labour by month and enterprise or operation becomes one important aspect. Such analysis is crucial in identifying labour bottleneck periods and hence can assist in identifying required changes in the farming system to even-out monthly labour demand and allocation of labour as efficiently as possible. In the analysis carried out in this study for stochastic variables, minimization of labour use variation forms one objective function whose aim is to smooth out the differences between labour supply and demand by months over the year.

The calculation of labour demand and supply per hectare by month and by crop is calculated in tables 4.6, 4.8, 4.9 4.10, 4.11, 4.12 and 4.13. The basic assumption is that labour supply in any calendar month cannot exceed the number of effective working days. Also for any farming activity, labour supply equals effective household labour. Labour is highly demanded during the months when farming is at the peak. There is labour slackening during the dry season when farming activities are limited to few activities such as land clearing and weeding for crops like cassava. Some activities like land preparation and weeding are more labour demanding than others as shown in table 4.6. Survey results in Mhonda village indicate that an average typical peasant household has 7 persons of which 2 are adults 18 years and over, 2 are between 12-17 years and 3 are between 8-11 years. Children below 8 years do not participate in farming activities. Based on these facts and coefficients by Due *et al.* (1984) (refer also section 4.1.1.2), the average adult or man-equivalents (ME) for a household in Mhonda village is calculated as 3.9. From this figure, the calculation of effective adult-equivalent mandays per month for a typical household in Mhonda village is as shown in table 4.8. These monthly labour supplies per farm household are used as RHS for the labour constraints. Each monthly labour supply indicates the maximum level of available labour in that month.

Table 4.6. Per hectare labour demand by crop and by activity in one season in Mhonda village.

Farming activity	Labour requirements (ME-mandays/ha)								
	M	B	C	R	S	V	Ba	FR	Mc
Land preparation	5	3	6	8	4	7	2	0	0
Planting	4	4	7	12	2	2	3	0	0
First weeding	8	6	12	13	6	9	2	2	1
Fertilizer applic.	3	2	0	11	5	5	2	3	2
Manure applic.	2	2	2	15	7	3	3	1	1
chemical spraying	2	2	1	13	9	5	0	0	1
Second weeding	4	3	8	9	4	3	0	0	0
Harvesting	3	2	5	7	2	4	0	0	0
Transportation	1	1	3	9	3	7	0	0	0
Storage	3	2	3	10	1	2	0	1	0
Marketing	2	3	0	9	2	3	2	2	0
TOTAL	37	30	47	116	45	50	14	9	5

Source: Own field data

Experience in Mhonda village show that during months in which labour demand is at its peak, other jobs which compete for labour are foregone. Consequently a 9 hour average working day is practiced for farming activities. However, it is estimated that nearly 10 hours is a maximum amount of labour time that can be supplied for farming at peak labour periods. In Mhonda village farmers were found to work longer hours than the official hours (rate) at an average of 9 hours per day due to the fact that most peasant farmers do not have an afternoon meal break particularly when their plots are away from homesteads. One meal a day is a very common practice.

Table 4.7 Respondent's ranking of peak or busiest months in Mhonda village (N = 77).

Month	Percent (%)
January	94
February	80
March	67
April	22
May	13
June	7
July	4
August	7
September	27
October	7
November	86
December	93

Source: Own field data

The monthly labour demand per hectare by crop is shown in table 4.9, 4.10, 4.11 and 4.12. It is calculated as the average labour requirement for all farming activities (operations) in each month associated with a crop under consideration from land preparation to marketing of crops by the household. More precisely the activities included are land preparation, planting, first and second weeding, fertilizer and manure application, chemical spraying, harvesting, transportation, storage and marketing. The per hectare labour demand by activity for various crops is presented in table 4.6. The per hectare total labour available versus total labour requirement per month is presented in table 4.13. Peak months for labour demand are those months in which required labour exceeds available labour. In table 4.13 these months are indicated by negative sign in the "differences" (i.e. last) column. The peak months are January, February, March, April, May, September, November and December. This concurs with respondents views in the interview survey who identified the same months as the peak or busiest months in a year (see table 4.7).

Table 4.8. Calculation of adult-equivalent mandays available per month for a typical household in Mhonda village.

(1)	(2)	(3)	(4)			(5)	(6)
Month	Total days in a month	Household ME's	Calculated available days			Net effective working days	Effective available ME-mandays per month
			Less				
			Sundays	Rainy days ^a	Holidays ^b		
						(2-4)	(3x5)
Jan	31	3.9	4	6	2	19	74
Feb	28	3.9	4	13	1	10	39
Mar	31	3.9	4	16	0	11	43
Apr	30	3.9	4	12	2	12	47
May	31	3.9	4	15	1	11	43
Jun	30	3.9	4	2	0	24	94
Jul	31	3.9	4	1	1	25	98
Aug	31	3.9	4	2	2	23	90
Sept	30	3.9	4	0	2	24	94
Oct	31	3.9	4	0	0	27	105
Nov	30	3.9	4	4	1	21	82
Dec	31	3.9	4	12	2	13	51
TOTAL	365	-	48	83	14	220	860

Source: Own field data

Footnote: a = Rainy days include sickdays and rest days. Average for rainy days is for 1989-92 as obtained from Mhonda Mission meteorological station
b = Local holidays refer to traditional festivities.

Household dependency (producer to consumer) ratio in Mhonda village

As earlier calculated, an average household in Mhonda village has 5.0 consumption units (based on FAO/WHO standards, 1973) and has 3.9 effective adult-equivalents (based on coefficients by Due *et al.*, 1984). Thus the dependency ratio or the producer to consumer ratio (also referred to as worker/consumer ratio) using aggregated labour and aggregated consumer units is 0.8. This implies that for every adult (ME) there are 1.3 consumption units to support. Critically this poses a dependency burden on the already impoverished households in Mhonda village. The poor socio-economic welfare conditions prevalent in the village is a clear testimony of this burden. Unless agricultural intensification takes place, people's welfare in the village inclines towards continued decline. Alternatively, due to low land productivity people will expand farm holdings in order to maintain a constant per capita consumption. The obvious consequence is new land clearing whose impact on deforestation cannot be underestimated.

4.1.1.3 Capital resources available

In peasant agriculture the use of capital is very limited. Hence capital features as one of the factors limiting productivity because its shortage limits the degree of utilization of land and labour, the other two factors of production. As a factor of production capital is defined as "a stock which has value as a source of current and future flows of output and income" (Palgrave 1987). It is also defined as a produced good that can be used as a factor of input for further production (Tibaijuka 1984). In the village environment the physical capital stock of the farm households is very limited. It often includes such items as simple tools and equipment, crop storage structures and livestock buildings, stock of inputs like seeds, fertilizers and pesticides, livestock and improvements made on land such as fencing, drainage and irrigation facilities, terracing and tree crops. In addition to real capital employed directly on the farm there is money capital (liquid cash) that can be used to purchase goods and services needed in production.

However, to a farmer, most of the value tied up in capital is associated with the hoe. Hoes and machetes ("panga") would be used during weeding and harvesting respectively. The "panga" would also be useful in clearing new land or bringing fallowed land back into production. Table 4.14 presents working capital equipment owned per farm household in Mhonda village. The values are as at June 1994. From table 4.14 it can be observed that the type of working capital owned by peasant farm households in Mhonda village is a reflection of the simple technology used in farm production. Also it reflects that all operations depend on human muscle with the aid of simple tools as presented in table 4.14. Many of these tools and implements are worn out and cannot be easily replaced due to shortage or lack of cash.

In addition to working capital equipment peasant farm household in Mhonda village also own stocks of some farm inputs such as seeds saved from previous harvests, mostly grain and pulses. Often these are in small quantities only enough to meet seed requirements in the next planting season. The failure of farm households to replace worn out capital equipment is an indication that they do not have disposable liquid cash in form of working capital.

Table 4.9 Monthly labour requirement per hectare for crops under monocropping system in Mhonda village (ME-mandays).

Month	Crop under monocropping system							
	MSRU	MLRU	BSRU	BLRU	C	R	S	V
Jan	7	9	4	7	11	13	2	6
Feb	9	11	8	7	12	15	4	7
Mar	0	13	0	10	13	17	9	12
Apr	0	12	0	13	10	14	6	11
May	0	10	0	14	8	12	2	8
Jun	0	5	0	7	8	14	7	10
Jul	0	2	0	2	4	10	6	4
Aug	0	3	0	9	10	6	3	2
Sep	5	4	9	3	16	9	4	14
Oct	4	0	5	0	12	0	0	3
Nov	12	0	16	0	15	0	0	13
Dec	14	0	12	0	22	8	0	9

Source: Compiled from tables 4.4 and 4.6

Table 4.10 Monthly labour requirement per hectare for crops under mixed cropping system in Mhonda village (ME-mandays).

Months	Crops under mixed cropping system							
	SRM/B	LRM/B	M/S	C/B	M/B/C/S	Ba/C	FR/C	Mc
Jan	4	6	4	6	8	10	7	3
Feb	5	7	3	4	5	6	4	2
Mar	0	13	10	7	12	5	5	4
Apr	0	9	7	6	7	2	0	2
May	0	6	5	2	5	2	0	1
Jun	0	6	4	2	7	2	1	1
Jul	0	5	7	3	8	3	2	2
Aug	0	3	4	4	3	2	3	1
Sep	4	2	3	8	4	5	8	5
Oct	4	0	0	9	6	8	6	0
Nov	11	0	0	0	0	9	10	2
Dec	10	0	0	0	0	7	12	4

Source: Compiled from tables 4.4 and 4.6

However, efforts to get information on liquid cash balances on farm households failed for obvious reasons that nobody likes to expose his liquidity difficulties unless if such exposure can help to get some money. The total mean net worth or total equity of a peasant farm household in Mhonda village is estimated at T.Shs. 300 000. However, only about one percent of this amount is in liquid form. Having failed to get information on household liquid cash balances, then the mean net cash flow was estimated at the end of the survey year from farmer's daily reporting of cash incomes and expenditure. This is taken as a proxy measure of the household average cash balance at the start of a year and its value is T.Shs. 2500.

Table 4.11 Monthly labour requirement per hectare for crops under multiple cropping system in Mhonda village (ME-mandays).

Month	Crops under multiple cropping system	
	M/B	B
Jan	6	0
Feb	8	0
Mar	7	0
Apr	0	7
May	0	9
Jun	5	7
Jul	6	5
Aug	3	2
Sep	0	0
Oct	0	0
Nov	0	0
Dec	0	0

Source: Compiled from tables 4.4 and 4.6

Information on liabilities (money owed) was more forthcoming than information on liquid cash balances. On average 70 percent of the farmers had borrowed money from their neighbours. There were high variations in money borrowed making the average percent only indicative. However, it is still realistic to assume that an average household in the village owes some cash to a relatively well off neighbour in the tune of T.Shs. 3000. Institutional credit to villagers has been received through the Cooperative Society Branch in the village. About 80 percent of the villagers have received fertilizer, improved seed and pesticides under a credit scheme. Nevertheless, farmers complained bitterly for the inefficient functioning of the cooperative society branch. The main problem mentioned being the bureaucratic procedures involved and harassment in case of default. Also the high interest charged (31 percent) on borrowed money. Local money lending in Mhonda village is mainly based on good neighbourliness, blood ties or friendship.

Consequently, interest is rarely charged for such loans which are usually small. In absence of institutional credit, these are easily accessible and often more flexible to meet cash needs requiring immediate attention. Thus from records at the Cooperative Society Branch, the average institutional credit for the farm household is T.Shs. 150 000 per year. Average total borrowed money by the household is about T.Shs. 153 000 per year. Thus total working capital available for the household is valued at T.Shs. 163 950 of which T.Shs. 8450 is working capital for capital equipment, T.Shs. 3 000 is credit from local money lenders, T.Shs. 2500 is liquid cash balance at start of the year and T.Shs. 150 000 is institutional credit for farming activities. Thus T.Shs. 163 950 is the working capital limit for the farming activities.

Table 4.12 Total monthly labour requirement per hectare for crops under all cropping system in Mhonda village(ME-mandays).

Month	Total labour requirement (ME-mandays)
Jan	113
Feb	117
Mar	137
Apr	106
May	84
Jun	86
Jul	69
Aug	58
Sept	103
Oct	57
Nov	83
Dec	108
TOTAL	998

Source: Compiled from tables 4.9, 4.10 and 4.11

4.1.1.4 Entrepreneurship or management input in farm activities in Mhonda village

Entrepreneurship or ability to plan and organize production activities rationally is one important factor that influences farm productivity. There are a number of variables which can be taken as proxy measures for managerial ability of a peasant farmer. These include education level and literacy, age and experience to work, exposure to new information, motivation to achievement and so forth (Tibaijuka 1984). Thus assuming that age of the farmer is a good indicator of managerial ability in the village it can be asserted that farmers in the age group 25-65 have the experience and strength to manage their farms efficiently. This group makes 83 percent of the sampled farmers. 13 percent of the farmers were above 65 years and getting tired to farm because of age. 7 percent of the farmers were below 25 years and can be considered still young hence rather inexperienced.

Table 4.13. The per hectare total labour supply versus labour demand in adult-equivalent mandays per month in Mhonda village.

Month	Available labour (ME-mandays)	Required labour (ME-mandays)	Difference (ME-mandays)
January	74	113	-39
February	39	117	-78
March	43	137	-94
April	47	106	-59
May	43	84	-41
June	94	86	8
July	98	69	29
August	90	58	32
September	94	103	-9
October	105	57	48
November	82	88	-6
December	51	98	-47
	860	998	

Source: Compiled from tables 4.8 ad 4.12.

Considering education level and literacy in the village as having any bearing on agricultural productivity, survey results indicate that the average level of education is generally low. 93 percent of the heads of households (whom 97 percent are males and only 3 percent are females) were primary school leavers (i.e. 7 years in school), 3 percent were secondary school leavers (i.e. 12 years in school) and 3 percent were illiterate. If Shultz's contention that productivity of peasant agriculture can only be achieved by adopting improved technologies is accepted, it can be concluded that agricultural education will have an important role to play in raising farm productivity in the village, particularly in facilitating adoption of new technologies. The fact that many farmers have primary education lays a firm basic foundation in imparting new agricultural education to villagers which can be integrated with indigenous farm management systems to achieve better results in farm productivity.

Table 4.14 Capital equipment owned per farm household in Mhonda village

Type of tool	# of units	Value (T.Shs./unit)	Total value ⁽¹⁾ (T.Shs.)
Hoe ("jembe")	3	1700	5100
Matchete ("panga")	1	800	800
Axe ("shoka")	1	1350	1350
Bush-knife ("mundu")	1	1200	1200
TOTAL			8450

Source: Own field data

Footnote:(1) T.Shs. 520 = 1 US \$ (average official exchange rate in mid-1994).

4.1.1.5 Household farm output and resource productivity

This section presents survey findings on household farm output in Mhonda village. It also gives estimated resource productivities on the average household farm in the village. The average yield levels (mean outputs) of major crops grown in Mhonda village are presented in table 4.15. Crop production in Mhonda village is diversified mainly for food production. These food crops are mainly produced on seasonal or annual basis except for few fruit trees scattered in farms which are perennial. There is a potential for cash crop production in the area but households have abandoned such crops due to lack of essential inputs needed for raising such crops, lack of market and prohibitively low prices offered by crop authorities or cooperatives (see table 4.17). Only few stems of crops such as coffee, cardamon and cocoa can still be found in some household farms. Thus the little produced by very few households was considered negligible (i.e. less than 5 kg per crop is produced). Consequently survey results did not differentiate between such crops which are considered minor. Among the contents of table 4.15 vegetable weight is given as wet weight. The other crop weights are given for crops in dried condition. There is a slight reduction in yield when crops are mixed or intercropped due to competition for nutrients, space and light.

Survey results in Mhonda village indicate that maize and cassava provide the main staples (over 90 percent of respondents grow these crops). Maize is consumed as "ugali" (stiff porridge or maize meal) whereas cassava is consumed as "bada" (a stiff porridge from cassava flour). Cassava has been widely used in the village due to frequent invasions by red locusts during the end of the 19th century (refer "Time Line Analysis" in appendix 7). Possibly cassava being a famine crop has rescued households during those "bad" harvest years. Cassava production may remain good even in "bad" harvest years due to its ability to withstand harsh weather conditions

mainly drought and even poor soil fertility (Kowal & Kassam 1978). Early in the 1990's the cassava mealy bug (CMB) emerged in Tanzania (Mhonda village being one of the affected areas) and since then it has threatened cassava crop. The pest has spread pretty fast calling for quick measures to rescue the cassava crop. Control of the epidemic has been through the use of a parasite that feeds on the cassava mealy bug. *Epidinococcus lopezi* is an aphid which can feed on the cassava mealy bug pest, thus has been used to control the spread of the pest. Results are positive and promising. The costs involved are high and thus relevant government agencies in the area have been assigned the duty to prevent further spread of the epidemic.

Table 4.15. A summary of average crop yield levels for various cropping systems in Mhonda village.

Type of crop	Crop yield (kg/ha) ¹		
	Monoculture cropping system	Mixed cropping system	Multiple cropping system
Maize (long rain)	1250	910	1100
Maize (short rain)	600	450	-
Beans (long rain)	650	330	970
Beans (short rain)	350	210	-
Cassava	2500	1900	-
Sorghum	920	650	-
Rice	1500	-	-
Banana	-	1200	-
Vegetables	1200	-	-
Fruit	-	350	-
Minor crops	-	50	-

Source: Own field data

Footnote: 1 blank space indicate that crop is not grown under that cropping system.

In table 4.15 cassava dominates in terms of crop turnover per hectare. This is followed by maize. Both being main staples in the village with cassava consumption being highest during "bad" harvest years. Beans lead in the protein-rich legumes and pulses. They are the main source of protein in the area. They form the main relish supplemented by a wide variety of vegetables both cultivated and wild. Few fruits available serve as an important source of vitamins. The official estimates of yield levels for various crops are given in table 4.16 for comparison with local yield levels in table 4.15. Some variation between field data yield levels and official estimates can be

noted. One reason could be that official estimates are aggregates for a large part of the country. Moreover, these estimates are at times based on partly unreliable returns from field officers in various places. Besides, such estimates do not differentiate between different cropping systems.

Table 4.16 Official (government) estimates of crop yield levels for various crops in Morogoro region

Type of crop	Crop yield (kg/ha)
Maize	1 200
Beans	700
Cassava	2 800
Sorghum	900
Rice	1 200
Banana	1 000
Vegetables	10 000
Fruit	2500
Minor crops	-

Source: Marketing Development Bureau (MDB), Dec. 1993 and Morogoro Region Cooperative Union (MRCU), 1994

- Since the aim of this analysis is to maximize net returns from crop production, defined as total value of production less farm operating expenses and food consumption, it is imperative to specify the prices for various crops grown in Mhonda village. Table 4.17 presents the price list for various crops. Three kinds of prices are given: (i) farmgate prices (also referred to as "unofficial", "parallel market" or "local prices" (ii) prices offered by Morogoro Cooperative Union and (iii) producer prices as issued by the Marketing Development Bureau for various administrative regions in Tanzania. Since the Marketing Development Bureau (MDB) is the government agency within the Ministry of Agriculture and Livestock Development, the price list it prepares can be regarded as the official (government) producer price list for agricultural crops.

A wide disparity can be discerned between the prices. In this analysis parallel market producer prices (farmgate prices) and actual yield data from the field survey in Mhonda village were used because almost all farmers in the village sell their crops in parallel markets. This reflect more realistically the economic conditions faced by the villagers under commercialization of food crops which prevails in the area. The old traditional practices of giving away freely some crops such as fruits and vegetables to neighbours and children are replaced by selling everything on the market. Official prices for scheduled crops (i.e. crops marketable through the official channel namely maize, beans, dried cassava and sorghum) are often uniform throughout the administrative

region. Local prices are determined by demand and supply levels and are often higher than the official price. Poor distribution of crops necessitates higher price and parallel marketing.

Table 4.17. Price list for various crops grown in Mhonda village

Type of crop	(1) Parallel market producer prices (T.Shs./kg)	(2) Official (government) prices (T.Shs./kg)	(3) Morogoro Region Cooperative Union (MRCU) prices (T.Shs./kg)
Maize	93	57	35
Beans	180	158	55
Cassava	70	58	6
Sorghum	73	61	8
Rice	145	87	50
Banana	60	50	30
Tomato	150	139	-
Onion	200	182	-
Cabbage	130	114	-
Coconut	125	123	106
Cowpea	150	133	10
Fruit	145	130	84

- Sources: (1) Own field survey in Mhonda Village, 1993/1994
- (2) Marketing Development Bureau, Dec. 1993
- (3) Morogoro Region Cooperative Union, June 1994

4.1.1.6 Summary of per hectare resources availability, utilization and productivity for a household farm in Mhonda village

Gross returns and margins for a peasant farm household in Mhonda village

An economic analysis of any business involves relating the level of output to costs or quantities of resources used to produce them. In farm analysis, gross returns and gross margins are often used as a proxy to measure the relative profitability of putting a given parcel of land under a particular crop. This is particularly important in an environment of land scarcity and high population pressure to the extent that the opportunity cost of land is quite high or keeps rising (Mlambiti 1985).

Table 4.18. Calculation of gross return and margins (T.Shs. in 1994 prices) for the major crops grown under monoculture cropping system in a peasant household farm in Mhonda village (T.Shs.).

Item	Crops under monoculture cropping system							
	MSRU	MLRU	BSRU	BLRU	C ¹	R	S	V
REVENUE:								
Yield(kgha-1)	600	1250	350	650	2500	1500	920	1200
Price (T.Shs.kg ⁻¹)	93	93	180	180	70	145	73	200
Gross returns(T.Shs.ha ⁻¹)	55800	116250	63000	117000	175000	217500	67160	240000
COSTS:								
1.Seed (kgha⁻¹)								
Unit cost (T.Shs.kg ⁻¹)	25	25	80	80	0	100	50	10
Total cost (T.Shs.ha ⁻¹)	360	360	310	310	0	350	315	315
2.Fertilizer								
2.1SA² (kgha⁻¹)								
Unit cost (T.Shs.kg ⁻¹)	22.5	22.5	0	0	0	100	20	150
Total cost (T.Shs.ha ⁻¹)	120	120	0	0	0	120	120	120
2.2TSP³ (kgha⁻¹)								
Unit cost (T.Shs.kg ⁻¹)	15	15	20	20	0	50	20	50
Total cost (T.Shs.ha ⁻¹)	160	160	160	160	0	160	160	160
3.Manure (kgha⁻¹)								
Unit cost (T.Shs.kg ⁻¹)	0	0	2000	2000	0	0	0	5000
Total cost (T.Shs.ha ⁻¹)	0	0	2	2	0	0	0	2
4.Handtools (T.Shs.)								
Total cost (T.Shs.ha ⁻¹)	0	0	4000	4000	0	0	0	10000
5.Chemicals (T.Shs.)								
Total cost (T.Shs.ha ⁻¹)	8450	8450	8450	8450	8450	8450	8450	47170
GRAND TOTAL COST (T.Shs.)								
(1+2+.....+5)	0	0	0	0	0	0	0	15000
GRAND TOTAL COST (T.Shs.)	22550	22550	40450	40450	8450	63450	29800	101320
GROSS MARGIN⁴(T.Shs.ha-1)								
(GR-GTC)	33250	93700	22550	76550	166550	154050	37360	138680

Source: Own field data

Footnotes: 1 Cassava crop is raised from stem cuttings which are often obtained freely from neighbours or relatives or from previous year's crop. No seed is used to raise cassava.

2 SA = Sulphate of ammonia.

3 TSP = Triple super phosphate.

4 Gross margin = Gross returns less total input costs (i.e.total farm expenses).

Gross returns for a crop can be computed by multiplying gross output of the crop times its price whereas gross margin equals gross returns less total farm expenses (i.e. total input costs). Total farm expenses calculation involve valuating farm produced inputs such as seed and manure as well as purchased inputs mainly fertilizer, chemicals and hand tools. As in most other semi-subsistence production systems farm expenses in terms of purchased inputs are negligible (Tibaijuka 1984). However, since the farming system embraces some perennial crops some capital is tied up in the farms. Therefore it becomes important to study the returns to invested capital in addition to other factors of production.

Table 4.19. Calculation of gross return and margins (T.Shs. in 1994 prices) for the major crops grown under mixed cropping system in a peasant household farm in Mhonda village

Item	Crops under mixed cropping system								
	SRM	SRB	LRM	LRB	M	S	C ¹	B	M
REVENUE:									
Yield (kg/ha-1)	450	210	1100	470	930	750	2300	200	700
Price (T.Shs.kg ⁻¹)	93	180	93	180	93	73	70	180	93
Gross returns(T.Shs.ha ⁻¹)	41850	37800	102300	84600	86490	54750	161000	36000	65100
COSTS:									
1.Seed (kg/ha ⁻¹)	12.5	40	12.5	40	12.5	25	0	40	12.5
Unit cost (T.Shs.kg ⁻¹)	360	310	360	310	360	315	0	310	360
Total cost (T.Shs.ha ⁻¹)	4500	12400	4500	12400	4500	7875	0	12400	4500
2.Fertilizer									
2.1SA ² (kg/ha ⁻¹)	11.3	11.3	11.3	11.3	10	10	0	0	5.6
Unit cost (T.Shs.kg ⁻¹)	120	120	120	120	120	120	0	0	120
Total cost (T.Shs.ha ⁻¹)	1356	1356	1356	1356	1200	1200	0	0	672
2.2TSP ³ (kg/ha ⁻¹)	7.5	10	7.5	10	8.5	10	0	5	3.8
Unit cost (T.Shs.kg ⁻¹)	160	160	160	160	160	160	0	160	160
Total cost (T.Shs.ha ⁻¹)	1200	1600	1200	1600	1360	1600	0	800	608
3.Manure (kg/ha ⁻¹)	1000	1000	1000	1000	0	0	0	0	2000
Unit cost (T.Shs.kg ⁻¹)	2	2	2	2	0	0	0	0	2
Total cost (T.Shs.ha ⁻¹)	2000	2000	2000	2000	0	0	0	0	4000
4.Handtools (T.Shs.)	4225	4225	4225	4225	4225	4225	4225	4225	2113
5.Chemicals (T.Shs.)	0	0	0	0	0	0	0	0	0
GRAND TOTAL COST (T.Shs.) (1+2+.....+5)	13281	21581	13281	21581	11285	14900	4225	17425	11893
GROSS MARGIN⁴(T.Shs.ha⁻¹) (GR-GTC)	28569	16219	89019	63019	75205	39850	156775	18575	53207

Source: Own field data

Footnotes: 1 Cassava crop is raised from stem cuttings which are often obtained freely from neighbours or relatives or from previous year's crop. No seed is used.

2 SA = Sulphate of ammonia.

3 TSP = Triple super phosphate.

4 Gross margin = Gross returns less total input costs (i.e. total farm expenses).

Since variable costs are the only costs that are considered as total costs, the gross margin is therefore equal to the net farm income (NFI). Moreover, if the borrowed working capital on the average farm is small, the net income also represents the net farm earnings (i.e. it shows the total income earned by the household from farming).

Table 4.20. Calculation of gross return and margins (T.Shs. in 1994 prices) for the major crops grown under mixed cropping system in a peasant household farm in Mhonda village.

Item	Crops under mixed cropping system (continued)							
	B	C	S	Ba	C	FR	C	Mc
REVENUE:								
Yield (kg/ha-1)	310	1800	550	1200	2000	350	1600	50
Price (T.Shs.kg ⁻¹)	180	70	73	60	70	145	70	158
Gross returns(T.Shs.ha ⁻¹)	55800	126000	40150	72000	140000	50750	112000	7900
COSTS:								
1.Seed (kg/ha⁻¹)	40	0	25	0	0	0	0	5
Unit cost (T.Shs.kg ⁻¹)	310	0	315	0	0	0	0	250
Total cost (T.Shs.ha ⁻¹)	12400	0	7875	0	0	0	0	1250
2.Fertilizer								
2.1SA² (kg/ha⁻¹)	5.6	5.6	5.6	0	0	0	0	0
Unit cost (T.Shs.kg ⁻¹)	120	120	120	0	0	0	0	0
Total cost (T.Shs.ha ⁻¹)	672	672	672	0	0	0	0	0
2.2TSP³ (kg/ha⁻¹)	3.8	0	5	0	0	0	0	0
Unit cost (T.Shs.kg ⁻¹)	160	0	160	0	0	0	0	0
Total cost (T.Shs.ha ⁻¹)	608	0	800	0	0	0	0	0
3.Manure (kg/ha⁻¹)	1000	0	0	3000	0	2000	0	0
Unit cost (T.Shs.kg ⁻¹)	2	0	0	2	0	2	0	0
Total cost (T.Shs.ha ⁻¹)	2000	0	0	6000	0	4000	0	0
4.Handtools (T.Shs.)	2113	2113	2113	4225	4225	4225	4225	4225
5.Chemicals (T.Shs.)	0	0	0	0	0	0	0	0
GRAND TOTAL COST (T.Shs.) (1+2+.....+5)	17793	2785	11460	10225	4225	8225	4225	5475
GROSS MARGIN⁴(T.Shs.ha⁻¹) (GR-GTC)	38007	123215	28690	61775	135775	42525	107775	2425

Source: Own field data

Footnotes: 1 Cassava crop is raised from stem cuttings which are often obtained freely from neighbours or relatives or from previous year's crop. No seed is used.

2 SA = Sulphate of ammonia.

3 TSP = Triple super phosphate.

4 Gross margin = Gross returns less total input costs (i.e.total farm expenses).

Thus in this study, gross returns and margins for the peasant household farms in Mhonda village were computed to determine the total gross income of the peasant farm and relative contribution or profitability made by the major crops grown in the household farm. The gross returns and margins for various crops under different cropping systems are presented in tables 4.18, 4.19, 4.20 and 4.21. The gross returns and margins indicate the allocation of resources to the various enterprises and specific activities. This shows also the direction of resources productivity. However, more concrete conclusions in this regard will be made from returns to factors of production. From the gross margins it can be noted that peasant farmers in Mhonda village have gross margins comparable to Tanzania's minimum salary of T.Shs. 10 000 per month for government employees (as at mid-1994). The fact that food prices are at least 3 to 4 times higher in urban areas may lead to the fact that the real value of a minimum salary drops correspondingly. Thus the average peasant farmer in Mhonda village may be getting higher net farm income than a labourer in urban centres. A similar situation was observed in Bukoba Tanzania by Friedrich (1968) in 1964/65. Of course there are variations in actual farm sizes between farmers in the village and therefore the distribution of net farm income varies accordingly. Generally it can be expected that gross margin declines proportionally with total farm size. Moreover, farmer's earnings are not evenly distributed over the year and in consequence there are periods when farmer's cash balances are very low to the detriment of their welfare.

Table 4.21 Calculation of gross return and margins (T.Shs. in 1994 prices) for the major crops grown under multiple cropping system in a peasant household farm in Mhonda village

Item	Crops under multiple cropping system		
	Maize (M)	Beans (B)	Beans (B)
REVENUE:			
Yield (kgha ⁻¹)	1100	470	500
Price (T.Shs.kg ⁻¹)	93	180	180
Gross returns(T.Shs.ha ⁻¹)	102300	84600	90000
COSTS:			
1.Seed (kgha⁻¹)			
Unit cost (T.Shs.kg ⁻¹)	12.5	40	80
Total cost (T.Shs.ha ⁻¹)	360	310	310
	4500	12400	24800
2.Fertilizer			
2.1SA² (kgha⁻¹)			
Unit cost (T.Shs.kg ⁻¹)	11.3	11.3	0
Total cost (T.Shs.ha ⁻¹)	120	120	0
	1356	1356	0
2.2TSP³ (kgha⁻¹)			
Unit cost (T.Shs.kg ⁻¹)	7.5	10	20
Total cost (T.Shs.ha ⁻¹)	160	160	160
	1200	1600	3200
3.Manure (kgha⁻¹)			
Unit cost (T.Shs.kg ⁻¹)	2000	1000	1000
Total cost (T.Shs.ha ⁻¹)	2	2	2
	4000	2000	2000
4.Handtools (T.Shs.)			
	4225	4225	8450
5.Chemicals (T.Shs.)			
	0	0	0
GRAND TOTAL COST (T.Shs.) (1+2+.....+5)	15281	21581	38450
GROSS MARGIN⁴(T.Shs.ha⁻¹) (GR-GTC)	87019	63019	51550

Source: Own field data

Footnotes: 1 Cassava crop is raised from stem cuttings which are often obtained freely from neighbours or relatives or from previous year's crop. No seed is used.

2 SA = Sulphate of ammonia.

3 TSP = Triple super phosphate.

4 Gross margin = Gross returns less total input costs (i.e.total farm expenses).

Returns to factors of production

Besides the gross returns and gross margins presented in tables 4.18, 4.19, 4.20 and 4.21 the relative returns to factors of production were also computed. This involved examining input resources utilized per unit of output. The basic premise was that all factors of production (i.e. land labour and capital) are limiting and must therefore be utilized in the best possible manner.

Table 4.22 Summary of resources availability, utilization and productivity per hectare for crops under monoculture cropping system for a typical household farm in Mhonda village.

Item	Crops under monoculture cropping system							
	MSRU ¹	MLRU ¹	BSRU ¹	BLRU ¹	C	R	S	V
Land area (ha):	0.10	0.13	0.10	0.10	0.18	0.14	0.10	0.10
Household labour (ME-mandays):								
January	7	9	4	7	11	13	2	6
February	9	11	8	7	12	15	4	7
March	0	13	0	10	13	17	9	12
April	0	12	0	13	10	14	6	11
May	0	10	0	14	8	12	2	8
June	0	5	0	7	8	14	7	10
July	0	2	0	2	4	10	6	4
August	0	3	0	9	10	6	3	2
September	5	4	9	3	16	9	4	14
October	4	0	5	0	12	0	0	3
November	12	0	16	0	15	0	0	13
December	14	0	12	0	22	8	0	9
Fertilizer nutrients(kg):								
Nitrogen	22.5	22.5	0	0	0	100	20	150
Phosphorus	15	15	20	20	0	50	20	50
Farmyard manure (t):	0	0	2000	2000	0	0	0	5000
Working capital ¹ (T.Shs):	17450	17450	33250	33250	8450	43450	24200	65320
Total cost of crop production (T.Shs.):	22550	22550	40450	40450	8450	63450	29800	101320
Crop yield (kg):	600	1250	350	650	2500	1500	920	1200
Crop price (T.Shs.):	93	93	180	180	70	145	73	200
Gross returns (T.Shs.):	55800	116250	63000	117000	175000	217500	67160	240000
Gross margin ² (T.Shs.):	33250	93700	22550	76550	166550	154050	37360	138680

Source: Own field survey data and tables 4.9, 4.10, 4.11, 4.18, 4.19, 4.20 and 4.21

Footnotes:1 Working capital refers to cash allocated for purchase of seed/seedlings, chemicals and hand tools.

2 Gross margin is obtained by deducting total cost of crop production from gross returns.

3 Yield and price are not included in this table because each category has several crops. However this information is contained in tables 4.18 through 4.21.

Land returns per hectare were computed by dividing total gross margin by cultivated area for each crop. Returns to labour were computed as net farm income (total gross margin) divided by family labour input for each crop (disregarding tractors, draught animals or other sources of power which are not used). Labour input equals total number of mandays per hectare per year.

Table 4.23 Summary of resources availability, utilization and productivity per hectare for crops under mixed cropping system for a typical household farm in Mhonda village.

Item	Crops under mixed ¹ cropping system							
	SRM/B	I.RM/B	M/S	C/B	M/B/C/S	Ba/C	FR/C	Mc
Land area (ha):	0.10	0.20	0.10	0.12	0.25	0.14	0.14	0.1
Household labour (ME-mandays):								
January	4	6	4	6	8	10	7	3
February	5	7	3	4	5	6	4	2
March	0	13	10	7	12	5	5	4
April	0	9	7	6	7	2	0	2
May	0	6	5	2	5	2	0	1
June	0	6	4	2	7	2	1	1
July	0	5	7	3	8	3	2	2
August	0	3	4	4	3	2	3	1
September	4	2	3	8	4	5	8	5
October	4	0	0	9	6	8	6	0
November	11	0	0	0	0	9	10	2
December	10	0	0	0	0	7	12	4
Fertilizer nutrients(kg):								
Nitrogen	22.5	22.5	20	0	22.5	0	0	0
Phosphorus	15	15	17	0	15	0	0	0
Farmyard manure (t):	2	2	0	0	3	3	2	0
Working capital ¹ (T.Shs.):	25350	25350	20825	20850	20838	18450	18450	9700
Total cost of crop production (T.Shs.):	34862	34862	26185	21650	43931	14450	12450	5475
Gross returns (T.Shs.):	79650	186900	141240	197000	287050	212000	162750	7900
Gross margin ² (T.Shs.):	44788	152038	115055	175350	243119	197550	150300	2425

Source: Own field survey data and tables 4.9, 4.10, 4.11, 4.18, 4.19, 4.20 and 4.21

Footnotes:1 Working capital refers to cash allocated for purchase of seed/seedlings, chemicals and hand tools.

2 Gross margin is obtained by deducting total cost of crop production from gross returns.

3 Yield and price are not included in this table because each category has several crops. However this information is contained in tables 4.18 through 4.21.

Returns to capital were calculated by deducting the value of family labour from net farm income. Family labour is - rather theoretically - valued at the Tanzania's 1994 prevailing minimum wage rate of T.Shs. 357 per 8 hour labour day. This is based on the assumption that all farm labour can find alternative employment in urban centres (towns) at the ongoing wage rate.

Table 4.24 Summary of resources availability, utilization and productivity per hectare for crops under multiple cropping system for a typical household farm in Mhonda village.

Item	Crops under multiple cropping system	
	Maize/Bean (M/B)	Beans (B)
Land area (ha):	0.20	0.20
Household labour (ME-mandays):		
January	6	0
February	8	0
March	7	0
April	0	7
May	0	9
June	5	7
July	6	5
August	3	2
September	0	0
October	0	0
November	0	0
December	0	0
Fertilizer nutrients(kg):		
Nitrogen	22.5	0
Phosphorus	15	20
Farmyard manure (t):	3	2
Working capital ¹ (T.Shs):	25350	33250
Total cost of crop production (T.Shs.):	36862	38450
Gross returns (T.Shs.):	186900	90000
Gross margin ² (T.Shs.):	150038	51550

Source: Own field survey data and tables 4.9, 4.10, 4.11, 4.18, 4.19, 4.20 and 4.21

Footnotes: 1 Working capital refers to cash allocated for purchase of seed/seedlings, chemicals and hand tools.

2 Gross margin is obtained by deducting total cost of crop production from gross returns.

3 Yield and price are not included in this table because one category has several crops. However this information is contained in tables 4.18 through 4.21.

According to Low (1986) in his application of household economic theory in Southern Africa, this is an unrealistic assumption because labour market wage rates might vary among persons in the same household due to comparative advantage in the labour market. However, for the purpose of comparison, it is a usual practice to value farming labour at the prevailing minimum wage rate (Tibaijuka 1984).

Land returns per hectare were computed by dividing total gross margin by cultivated area for each crop. Returns to labour were computed as net farm income (total gross margin) divided by family labour input for each crop (disregarding tractors, draught animals or other sources of power which are not used). Labour input equals total number of mandays per hectare per year.

Table 4.23 Summary of resources availability, utilization and productivity per hectare for crops under mixed cropping system for a typical household farm in Mhonda village.

Item	Crops under mixed ¹ cropping system							
	SRM/B	LRM/B	M/S	C/B	M/B/C/S	Ba/C	FR/C	Mc
Land area (ha):	0.10	0.20	0.10	0.12	0.25	0.14	0.14	0.1
Household labour (ME-mandays):								
January	4	6	4	6	8	10	7	3
February	5	7	3	4	5	6	4	2
March	0	13	10	7	12	5	5	4
April	0	9	7	6	7	2	0	2
May	0	6	5	2	5	2	0	1
June	0	6	4	2	7	2	1	1
July	0	5	7	3	8	3	2	2
August	0	3	4	4	3	2	3	1
September	4	2	3	8	4	5	8	5
October	4	0	0	9	6	8	6	0
November	11	0	0	0	0	9	10	2
December	10	0	0	0	0	7	12	4
Fertilizer nutrients(kg):								
Nitrogen	22.5	22.5	20	0	22.5	0	0	0
Phosphorus	15	15	17	0	15	0	0	0
Farmyard manure (t):	2	2	0	0	3	3	2	0
Working capital ¹ (T.Shs.):	25350	25350	20825	20850	20838	18450	18450	9700
Total cost of crop production (T.Shs.):	34862	34862	26185	21650	43931	14450	12450	5475
Gross returns (T.Shs.):	79650	186900	141240	197000	287050	212000	162750	7900
Gross margin ² (T.Shs.):	44788	152038	115055	175350	243119	197550	150300	2425

Source: Own field survey data and tables 4.9, 4.10, 4.11, 4.18, 4.19, 4.20 and 4.21

Footnotes:1 Working capital refers to cash allocated for purchase of seed/seedlings, chemicals and hand tools.

2 Gross margin is obtained by deducting total cost of crop production from gross returns.

3 Yield and price are not included in this table because each category has several crops. However this information is contained in tables 4.18 through 4.21.

Returns to capital were calculated by deducting the value of family labour from net farm income. Family labour is - rather theoretically - valued at the Tanzania's 1994 prevailing minimum wage rate of T.Shs. 357 per 8 hour labour day. This is based on the assumption that all farm labour can find alternative employment in urban centres (towns) at the ongoing wage rate.

Table 4.24 Summary of resources availability, utilization and productivity per hectare for crops under multiple cropping system for a typical household farm in Mhonda village.

Item	Crops under multiple cropping system	
	Maize/Bean (M/B)	Beans (B)
Land area (ha):	0.20	0.20
Household labour (ME- mandays):		
January	6	0
February	8	0
March	7	0
April	0	7
May	0	9
June	5	7
July	6	5
August	3	2
September	0	0
October	0	0
November	0	0
December	0	0
Fertilizer nutrients(kg):		
Nitrogen	22.5	0
Phosphorus	15	20
Farmyard manure (t):	3	2
Working capital ¹ (T.Shs):	25350	33250
Total cost of crop production (T.Shs.):	36862	38450
Gross returns (T.Shs.):	186900	90000
Gross margin ² (T.Shs.):	150038	51550

Source: Own field survey data and tables 4.9, 4.10, 4.11, 4.18, 4.19, 4.20 and 4.21

Footnotes:1 Working capital refers to cash allocated for purchase of seed/seedlings, chemicals and hand tools.

2 Gross margin is obtained by deducting total cost of crop production from gross returns.

3 Yield and price are not included in this table because one category has several crops. However this information is contained in tables 4.18 through 4.21.

According to Low (1986) in his application of household economic theory in Southern Africa, this is an unrealistic assumption because labour market wage rates might vary among persons in the same household due to comparative advantage in the labour market. However, for the purpose of comparison, it is a usual practice to value farming labour at the prevailing minimum wage rate (Tibaijuka 1984).

Table 4.25 Calculation of returns to factors of production for crops under monoculture cropping system in a household farm in Mhonda village.

Items	Crops under monoculture cropping system							
	MSRU'	MLRU'	BSRU'	BLRU'	C	R	S	V
Gross margin (T.Shs.ha ⁻¹)	33250	93700	22550	76550	166550	154050	37360	138680
Labour input (ME-mandays/ha)	51	69	54	72	141	118	43	99
Returns to labour ¹ (T.Shs.ME-manday ⁻¹)	652	1358	418	1064	1182	1306	869	1400
Cultivated area per crop (ha)	0.10	0.13	0.10	0.10	0.18	0.14	0.10	0.10
Returns to land ² (T.Shs.ha ⁻¹)	333500	720770	225500	765500	925278	1100358	373600	1386800
Value of family labour ³ (VFL)(T.Shs.ha ⁻¹)	18207	24633	19278	25704	50337	42126	15351	35343
Gross margin less VFL (T.Shs.ha ⁻¹)	15043	69067	3272	50846	116213	111924	22009	103337
Returns to capital ⁴ (%)	3.2	14.9	0.7	11.0	25.1	24.1	4.7	22.3

Source: Compiled from tables 4.18, 4.19, 4.20, 4.21, 4.22, 4.23, 4.24.

- Footnotes: 1 Returns to labour equals gross margin divided by labour input.
 2 Returns to land equals gross margin divided by cultivated area.
 3 Value of family labour (VFL) equals ME mandays per hectare times Tanzania's prevailing minimum wage rate of T.Shs. 357 per 8-hour labour day.
 4 Returns to capital equals gross margin less value of family labour expressed as a percentage of the total farm capital (equity + working capital) valued at T.Shs. 463 950).

The resulting margin is expressed as a percentage of the total farm capital (equity plus working capital) which in Mhonda village amounted to an average of T.Shs. 463 950 per household per year. A negative return on capital in column 9 of table 4.26 indicate that the farmer was not able to cover his labour costs at the running minimum wage rate of T.Shs. 357 per 8 hour labour day. The reason may be that prices offered for minor crops are too low to cover the costs of production for these crops. The results showing returns to all factors of production are presented in tables 4.25, 4.26 and 4.27. Regarding resource productivity mixed cropping system shows the highest returns to factors of production hence is the most profitable cropping system. These returns could be even higher if higher crop prices were offered. In other words, the present yields

and prices are still too low and on account of toilsome and irksome nature of farmwork, these low producer prices do not justify foregoing paid employment if one could be found. No wonder therefore younger men prefer looking for wage labour or engaging in petty trading than producing annual crops for sale.

Table 4.26 Calculation of returns to factors of production for crops under mixed cropping system in Mhonda village.

Item	Crops under mixed cropping system							
	SRM/B	LRM/B	M/S	C/B	M/B/C/S	Ba/C	FR/C	Mc
Gross margin (T.Shs.ha ⁻¹)	44788	152038	115055	175350	243119	197550	150300	2425
Labour input (ME-mandays/ha)	38	57	47	51	65	61	58	27
Returns to labour ¹ (T.Shs.ME-manday ⁻¹)	1179	2668	2448	3439	3741	3239	2592	90
Cultivated area per crop (ha)	0.10	0.20	0.10	0.12	0.25	0.14	0.14	0.10
Returns to land ² (T.Shs.ha ⁻¹)	447880	760190	1150550	1461250	972476	1411072	1073571	24250
Value of family labour ³ (VFL)(T.Shs.ha ⁻¹)	13566	20349	16779	18207	23205	21777	20706	9639
Gross margin less VFL (T.Shs.ha ⁻¹)	31222	131689	98276	157143	219914	175773	129594	-7214
Returns to capital ⁴ (%)	6.7	28.4	21.2	33.9	47.4	37.9	27.9	-1.6

Source: Source: Compiled from tables 4.18, 4.19, 4.20, 4.21, 4.22, 4.23, 4.24.

- Footnotes: 1 Returns to labour equals gross margin divided by labour input.
 2 Returns to land equals gross margin divided by cultivated area.
 3 Value of family labour (VFL) equals ME mandays per hectare times Tanzania's prevailing minimum wage rate of T.Shs. 357 per 8-hour labour day.
 4 Returns to capital equals gross margin less value of family labour expressed as a percentage of the total farm capital (equity + working capital) valued at T.Shs. 463 950).

Tables 4.22, 4.23 and 4.24 present a summary of resources availability, utilization and productivity for a typical household farm in Mhonda village. The resources are differentiated by cropping systems. The entries in these tables form the basis for the detached coefficient matrix (Appendix 5) and the data input file (Appendix 6) for the compromise programming model developed in this study.

Table 4.27 Calculation of returns to factors of production for crops under multiple cropping system in Mhonda village.

Item	Crops under multiple cropping system	
	Maize/Beans (M/B)	Beans (B)
Gross margin (T.Shs.ha ⁻¹)	150038	51550
Labour input (ME-mandays/ha)	35	30
Returns to labour ¹ (T.Shs.ME-manday ⁻¹)	4287	1719
Cultivated area per crop (ha)	0.20	0.20
Returns to land ² (T.Shs.ha ⁻¹)	750190	257750
Value of family labour ³ (VFL)(T.Shs.ha ⁻¹)	12495	10710
Gross margin less VFL (T.Shs.ha ⁻¹)	137543	40840
Returns to capital ⁴ (%)	29.7	8.8

Source: Compiled from tables 4.18, 4.19, 4.20, 4.21, 4.22, 4.23, 4.24.

- Footnotes: 1 Returns to labour equals gross margin divided by labour input.
 2 Returns to land equals gross margin divided by cultivated area.
 3 Value of family labour (VFL) equals ME mandays per hectare times Tanzania's prevailing minimum wage rate of T.Shs. 357 per 8-hour labour day.
 4 Returns to capital equals gross margin less value of family labour expressed as a percentage of the total farm capital (equity + working capital) valued at T.Shs. 463 950).

4.1.1.7 Concluding remarks on micro-economic analysis

The analysis of input resource productivity have shown that mixed cropping is a more profitable cropping system among the cropping systems practiced in Mhonda village. It generates the highest gross margin particularly in the M/B/C/S mixture (T.Shs. 43931 per year). The same mixed cropping system gives highest returns to the factors of production (land, labour and capital). Thus although over the course of time farmers have identified and adopted what they consider to be appropriate and profitable enterprises, they can still benefit even more by concentrating on enterprises identified in this micro-economic analysis as yielding highest returns.

However, the micro-economic analysis conducted here does not identify the optimal use of scarce resources which must accompany farmer's concentration in high returns cropping patterns. For example it does not tell how much land to allocate to a particular crop. Neither does it say anything about the sustainability of the system in terms of meeting consumption needs as a result of growing population, ecological degradation and deforestation, risks and labour requirements over time of the year. This information is vital and important for the farmers to make the best use of their scarce resources. Thus these issues form the subject matter of the next section.

4.2 Model analysis results and discussions

4.2.1 Results of the basic model

4.2.1.1 Pay-off matrix and ideal farm plan of an average household in Mhonda village

The pay-off matrix for the three objectives in the basic model is presented in table 4.28. The pay-off matrix was obtained by optimizing a single objective under consideration and computing corresponding values of the other objectives. Reading the elements across columns in the table gives the values of the three objectives when only one, indicated by the row heading, was optimized. The elements in the main diagonal of the matrix represent the ideal cropping (farm) plan at which all the objectives achieve their optimum value. The ideal cropping plan yielded T.Shs. 282800 at a risk level of T.Shs. 112934 and labour use variation of 3.4 ME-mandays. However, this plan is often infeasible (unattainable) because the objectives are in conflict. Information about the conflicting nature of the objectives can be gleaned from the pay-off matrix. A least level of risk can only be attained with an allowance of high labour use variation and reduced income. Similarly the highest income is only possible when labour use variation is high. This conflict of objectives is true for any pair among the objectives although there may be few cases where some objectives may be complementary (Zekri and Romero 1992 & 1993).

The conclusions from the pay-off matrix are that when risk is minimized, income and labour achieve their worst value. There is also a marked degree of conflict between current situation in the farming systems in Mhonda village and the objective of seasonal labour. However, only a modest degree of conflict exist between the current situation in the farming systems in Mhonda village and total net income implying that total net income can be considered to be a good surrogate of the unknown preferences of Mhonda village farmers.

Table 4.28 Pay-off matrix and ideal point for the optimal farm plan of an average household in Mhonda village.

	Maximization of total net income (T.Shs.)	Minimization of SDI (T.Shs.)	Minimization of SDL (ME-mandays)
Maximization of total net income	282800	195590	4.43
Minimization of SDI*	150060	112934	6.20
Minimization of SDL**	201000	197348	3.42

Source: Model results

Footnotes:

* SDI Standard deviation of income

** SDL Standard deviation of labour use

In light of the conflicting nature of the objectives being modelled in this study, a trade-off has to be made. Thus to minimize risk the farmer must accept a lower net cash income than the ideal point. Consequently a farmer would accept a plan with higher income variance only if it is coupled with an increase in the expected net cash income such that this compensation must increase at an increasing rate with increase in income variance (Hazell 1971). In practice the farmer will find a compromise solution set which is as close as possible to the ideal point. Multi-objective programming is often used for this purpose ((Prem, Prihar & Cheema 1988; Siskos, Despotis & Ghediri 1994). In this study a number of solution points, the Pareto optimal or non-dominated points, were developed as a way of increasing the range of choices. These points were generated by minimizing different distance concepts ranging from 1 to ∞ . These compromise farm plans for the three objectives at L_1 , L_2 and L_∞ metrics form the subject of the next section.

4.2.1.2 Compromise farm plan for an average household in Mhonda village

The compromise farm (cropping) plans for an average household in Mhonda village as obtained from the basic model are presented in table 4.29. Three types of compromise farm plans, CP_{L_j} , where, $L = 1, 2$ and ∞ were developed, depending on the different parameters of L . These were compared with the existing production plan. Sensitivity analysis was later conducted by using different weights assigned to the three objectives in reflection of the farmer's preferences. The results of sensitivity analysis are presented section 4.2.2.8. The discussion of the generated compromise farm plans follows in the next section.

Table 4.29 Compromise farm plans and the existing farm plan for an average household in Mhonda village

Level of variable/objective function value ¹	Existing farm plan	Optimal Compromise farm plans		
		L ₁	L ₂	L _m
Max income(T.Shs./year)	233750	282800	282800	266310
Min SDI (T.Shs.)	168321	195590	195590	175968
Min SDL (ME-mandays)	3.45	3.45	3.45	3.45
Land allocation (ha) ² :				
Monocropping				
MSRU	0.100	0	0	0
MLRU	0.130	0	0	0
BSRU	0.100	0	0	0
BLRU	0.100	0.025	0.025	0
Cassava	0.180	0	0	0
Rice	0.140	0.087	0.087	0.209
Sorghum	0.100	0	0	0
Vegetable	0.100	0.500	0.500	0.500
Mixed cropping				
SRM/B	0.100	0	0	0
LRM/B	0.200	0.261	0.261	0.600
Maize/Sorghum	0.100	0.031	0.031	0.068
Cassava/Beans	0.120	0.809	0.809	0.546
M/B/C/S	0.250	0.083	0.083	0.033
Banana/Cassava	0.140	0.090	0.090	0.090
Fruit/Cassava	0.140	0.131	0.131	0.131
Minor crops	0.100	0.100	0.100	0.100
Multiple cropping				
Maize/Beans	0.200	0.382	0.382	0.223
Beans	0.200	0	0	0
Total cultivated land	2.5	2.5	2.5	2.5
Fertilizer nutr.(kg):				
Nitrogen	55	101	101	117
Phosphorus	38	41	41	50
Working capit. (T.Shs.)	61106	77887	77887	81145
Food consumption (kg):				
Maize	794	794	794	794
Beans	506	506	506	506
Cassava	654	2402	2402	1706
Rice	131	131	131	314
Sorghum	69	69	69	69
Vegetable	600	600	600	600
Banana	108	108	108	108
Fruit	46	46	46	46
Minor crops	5	5	5	5

Source: Model results and own field data

Footnote: (1) Symbols remain as defined earlier

(2) Land allocation is given in three decimal places because truncating to one decimal place would over-estimate the size of land area under each crop

4.2.1.3 Analysis of the solution: Comparison of the existing and compromise farm plans

Objective function values

Looking at the objective function values (table 4.29) for the compromise farm plans corresponding to the metrics (i.e. concepts of distance between the ideal value and compromise solution) L_1 , L_2 and L_∞ , the trade-off between them can be gleaned. The farmer can choose any of them based on his subjective preferences. Also by comparing the three compromise farm plans against the existing farm plan the difference between them can be gleaned. In terms of income, all compromise farm plans were superior to the existing farm plan since the former gave higher income than the latter. The increase in income compared to that obtained in the existing farm plan were 21%, 21% and 14% for the L_1 , L_2 and L_∞ metrics respectively. Thus there is a possibility of gaining, through welfare maximization, if the farmer adopts any of the compromise farm plans to replace the existing farm plan. Through selection of only those enterprises which are profitable the model has made sure that higher total net income is realized than in the existing farm plan. This would be beneficial to the farmer.

As expected, the compromise farm plans are superior to the existing farm plan in terms of levels of risk as a percentage of income. The values are 72% for the existing farm plan and 69%, 69% and 66% for the compromise farm plans corresponding to the L_1 , L_2 and L_∞ metrics respectively. However, the absolute level of risk (T.Shs. 168321) for the existing farm plan was lower compared to the compromise farm plans for which the risk levels were T.Shs. 195590, 195590 and 175968 corresponding to L_1 , L_2 and L_∞ metrics respectively. This lower level of risk in the existing farm plan compared to the compromise farm plans portrays the real life experience, which is also reported by Kaoneka (1993), that peasant farmers are risk averters. It also suggests that probably more weight is given to risk minimization in the real farming situation than was given in the model. However, farmers will pursue farming even when it is risky, for the sake of meeting subsistence needs and when the expected income increases. Since they rely solely on farming activities for subsistence and cash income, they have limited options. In most cases they tend to be more concerned with the management or avoidance of risk. Holden (1991) reports that in Northern Zambia, peasants planted large areas even before they were guaranteed to get vital fertilizer for their maize crop. In the absence of this fertilizer, harvests were badly affected. Risk factors which affect peasant farmers have been reviewed in earlier sections. The level of labour use variation also reflect the fact that labour use over the year is not uniform due to the skewed labour demand by season. Between any months in the year there is some variation in the level of labour used in farming activities which are influenced by seasons of the year. However, it must be appreciated that a real decision situation that a farmer faces is more complex to be fully simulated by this model. For example, minimum food consumption considered in the model may change given the changing demand for food. Also, for the objective of income maximization, markets may play a decisive role, which means that these changes in income, risk and labour use variation as suggested by the model, may depend very much on the relationship of farmers with the market situation and economic conditions in general. Moreover, ecological and climatic conditions may have a decisive influence on agricultural growth through increased production.

Land allocation, cropping pattern, fertilizer use and food consumption

Comparing the four plans (table 4.29) it can be observed that differences exist in crop production pattern between the existing farm plan and the compromise farm plans. Generally the existing production plan shows a wider diversity of crop production than the compromise farm plans. While there are 18 crop enterprises in the existing farm plan, they are reduced to 11, 11 and 10 crop enterprises in the compromise farm plans for L_1 , L_2 and L_∞ metrics respectively. The reason is that only profitable crop enterprises are selected in the compromise farm plans. The relatively narrow diversity of crop production enterprises in the compromise farm plans (when compared with the existing farm plan) implies that to maximize cash incomes farmers must specialize in profitable enterprises. The compromise farm plans show that some cropping patterns (i.e. those with zero land allocation in table 4.29) should be eliminated. These are mainly the areas under monoculture and multiple cropping which for peasant agriculture, seem uncompetitive for risk aversion and flexibility. On the other hand, the proportion of others, mainly the areas under mixed cropping such as the cassava/beans mixture and maize/beans mixture should be expanded. The land allocated to the main staples (i.e. maize, cassava, sorghum, beans and vegetable) should be expanded at the expense of other crops of less profitability essentially because of scarcity of expansion land for the household. Under conditions of land scarcity, producing mixed crops is more competitive than monocropping. These results are expected and confirm a theoretical expectation that intensification is necessary and efficient under conditions of land scarcity while extensive production is efficient when land is abundant. The elimination of crops under monoculture cropping concurs with peasant farmers inclination towards mixed cropping in their bid for diversification to meet subsistence needs, to avert risks in farming and to ensure flexibility.

The compromise farm plans generated are able to meet FAO/WHO (1973) recommended minimum consumption needs for each crop in the model and some surplus is available for sale to earn cash income. Moreover they were also superior to the existing farm plan in terms of food yield. In the optimal plans cassava gives the highest turnover of 2402 kg/year which is 1748 kg above subsistence needs and hence can be a good source of income if the market is favourable. Moreover its high turnover fits well with its role as a famine crop often used to cushion crop failures in "bad" years. Maize also produces a surplus of 397 kg above minimum consumption needs in the optimal compromise plans. Since even after eliminating some monocropping enterprises all crops will still be produced under mixed and multiple cropping systems, and also food consumption needs will still be met then, the model's suggestion seems plausible. Given the present input-output and price structure, there appears long term possibilities for eliminating some crops as the model suggests.

By comparing the dominant or most important cropping enterprises in the existing and compromise farm plans it can be noted that over the years, farmers have come close to identifying the most profitable cropping enterprises similar to those suggested by the model. Therefore the model have in this sense succeeded to predict or explain the allocative behaviour of the farmers being studied. This asserts the widely accepted idea that farmers have vast experience which need to be tapped by intervention agencies when it comes to introducing new

farming technology. In a way, this also is a test for the validity of the model.

The level of land utilization in the existing farm plan indicate that all available land is cultivated during the year. In order to meet consumption needs, the household uses all land at its disposal and in consequence this limits possibilities for allowing land to lie fallow. This negatively affects soil fertility and hence crop productivity. The compromise farm plans generated by the model were superior to the existing farm plan in terms of fertilizer use and therefore more appealing in terms of maintenance of soil fertility. Nitrogen fertilizer use increased by 84%, 84% and 113%; whereas Phosphorus fertilizer use increased by 8%, 8% and 32% for the L_1 , L_2 and L_{∞} metrics respectively. This may reduce the farmer's need to compensate the decline in crop productivity by expanding farm area whenever the situation allowed. The consequence is to slow the rate of deforestation caused by forest encroachment. These changes in nitrogen and phosphorus use can be explained in terms of variations in ratios of prices of these inputs relative to product prices. If the crops substituted for, are relatively more profitable and with high product prices, the ratio of prices of fertilizers and products will be high. This will lead to the increased purchase and hence use of that particular fertilizer. As long as each unit of fertilizer added to the production process continues to give more returns, farmers will increase the use of that fertilizer to maximize these returns. Farmers probably do not use as much fertilizer because household cash is needed for other items, particularly consumption.

Labour utilization

Labour seasonality is a basic feature in peasant agricultural operations because they are dependent on the seasons of the year. Consequently the work-load is relatively high in some months of the year and low in others to the extent that even compromise farm plans may at times fail to fully even-out labour use variation over different months. The aim of smoothing labour seasonality is to reduce concentration of work stress in only few months of the year (Sankhayan & Øygard 1993). Labour use analysis results indicate labour peak months as presented in table 4.13. In these months labour requirements will exceed labour supply such that there will be no reasonable balance between requirements and availability especially during the peak of the farming season. The peak periods are invariably planting and weeding time and sometimes harvesting. Two responses can be used to resolve labour shortage during peak periods. First is by making use of communal labour. Second is that operations such as weeding may be omitted or not done at the correct juncture. Occasional labour hiring may sometimes be contemplated or desired but is often limited by lack of cash to compensate hired labour. The disparity between supply and demand of labour has direct influence on household income and hence household welfare.

Minimizing labour use variation is crucial in order to identify required changes that can bring even distribution of labour use in the farming system. The aim being to allocate labour more efficiently to improve productivity and people's welfare. The results of minimizing labour use variation are presented in table 4.29. The average monthly levels of labour supply and utilization in the existing and compromise farm plans are presented in table 4.30. As the difference between the level of labour supply and the average labour utilization per month must be ideally null, it can be concluded that compromise farm plans have lower utilization of labour in those months earlier identified as having labour constraint in the existing farm plan. Thus besides achieving

the goal of minimization of labour use variation (labour seasonality) the compromise farm plans are labour saving in the sense that much less labour is required than available labour. This extra labour supply can be used for other economic purposes.

Thus with the compromise farm plans the labour use pattern over different months in a year become more evenly distributed than in the existing production plan. As a result of compromising the objectives, the use of labour declined during the current peak labour use months and increased during the lean or slack months. This being an indication that some labour use redistribution has taken place in the process of evening-out labour use variation. The low levels of labour utilization in the compromise farm plans imply that at the existing farm size, capital supply and technology, labour is not fully employed in the existing production plan. It can be judged from the compromise farm plans that the realistic labour requirement is lower than the current demand such that the apparent labour shortage in constraining months is more due to disguised unemployment than labour shortage. There is a potential for increasing productivity and income levels by making use of this idle or dormant resource.

Table 4.30 Monthly labour supply and utilization in the existing and compromise farm plans (ME-mandays).

Month ¹	Mean labour supply (ME-mandays)	Existing farm plan	Compromise farm plans		
			L ₁	L ₂	L _∞
January	74	113	16	16	16
February	39	117	15	15	15
March	43	137	22	22	22
April	47	106	15	15	15
May	43	84	9	9	9
September	94	103	17	17	17
November	82	83	9	9	9
December	51	108	8	8	8

Source: Model results and own field data

Footnote: 1 only months in which labour is a constraint were included in the model

Marginal analysis indicates that in situations where labour is limiting, the productivity of both land and capital rises as labour supply increases. However, this increase falls at high labour supply levels as diminishing returns set in causing decreasing marginal returns if other things are kept constant (Tibaijuka 1984). In Mhonda village the diminishing marginal returns to labour have already set in, hence resulting into disguised unemployment.

Economic theory on peasant agriculture (Low 1986, Ellis 1987) asserts that a household's labour supply for farmwork depends on the household's subsistence needs which are influenced by the size and composition of the household. In other words, the size of the labour force in the household is dependent on number of household members, age and sex (Tibaijuka 1984). The household seeks to fulfill other needs only after subsistence has been met. This is the stage at which competition between leisure and production for the market becomes important. It is remarkable to note that an average household in Mhonda village can for the most part of the year meet its minimum subsistence needs at present labour misuse. Although cash incomes are low, households continue to survive because subsistence needs are fulfilled and the little cash obtained meets some basic minimum cash requiring obligations.

The farmer's decision to produce for the market implies to increase labour input in farming once subsistence needs have been met. This decision cannot be answered by the model. However, if it is hypothesized that the farmer is expected to maximize cash income, then chances are that there will be more labour input in farming at least where labour shows increasing returns. In reality however, it is not easy to tell whether farmers will find established productivities of land and labour as enough incentives to increase their labour input. The role of price incentives and "incentive" goods in influencing farmer's decision to increase production has been pointed out by Gibbon, Havnevik & Hermele (1993) and Somogyi (1989). Since farmers are not aiming at merely maximizing cash incomes, but also at ensuring survival in case of crop failures, there is a limit to what price incentives can do to influence market production. Therefore the direction of labour input in farming due to such incentives cannot be determined theoretically. Empirical research on the matter can provide an answer.

Division of labour is another factor that affects labour supply and demand in the farm household. The farm plans discussed thus far are based on the situation where there is no distinct division of labour at least in farming activities. This is the situation revealed by the field survey and it is the one modelled in the basic model. There is a less distinct division of labour in farming activities in Mhonda village (table 4.3), hence a "generalized" division of labour. All members of the household are assumed to engage equally in farming as a profitable enterprise regardless of gender. Certainly there are some few roles in which either men or women participate more due to their efficiency in doing them. Also some community traditions still ascribe to some kind of division of labour between sexes hence the notions such as "man's work" and "woman's work". For example, women have greater participation in domestic chores than men. In this study, however, these are considered not to shift the balance of farming as an economic activity. Nonetheless the natural fact that active adults (16-55 years of age) work more than children was taken into account by aggregating household labour into adult or man-equivalents. So was the fact that men have greater ability to physical performance than women and hence have greater potential for productivity particularly in a society where human muscle is the most reliable source of power for most farm operations. The rather equitable participation of both sexes in farming activities found in Mhonda village has the advantage of increasing possibilities to activate both sexes' labour for production of surplus food crops for the market. Sharp divisions of labour would lead to lower labour input by some groups, particularly men due to limited farm activities in which they would participate.

Working capital effect on the other factors of production and deforestation

From survey results in Mhonda village, the highest working capital attainable (i.e. working capital limit) is T.Shs. 163950 per household per year. This includes money from the farmer's own savings and credit from local money lenders and state institutions. Nonetheless, there is no guarantee of getting loans from state institutions. Since money from this source constitutes the biggest proportion (92%) of total working capital supply, failure to access it influences strongly on the farmer. A model run was implemented to find out what will happen if the assumption about availability of institutional loan is taken out. The result showed that a lower net income of T.Shs. 185323 was obtained compared to the net income of T.Shs. 282800 in the basic plan. Moreover area of cultivated farmland was reduced by 0.4 ha/ household per year because 2.1 ha/household per year were cultivated instead of 2.5 ha /household per year. The impact of this on deforestation is to reduce the demand for farm expansion hence lowering deforestation pressure. However, the small cultivated area due to lack of cash is often poorly managed therefore enhancing soil degradation. Since capital is a limiting factor to the level of utilization of the other factors of production (land and labour), then under conditions of non-limiting working capital supply, the difference between the level of utilization of working capital and maximum working capital supply must be null or positive. Thus under the existing technology and farm size in Mhonda village, capital is limiting because the level utilized is below the optimal level. This limitation would increase even further if farming technology improved and if institutional credit will not be forthcoming.

Working Capital is a prerequisite for improvement in farming technology because it has to be invested in form of inputs. When available it raises the average productivity of factors of production through an outward shift of the production function (Mansfield 1988). That means the marginal value products of land, and labour rise with increase in capital. Schultz (1964) and Boserup (1966) asserted that adoption of modern farming methods depends among other things on the efficient provision of inputs which depends on capital. Since peasants in Mhonda village are unable to raise all the working capital they need (their savings constitute only 2% of total working capital supply per year), capital supply will remain a limiting factor to agricultural development in Mhonda village. Given the low cash income levels obtained and the ever increasing demand for consumer goods, it is unlikely that farmers will invest more in agriculture using cash obtained from farming activities since this requires fairly a large proportion of the household's income. This makes the idea of injecting cash from other sources such as loans a more preferable option. Nevertheless, in situations where affordable and reliable loans are not forthcoming and risk in terms of income fluctuation is high, farmers are unlikely to go for loans because these can be perceived as additional risk. From the basic model results in table 4.29 the level of fertilizer use in the compromise farm plans is higher than in the existing average farm plan. This means a need for more working capital. Working capital used increased in all compromise farm plans compared to the existing plan. This can be explained by the fact that more inputs are usually needed for an improved production. The requirement of more working capital expenditure in the compromise farm plans stresses the fact that capital is limiting. The rising use of fertilizer may be an improvement as a goal. This however, can only be achieved with working capital. In the absence of working capital sources farmers will therefore resort to

farm expansion to compensate for low soil fertility by expanding their farms to maintain harvest levels hence causing deforestation through forest clearing to open up new farmland.

In the presence of working capital, farm improvement can be envisaged. Since the improved technologies considered in the model are land saving (intensive) it can be observed that higher working capital levels will not lead to bigger area being cultivated. In view of land shortage due to population growth, a strategy of increasing production through intensification rather than expansion (as observed also by Boserup (1966) is preferable, if not the only alternative in the long run, to rescue forest land. Besides, intensification is the only sure way to reach the majority of farm holdings thus guaranteeing better income distribution and equity. This is a central issue in rural development policy which is partly discussed in Chapter 2 of this report.

Resources and their shadow prices (Marginal Product Values) and impact on deforestation

In the compromise farm plans, one important aspect of economic importance is the types of limiting resources and the associated marginal value products (MVP's) which are also referred to as shadow prices or dual values. Table 4.31 presents a summary of crops, resources and their shadow prices as generated in the basic model. It can be observed that for all model situations in the compromise farm plans, available land is able to meet food requirements hence is sufficient for subsistence. This suggests that it is possible to adopt any of the compromise farm plans suggested by the model and be able to achieve it using only the currently available land. This has a positive implication on reducing deforestation pressure because it means that using the existing farming technology, farmers can optimize their resources without having to expand their farms. This point is also observable from the negative shadow price of land.

The negative shadow price on land is far below the observed price of land (T.shs. 25000 per hectare). This difference is due to the static nature of the basic model. In reality land is a capital asset which enables a farmer to obtain higher capital incomes in subsequent years. Thus it has a higher value which cannot be captured by a static, one period model. However, by incorporating the dynamic factor, population growth, this model's shortcoming is rectified and the shadow price of land rises to reflect the reality as is evident with the high shadow prices of short rain and vegetable land clearing activities. This is also evident in the benefit-cost analysis of expanding farmland through new land clearing. The implication being that new land clearing with a positive shadow price is beneficial to the farmer because he will gain benefit equal in magnitude to the value of shadow price for every unit of land he expands. However, due to the arduous nature of new land clearing, it was observed during the field survey that it is usually done only when it is imperative.

Labour is in reality not limiting under the existing farming technology because in all months included in the model it has a zero shadow price. Capital also has a zero shadow price in all model situations. However, it is still perceived as being a limiting factor despite its low shadow price. The reason is that in the model it is assumed that there is a possibility for the farmer to get a loan from state credit institutions. However, there is no guarantee that this loan will be accessed. Although about 80 percent of interviewed farmers reported that they have benefitted

from credit scheme in the past such loans have not been forthcoming every year as the model assumes. In this situation capital remains a limiting resource. The amount of working capital (T.Shs. 163950) set as a limit in this model was relatively high when institutional loan is included. However, when such loans are obtained at the level expected in the model, then the current farming technology and farm size fails to utilize all the capital because only 37% of total working capital is used for crop production in the existing plan. That may explain why working capital has very low shadow price in table 4.31. Following the production theory, the marginal product of capital declines as relatively more capital is used in producing any level of output (Dornbusch & Fischer 1990).

In table 4.31, fertilizer and manure also have negative shadow prices for the same reason that capital supplied in the model exceeds the level required under existing technology and farm size. This has made it possible for the model to purchase fertilizer inputs which seem adequate as negative shadow prices on these resources imply. Certainly with improvement in farming methods or in the absence of institutional credit, these resources are very limiting. As far as crops are concerned, those most important staple crops have high shadow prices. A peasant farmer would benefit more by growing those crops which have high shadow price because they have higher contribution per unit of output.

Table 4.31 Shadow prices for crops and limiting resources in the existing and compromise farm plans (T.Shs./ha)

Limiting resources and crops	Compromise farm plans		
	L1	L2	L _∞
TOTAL LAND:	-14690	-35460	-14690
NEW LAND CLEARING:			
Long rain land	0	0	0
Short rain land	14691	35456	14691
Vegetable land	5241	12649	5241
WORKING CAPITAL:	0	0	0
LABOUR:			
January	0	0	0
February	0	0	0
March	0	0	0
April	0	0	0
May	0	0	0
September	0	0	0
November	0	0	0
December	0	0	0
CROPS:			
Monocropping:			
MSRU	3783	9130	3783
MLRU	13103	31625	13103
BSRU	1957	4723	1957
BLRU	0	0	0
Cassava	7452	17985	7452
Rice	0	0	0
Sorghum	5759	13900	5759
Vegetable	0	0	0
Mixed cropping:			
SRM/B	5108	12327	5108
LRM/B	0	0	0
Maize/Sorghum	0	0	0
Cassava/Beans	0	0	0
M/B/C/S	0	0	0
Banana/Cassava	0	0	0
Fruit/Cassava	0	0	0
Minor crops	0	0	0
Multiple cropping:			
Maize/Beans	0	0	0
Beans	2932	7077	2932
FERTILIZER:			
Nitrogen	-10	-23	-10
Phosphorus	-13	-31	-13
MANURE:	-5090	-12280	-5090

Source: Model results

Risk aversion by households and impact on land use and forest encroachment

To safeguard against risk conditions especially the vagaries of nature (drought and disease or pest epidemics) and market variations, farmers were found to practice several techniques to avert risk. Diversification of production, growing of disease resistant crops, growing root crops and staggering in planting time were found to be the most prominent ways of minimizing risk in production. As the basic model shows, there are several (18) crop production enterprises in which a variety of crops are raised. Under the existing cropping pattern, cassava, vegetable and rice were most profitable under monoculture cropping. However, mixed cropping of maize, beans, cassava and sorghum gave the highest returns. This mixed production enterprise is more appealing because by having a number of crops it also caters for risk due to its implicit diversification. Moreover it includes the emergency crop, cassava, which is crucial in an environment of uncertainty and frequent crop failures.

Cassava is raised as an emergence crop in case of crop failures. In fact, cultivation of cassava as an emergence crop is coerced by the local administration in Mhonda village and areas around it. One shortcoming of this policy as reported during the study is that sometimes, the emergence crop cassava, is in bumper harvest and is sometimes neglected or left unharvested when there is no market for it. Also at times, the absence of an immediate anticipated or perceived risk such as hunger, may lead to neglect of such a crop because it is considered to belong to an inferior class of food crops. This is not likely to be a problem in the future as food shortages are increasing in the wake of the growing population and expanding market for food crops. Actually the role of food crops as an income earner for the family has increased due to the growing market. Improved marketing conditions could increase returns from these crops even further. The food crops market for the household has depended on total farm output in relation to household subsistence needs, producer prices offered, availability of markets and other sources of household income. Since food crops feature to be a reliable source of income for the household, in the long-term therefore, there is need to establish more efficient arrangements for guaranteeing food security to the rural households. For example increased specialization in food production could be one approach which, beside increasing efficiency it could also release labour currently tied up in producing emergency food crops mainly cassava which, in good years has little utilization and sale value.

It should be emphasized however that in the absence of schemes guaranteeing food supplies to rural households, in time of poor harvests, then diversification remains the only viable and rational option and thus must continue. The diversification strategy was reported to be a means of ensuring survival in case of crop failures, and blends well with the traditional farmer's multiple objectives currently not focused at maximizing cash income in any production season. Risk aversion is also closely linked to farm expansion which causes forest encroachment. For example if a farmer chooses a farm plan which gives more weight to income than risk minimization (table 4.38), annual total net income of T.Shs. 163800 per hectare is realized at an annual risk level of T.Shs. 113745 per hectare. However if he chooses a farm plan which gives more weight to risk minimization than total net income he realizes T.Shs. 150060 per hectare at a lower risk level of T.Shs. 112934 per hectare. Hence a farmer has to trade-off in terms of

whether to choose low net income with low risk level or high net income with a corresponding high risk level. The former option in which farming is perceived as a risky venture will reduce pressure on farmland and hence forest encroachment. This is so because the tendency will be to minimize area under crops to avoid risk and consequently the household will strive to meet subsistence requirements as the overriding goal rather than attempting to maximize total net income. The latter option will increase pressure on farmlands causing more land clearing and hence accelerating deforestation. The issue of risk is further discussed in section 4.2.2.8.

Potential for cash crop production in Mhonda village

Survey results in Mhonda village showed that coffee, cardamon, cocoa, cotton and sugar can have the potential to thrive well in areas around Mhonda village. Yet these crops, despite their high value, are not produced in quantities meriting inclusion in the model (less than 5 kg/ha produced) and therefore they were treated as minor crops. In actual fact they have been neglected due to poor marketing services, low producer prices and unavailability of inputs required to produce them. Due to these impediments they have not been able to compete with food crops for productive resources. Moreover the food crops had always enjoyed a ready market and rising producer prices on the parallel market. Thus the production of non-food crops has been rendered unattractive such that these crops' traditional position as money earners has been dislocated and replaced by food crops.

From economic theory cash crops particularly perennial crops like coffee have inelastic supply in the short- and medium-term and therefore ascribe more to efficiency of marketing services than to producer prices in guaranteeing supply. Producer prices despite their limitations in influencing marketed production, are still important in view of competition of crops for meagre productive resources. Since food crops have elastic supply in the short-term due to flexibility in production and short rotation they take advantage and respond quickly to price changes than cash crops, most of which are perennial. It can be asserted that reviving the production of cash crops would be an important step that could strongly augment farmer's income and improve the standard of living. But this requires institutional involvement by the government to remove bottlenecks that impede production of such crops in the area.

4.2.2 Results of sensitivity analysis

One advantage of mathematical programming is the relative ease with which the basic model can be manipulated to investigate the effects of changes in the data related to land, capital, labour and entrepreneurship. In this study, through sensitivity analysis, effects of changes on some parameters and variables such as price, new land clearing and increased consumption due to population growth among others were investigated for the purpose of generating information with policy implications. The results are presented in the section which follows.

4.2.2.1 Impact of population growth on deforestation

This section aims at showing the pressure on forest lands as a result of the burgeoning

population. Land supply and food consumption are used as parameters to test the sensitivity of the model. In this analysis, the study village, Mhonda, lies in close proximity to the tropical forest protected by the government for catchment purposes. The forest is a major source of water, and many forest products and intangible benefits that sustain the lives of communities in the area, particularly for agriculture by way of climate regulation and rivers/streams originating in the catchment forest. However, due to depletion of forest resources in public lands and a belief that best agricultural land lies within natural forest environs, pressure and dependency has mounted on the forest reserve to the extent that it is threatened. Expansion of farmland has at times occurred by way of clearing the protected natural forest reserve through encroachment. This causes deforestation which in this context is defined according to Grainger (1993) as "the temporary or permanent clearance of forest for agriculture or other purposes". For many years the agricultural/forest relations in the area were sustainable (Bjørndalen 1992). However, the trend changed in recent decades as a consequence of fast population growth and demands of the market economy. The most likely scenario is that population will continue to grow in the years to come and this will put more pressure on the already dwindling resources such as farmland and natural forest. Such pressure is caused by the derived demand for food in the short run and both food and human settlement in the long run.

Thus, the basic model was extended by incorporating new land clearing and increased food consumption as functions of population growth. The underlying assumption is that households have a possibility to expand size of farm holdings, and by introducing the new land clearing activity it is possible to capture the dynamic characteristics of the farming system in an otherwise static planning framework. New land clearing demands labour and capital in the first year but the benefits would be available in subsequent years when crops start yielding. Thus by introducing farm expansion activity in the model short-term costs and long-term benefits of expanding the farm are discernible. Similarly the impact of agriculture on deforestation pressure can be analyzed. The results of the sensitivity analysis to test the impact of annual population growth rates of 2.6 % and 3.5 % are presented in tables 4.32 and 4.33 respectively.

In this study land clearing is conceived to be a consequence of growing population which necessitates the need for more land for food production. New land clearing and increased food consumption are taken as functions of population growth over the period of 35 years. In this period farming technology is assumed to remain the same or the annual technology development is included in the assumed growth of 2.6% per annum and 3.5 % per annum so that these figures are net growth after adjustment of technological progress. In both cases the optimum basic farm plan maximizing total net income is presented for comparison. A remarkable difference can be gleaned between the optimum basic farm plan and alternative farm plans as a result of the burgeoning population. The model results show that there is land clearing in order to meet increased food demand. At 2.6 % annual population growth rate, the total cleared land is 0.4 ha/household in year 5 or 0.1 ha/household per year; and is 0.7 ha/household in year 10 or 0.1 ha/household per year. At 3.5 % annual population growth rate, the total cleared land is 0.5 ha/household in year 5 or 0.1 ha/household per year and 1.0 ha/household in year 10 or 0.1 ha/household per year. The size of Mhonda village is 546 households, and the tropical rainforest area in Nguru South Forest Reserve which lies adjacent to Mhonda village is 18800 ha. At

population growth rate of 2.6 % per annum, the total land to be cleared in Mhonda village is 41.0 ha per year or 410 ha in 10 years. This is a deforestation rate of 0.2 % per year. At population growth rate of 3.5 % per annum the total land area to be cleared in Mhonda village is 54.6 ha per year or 546 ha in 10 years. This is a deforestation rate of 0.3 % per annum. The countrywide average for deforestation rate in Tanzania, at population growth rate of 2.8 % per annum, is 0.3 % per year (Sharma 1992). This includes all forest types, however. An aerial photo and GIS-based study in Turiani area, Tanzania by Norris (1990) estimated a tropical rainforest deforestation rate of 0.5% per annum. There are no average country figures for rainforest deforestation in Tanzania for comparison. Based on deforestation rate changes as a result of population growth and under the assumptions of the model, the elasticity of deforestation rate was 1.9 which implies that, if population growth is changed by one percent, deforestation rate would change by 1.9 percent within the same period.

Thus at existing technology, the growing population will result in deforestation unless intensification of agriculture through technological improvements takes place. This deforestation is mainly in form of traditional shifting cultivation and encroachment both based on the slash-and-burn technique of land clearing as presented in Monela (1995). Encroachment cultivation is a response to poverty in order to survive and government inaction over land reform, inequitable systems of land tenure and poor service to agriculture leading to declining crop yields. Deforestation is one important consequence of population growth in the Nguru mountains. Under the assumptions of the model, and at the population growth rates of 2.6 % and 3.5 % (the countrywide average is 2.8% according to 1988 census) and existing technology in Mhonda village, the farming systems practiced by an average household can sustain these population growth rates for a duration of 10 to 15 years. The cut-off year lies between 10 and 15 years. At population growth rates higher than 3.5 the sustainability situation is even more restricted possibly due to lack of land for expansion, decline in productivity and other constraints such as poor farming technology and lack of capital to buy tools for land clearing and other inputs. In the long run the farming systems in Mhonda village are unsustainable to support even one human generation. This calls for the need to devise a strategy that can improve farming technology and thus lead to higher yield levels. Other non-farm economic activities need to be increased in order to improve the economic welfare of the farmer.

According to Palo & Salmi (1987), Palo & Mery (1990) and Palo (1993), there exist a close relationship between agricultural production, deforestation and environmental degradation. Population pressure plays a decisive indirect role as one of the driving force in deforestation process. Growing human population creates increasing domestic demands for food, energy, shelter and services of health and culture which again increase pressure on the various direct agents of deforestation either directly or via more asymmetric and uncertain tenure (Palo & Mery 1990). As the model results indicate population growth in the Mhonda village will increase pressure on the land and other resources. Farmers will turn to new land clearing for additional land and this involves the conversion or replacement of forest by another landuse and thus causes deforestation.

Table 4.32 Optimum farm plans for an average household at a population growth rate of 2.6 % for 35 years¹.

Item	Basic optimum farm plan	Optimum farm plans during the year		
		5	10	> 15
Max income(T.Shs./year)	282800	321060	317520	INFEASIBLE
Min SDI (T.Shs.)	195590	243352	265714	
Min SDL (ME-mandays)	4.43	4.82	5.09	
Land allocation (ha) ² :				
Monocropping				
MSRU	0	0	0	
MLRU	0	0	0	
BSRU	0	0	0	
BLRU	0.025	0.155	0.308	
Cassava	0	0	0	
Rice	0.087	0.099	0.113	
Sorghum	0	0	0	
Vegetable	0.500	0.500	0.500	
Mixed cropping				
SRM/B	0	0	0	
LRM/B	0.261	0	0	
Maize/Sorghum	0.031	0.092	0.228	
Cassava/Beans	0.809	1.153	1.164	
M/B/C/S	0.083	0.018	0	
Banana/Cassava	0.090	0.102	0.117	
Fruit/Cassava	0.131	0.151	0.171	
Minor crops	0.100	0.120	0.140	
Multiple cropping				
Maize/Beans	0.382	0.508	0.274	
Beans	0	0	0.184	
Total cultivated land	2.5	2.9	3.2	
Total cleared land (ha):	0	0.4	0.7	
Fertilizer nutr.(kg):				
Nitrogen	101	99	97	
Phosphorus	41	43	49	
Working capit. (T.Shs.)	77887	87207	96598	
Food consumption (kg):				
Maize	794	658	514	
Beans	506	576	654	
Cassava	2402	3131	3184	
Rice	131	149	170	
Sorghum	69	79	171	
Vegetable	600	600	600	
Banana	108	123	140	
Fruit	46	53	60	
Minor crops	5	6	7	

Source: Model results

Footnote: (1) Assuming same farming technology will prevail over the entire period hence inputs remain the same.

(2) Land allocation is given in three decimal places because truncating to one decimal place would over-estimate the size of land area under each crop

The World Commission on Environment and Development (WCED 1987) sums up the situation thus: "poverty pollutes the environment in its own way.... those who are poor and hungry will often destroy their immediate environment in order to survive: they will cut down forests; their livestock will overgraze grasslands.... the cumulative effect..... is so far reaching as to make poverty itself a major global scourge". Thus it is poverty that is responsible for the destruction of the environment, not the poor. Subsistence farmers in developing countries account for more than 60 percent of the loss of tropical forests annually. At the same time as forests and scattered trees in various ways support agriculture, forests and woodlands are looked upon as important reserves for agricultural expansion. A major cause of deforestation, consequently is land clearing for agriculture (Grainger 1993). Even in the causal analysis of deforestation (Palo & Mery 1990), which is based on an interdisciplinary systems model and system causality, land clearing for agricultural expansion features prominently as one cause of topical deforestation. Apart from the extension of cultivated area, destructive agricultural practices of various kinds are also important causes of deforestation and land degradation (Sharma 1992). Formerly, clearing for agriculture alone did not usually lead to land degradation as traditional farming systems generally were in harmony with conservation of land. However under the influence of growing population, agricultural modernizers and economic demands which have pushed poor peasants to cultivation of marginal lands, the traditional farming system to a large extent has been given up and thus leading to unsustainable land use practices which cause deforestation (Ahlback 1992). The poor peasants, according to Harrison (1987) are "pressing up against the limits of cultivation and sometimes beyond". Loss of soil fertility resulting in poorer crop yields, then, leads to a need to move often to better land though increasingly difficult to find. A result is lower yield compensated with even larger areas than otherwise needed and stepped up deforestation through forest clearing.

Although population pressure can lead to deforestation as the model results indicate, neo-classical school of economics has considered population pressure either as neutral or beneficial to development (Boserup 1965, 1990). According to this school of thought more people means more demand, more labour force, more talented brains and better technology, economies of scale and lower production and distribution costs. Hansen (1993) supports this viewpoint by noting that "growing human populations are not necessarily negative: more people mean more human contacts, more new ideas and constitute inspiration for development. Simultaneous neglect of public investments in education, health, and job creation, however, nullifies the impact of increased human potential, and gives rise to a population problem". According to this viewpoint therefore, deforestation and other environmental deterioration are assumed to be taken care of by the competitive markets. If natural forests for instance would become economically scarce, their increasing real price would induce more investments in forestry, hence the sustainability is maintained automatically (Woods 1987, Boserup 1990). Nonetheless, Palo & Mery (1990) dispute this by observing that " In most developing countries, most publicly owned forests are an open access resource. Open access resources in the form of forests create more market failures. Under open access conditions increasing scarcity of forest does not raise its price sufficiently (if at all) in order to mobilize adequate management or substitution".

Table 4.33 Optimum farm plans for an average household at a population growth rate of 3.5 % for 35 years¹.

Item	Basic optimum farm plan	Optimum farm plans during the year		
		5	10	> 15
Max income(T.Shs./year)	282800	330060	322530	INFEASIBLE
Min SDI (T.Shs.)	195590	255054	295199	
Min SDL (ME-madays)	4.43	5.00	6.19	
Land allocation (ha) ² :				
Monocropping				
MSRU	0	0	0	
MLRU	0	0	0	
BSRU	0	0	0	
BLRU	0.025	0.196	0.553	
Cassava	0	0	0	
Rice	0.087	0.104	0.123	
Sorghum	0	0	0	
Vegetable	0.500	0.500	0.500	
Mixed cropping				
SRM/B	0	0	0	
LRM/B	0.261	0	0	
Maize/Sorghum	0.031	0.108	0.500	
Cassava/Beans	0.809	1.217	1.094	
M/B/C/S	0.083	0.002	0	
Banana/Cassava	0.090	0.107	0.127	
Fruit/Cassava	0.131	0.157	0.186	
Minor crops	0.100	0.120	0.140	
Multiple cropping				
Maize/Beans	0.382	0.488	0.087	
Beans	0	0	0.190	
Total cultivated land	2.5	3	3.5	
Total cleared land (ha):	0	0.5	1.0	
Fertilizer nutr.(kg):				
Nitrogen	101	99	99	
Phosphorus	41	43	56	
Working capit. (T.Shs.)	77887	89788	105280	
Food consumption (kg):				
Maize	791	639	560	
Beans	506	601	714	
Cassava	2402	3270	3068	
Rice	131	156	185	
Sorghum	69	82	375	
Vegetable	600	600	600	
Banana	108	129	153	
Fruit	46	55	65	
Minor crops	5	6	7	

Source: Model results

Footnote: (1) Assuming same farming technology will prevail over the entire period hence inputs remain the same.

(2) Land allocation is given in three decimal places because truncating to one decimal place would over-estimate the size of land area under each crop

Boserup (1965) advanced the theory that denser populations induce better technologies. Such technologies are an important strategy for improving farming technology as well. The possible connection between deforestation in the Nguru mountains and Boserup's theory of population pressure and technological change is that in this area, population density has not reached a critical level because alternative land can still be found in the area. Forest encroachment is one possibility to get new land. This causes deforestation. Another way is to move to another area or region where land is still available and population density is lower than in the Nguru mountains. Such possibility still exist in Tanzania. Moreover, people in the Nguru mountains still find other survival means from what we can refer to as "resources for last resort" such as nontimber forest products collected from the rain forest and woodlands. The availability of such alternatives may be one reason that population pressure has not induced better farming technology in this area.

Poverty is one of the main underlying factors contributing to deforestation and under conditions of poverty like those which exist in Mhonda village neo-classical assumptions stated above, may not operate as expected thus failing to control deforestation. Under conditions of absolute poverty, the situation is that the majority of rural poor rely heavily on forests and woodlands for income and subsistence hence exert much pressure on these resources. Planned control by government and automatic control by the market ("invisible hand") are two primary mechanisms that ought to control socio-economic development toward social well-being within economies. However, in Tanzania both of them have failed to control deforestation. The government is unable to control deforestation through policy measures or coercion, and the market mechanisms provide no negative feedback loops to check deforestation because of wide spread market failures, ill-defined property and tenure rights and the fact that markets play a minor role in the distribution of nontimber forest products which to a great extent contribute to deforestation pressure. Although in the past traditional rural communities had developed comparatively sustainable forms of resource use, circumstances beyond their control have compelled many to change their traditional ways of resource use. Consequently they have resorted to exploiting forests unsustainably for short-term gains. It is under such circumstances that the forests in the Nguru mountains find themselves. Alleviating poverty among local communities seem to be a necessary starting point to save these forests from total destruction.

4.2.2.2 Cost-benefit analysis of farm expansion by clearing new land (deforestation) as a result of population growth

Peasant agriculture involves long-term investment decisions in the sense that a farmer with a possibility to expand a farm holding needs to know whether or not it is worthwhile to engage in that kind of enterprise. The farmer may wish also to know the magnitude of the costs and eventual benefits of farm expansion by land clearing. Such kind of information is essential because land clearing is an arduous task which at times involves violating the laws governing the forest reserve by way of encroachment. It may also involve invading the neighbour's land. By introducing a farm expansion requirement in the model, a cost-benefit analysis of this activity was conducted and the results are presented in table 4.34.

Table 4.34 Cost-Benefit analysis of farm expansion by clearing new land in Mhonda village over a 35 year period (T.Shs.).

year	Size of farm land (ha)	Gross margin			Cost of having cleared land (a-b)	NPV of cost at 6%	Yearly benefits due to clearing (c-a)	NPV of benefits at 6%	NPV of net benefits at 6%
		With-out clearing (a)	With clearing (b)	In following year ¹ No clearing (c)					
5	0.4	352612	342612	367602	10000	7473	14990	11204	3731
15	0.9	464438	441938	482758	22500	9389	18320	7644	-1745
25	1.1	610132	582632	633449	27500	6408	23317	5433	-975
35	1.4	706420	671420	735324	35000	4554	28904	3761	-793

Source: Computed from results of the model assuming population growth rate of 2.6 percent per annum

Footnote: 1 High gross margin is due to cassava crop harvested one year after land clearing was done.

Assuming that cassava crop which has an establishment period of one year is planted, then a farmer who planted such crop in a previous year would obtain the benefit in the following year equal to the amount shown in column 8 of table 4.34. It can be observed that NPV (at 6% discount rate) of yearly benefits of having cleared land is highest when the initial farm size (i.e. of cleared land) is small and declines progressively to reach zero at the farm size where land becomes surplus with a shadow price (MVP) of zero. The NPV of net benefits is positive when farm size is small and becomes negative at later years when farm size become large and land is surplus. There is no net gain in these and subsequent years as costs are not recovered. For a farmer who started without land, the NPV of yearly benefits will be even higher above T.Shs. 7331. The year of breaking-even (i.e. the time when the total discounted accumulated yearly benefits equal the discounted cost of having cleared land) lies between year 5 and year 15. It can be inferred from the data in table 4.34 and by applying economic theory that the cost of clearing land is the difference between the TR curve without and with land clearing activity. The benefit is the income obtained in the second year and subsequent years. Its magnitude will depend on whether or not the farmer wishes to continue with expansion by new land clearing. Of course this depends on many factors such as capital availability, labour supply and availability of land to be cleared.

This analysis shows that expansion of farmland by new land clearing is most profitable on small farms which can break-even faster because they have lower operating costs. Moreover large farms are the ones which suffer from labour shortage than small ones. This follows directly from the

results of the earlier analysis on the shadow price of farm-holdings. Thus households with small farms are the ones more concerned with clearing new land to expand their farms holdings. This sounds logical as these are essentially marginalized households. However, their efforts are at times curtailed by lack of land for expansion. Efforts against woodland degradation and deforestation also discourage farm expansion through land clearing.

4.2.2.3 Impact of population growth on total net income.

A comparison of net cash incomes and resource productivity on farms of different sizes under growing food consumption due to population growth is provided in tables 4.32 and 4.33. These results show a declining trend in net cash income and hence per capita income over time. This may ascribe to an increase in food demand due to population growth and hence lesser crop output is left for sale to earn cash income. A rational farmer, in accordance with the model's prediction, would ensure subsistence needs before he commits any output for sale. In real life situation farmers do not consider cash income as the superseding or overriding goal. In most cases priority is given to food production and cultural needs before the goal of cash income is pursued.

Nevertheless, net cash income has a direct bearing on purchasing power of a household, hence it affects its consumption of market goods and so has a bearing on the level of savings, investment ability and standard of living. Thus with declining income due to population growth the people's ability to service agriculture will go down forcing them to resort to poor land use practices, thus enhancing deforestation pressure. The model results also indicate that with growing population the level of working capital needed will also increase hence further enhancing deterioration of the household's ability to service agriculture. With declining income from farm output, the need for access to a credit facility is indispensable in order to raise the level of capital which determines the amount of agricultural inputs that are used. The responsive behaviour of the farmer under changing conditions of capital supply and the impact of capital supply on deforestation pressure are analyzed in later sections.

4.2.2.4 Impact of price changes on deforestation pressure

Crop price is an important variable when evaluating farmer's efforts (Gittinger 1992). The simplest and realistic way to test how sensitive optimal plans are for market changes at the farm level is to perform a sensitivity analysis on prices. By changing price levels the effects of market limitations can be studied.

In Tanzania, producer prices paid to farmers are very low (Somogyi 1989; Gibbon, Havnevik & Hermele 1993). For example, the Morogoro Region Cooperative Union (MRCU) which was formed to service smallholder farmers ironically leads in giving them lowest producer prices among the crop markets in table 4.17. Producer prices if properly fixed are known to be an incentive to farmers to the extent that changes in these prices have often been one of the important structural adjustment recommendations to foster institutional reforms in agriculture (FAO 1991). Therefore an increase in producer prices has been used as a way to stimulate increased crop production because higher producer prices give farmers ability to purchase inputs

and improve agriculture (Gibbon, Havnevik & Hermele 1993). High yield varieties of crops such as hybrid maize and chemical fertilizers which resulted into new cropping practices were introduced along similar lines (Kaoneka 1993). Based on these facts, a sensitivity analysis was conducted to elucidate the effect of changes in crop producer prices on optimum farm plans generated by the model. The purpose was to find out how farmers would respond to changes in producer prices. Also to look into the price elasticity of supply of tradeable crops particularly maize which is a common staple throughout Tanzania.

The sensitivity analysis on the effect of changes of producer prices on optimum farm plans hinges on the partial equilibrium principle whose main contention is that a change in producer price of one crop can take place without causing a significant change in the prices of other crops (Mansfield 1991). The concept of equilibrium refers to the situation where there is no tendency for change such that an equilibrium price is one that can be maintained despite the forces at work to stimulate a change in price (Dornbusch & Fischer 1990). In this analysis, it is conceived that a crop of high commercial value like maize will be affected by changes in producer prices than less tradeable crops. Experience in Tanzania shows that government pricing policy has focused mainly on maize and in consequence, the major maize producing areas in Tanzania were among big recipients of government subsidy in form of farm inputs particularly fertilizer and chemicals (Somogyi 1989). Such price controls and subsidies had great impact on agricultural development in the country (Gibbon, Havnevik & Hermele 1993).

The results of the sensitivity analysis to investigate the impact of price changes on the optimum farm plan are presented in table 4.35 and for the purpose of comparison both the basic optimum and alternative farm plans are given. Remarkable differences can be discerned between the basic optimum and compromise farm plans. Since the main source of income to the household is sale of agricultural produce, the rising of farm incomes as a consequence of rising producer prices would lead to increased savings and therefore increase in investment in farming as it would be profitable to do so due to profit foregone for not engaging in more farming. Moreover, increased producer prices would provide better returns to labour, an incentive that would attract most household members to actively participate in farming activities. Increased financial returns from farming, under limited land for expansion, may be used to alleviate other constraints to farming which may also promote intensification rather than expansion of farmlands to reduce deforestation pressure. Currently an average household spends about 2% of its total income on farm investments. It is reasonable to assume that this investment rate would be maintained or even increased as farm incomes improve.

Table 4.35 Results of sensitivity analysis to test the impact of price changes on model results

Item/resource use	Basic optimum farm plan	Optimum farm plans at percentage price change of			
		10 %	20 %	50 %	100 %
Max income(T.Shs./year)	282800	334620	383950	528310	773860
Min SDI (T.Shs.)	195590	200964	200964	195590	199109
Min SDL (ME-mandays)	4.43	4.28	4.28	4.43	4.32
Land allocation (ha) ² :					
Monocropping					
MSRU	0	0	0	0	0
MLRU	0	0	0	0	0
BSRU	0	0	0	0	0.052
BLRU	0.025	0.083	0.083	0.025	0.001
Cassava	0	0	0	0	0
Rice	0.087	0.087	0.087	0.087	0.087
Sorghum	0	0	0	0	0
Vegetable	0.500	0.500	0.500	0.500	0.500
Mixed cropping					
SRM/B	0	0	0	0	0
LRM/B	0.261	0.094	0.094	0.261	0.230
Maize/Sorghum	0.031	0	0	0.031	0.052
Cassava/Beans	0.809	0.877	0.877	0.809	0.841
M/B/C/S	0.083	0.125	0.125	0.083	0.054
Banana/Cassava	0.090	0.090	0.090	0.090	0.090
Fruit/Cassava	0.131	0.131	0.131	0.131	0.131
Minor crops	0.100	0.100	0.100	0.100	0.100
Multiple cropping					
Maize/Beans	0.382	0.413	0.413	0.382	0.413
Beans	0	0	0	0	0
Total cultivated land	2.5	2.5	2.5	2.5	2.5
Fertilizer nutr.(kg):					
Nitrogen	101	98	98	101	101
Phosphorus	41	41	41	41	42
Working capit. (T.Shs.)	77887	77991	77991	77887	79329
Food consumption (kg):					
Maize	794	645	654	794	794
Beans	506	506	506	506	506
Cassava	2402	2633	2633	2402	2422
Rice	131	131	131	131	131
Sorghum	69	69	69	69	69
Vegetable	600	600	600	600	600
Banana	108	108	108	108	108
Fruit	46	46	46	46	46
Minor crops	5	5	5	5	5

Source: Model results

Footnote: (1) Assuming same farming technology will prevail over the entire period hence inputs remain the same.

(2) Land allocation is given in three decimal places because truncating to one decimal place would over-estimate the size of land area under each crop

Therefore offering remunerative producer prices is one possible way to mitigate or surmount the problem of capital shortage and also is a way to improve standard of living and prevent deforestation from agricultural expansion. Although price has been widely mentioned to be an incentive to increased production (Gibbon, Havnevik & Hermele 1993), yet it should be recalled that farmers not only aim at maximizing cash income, but they also aim at ensuring survival in case of crop failures. Lipton (1968) refers to this as a "survival strategy". There is therefore a limit to what price incentives can do to influence marketed production. In the long term more efficient ways of guaranteeing future food supplies would possibly release labour to engage in marketable production. Higher increases in crop producer prices may change the way resources are allocated. From table 4.35, as crop price is increased (e.g. by 10 %) the area allocated to various crop enterprises changed in comparison with the basic plan with more area allocated to more profitable crops. The number of crop enterprises also changed. Working capital use increased at higher prices implying that higher income induce more input use and hence may lead to higher crop yields. In all model situations household food needs were met.

4.2.2.5 Price elasticity of crops and deforestation

In the presence of short-term capital the supply of annual crops unlike perennial crops is price elastic in both the short-and intermediate-terms such that not long time is needed for producers (farmers) to adjust to price changes (Tibaijuka 1984). Because of a relatively short establishment period of less than a year and for the sake of immediate cash incomes, responses to higher prices can theoretically be easily made provided farmers have the necessary investment capital for establishment. In practice this capital is lacking hence no quick adjustments can be expected on the average farm household unless capital in form of credit is supplied. The low levels of liquid cash and poor farm implements on an average household can confirm this argument.

In the absence of a credit facility for the farmers then the changes will be long term and under such circumstances, the farmers will rely on their savings for investment. The positive direction of the income movement as a result of producer price incentives can promote these changes provided other factors remain constant.

In the sensitivity analysis on price changes it is assumed that the model developed here can predict the effect of changing crop price in the short and medium term. This can be inferred from an increase in total net income at all price increases shown in table 4.35. In the Tanzanian condition maize supply is more sensitive to price changes than less tradeable crops due to its high commercial value. However, as earlier mentioned the supply of maize will remain inelastic at least in the short run in the absence of capital. Kaoneka (1993) using data from Lukozi village in the Usambara mountains found that the price elasticity of supply of maize was 0.24, confirming that the supply curve for maize is inelastic in the absence of short-term capital supply. Under this situation even if the price of maize is increased, the percentage increase in quantity of maize produced will be less than the percentage increase in price of maize.

This inelastic nature of maize price in the absence of capital conforms with the fact that peasant farmers lack cash and hence have limited ability to expand or intensify farm production based on their own savings. Incidentally, the elasticity of deforestation rate due to increase in producer

price is low. Under assumptions of the model, elasticity of deforestation rate was 0.7, implying that if all crop prices are changed by one percent, deforestation rate would change by 0.7 percent within the same period. In the absence of capital the only option is for the peasant farmers to make marginal increases by manipulating cropping patterns and improve tending of crops.

4.2.2.6 Effect of changes of total working capital supply on resources use and deforestation

Economic resources are of a variety of types and economists have customarily classified economic resources into land, labour, capital and entrepreneurship (Mansfield 1991). Each of these categories contains such an enormous variety of resources with large amount of variation (Hartwick & Olewiler 1986). In this classification capital includes equipment, buildings, inventories, raw materials and other non-human producible resources that contribute to the production, marketing and distribution of goods and services (*ibid*). In this study, capital implies working capital (i.e. money for purchase of tools, fertilizer and chemicals) and equity value of farm and home buildings and raw materials such as stock of seed from previous harvest. However, only total working capital will be considered in this scenario. According to Low (1986) capital in peasant agriculture, is one of the most important limiting factors to improvement in productivity. The lack of cash impairs farmer's ability to purchase inputs for servicing agriculture consequently causes peasants to apply poor land use practices.

The analysis described in this section aims at investigating the effect of changes in total working capital on the optimal farm plans and deforestation. To conduct this analysis, three alternative scenarios were investigated. In scenario 1, there is no land clearing and working capital is unrestricted. In scenario 2, land clearing is allowed under restricted working capital condition. In scenario 3, land clearing is allowed under unrestricted working capital condition. The results obtained are presented in table 4.36. The total net income generated per year is T.Shs. 282800, 492430 and 588500 for the first, second and third scenarios respectively. The effect of changing total capital supply on model results is evident in scenarios 2 and 3 in which total net income increases substantially if compared to a total net income of T.Shs. 282800 in the basic farm plan. However, this large income is realized at a high level of risk and high labour use variation compared to the basic plan. Capital therefore, has the effect of shifting the whole level of income upwards. The rising income follows the theoretical expectations that net cash income would increase progressively until it reaches a maximum and would level off when the shadow price (MVP) of land drops to zero and land becomes surplus (Tibaijuka 1984).

Based on these results it can be concluded that one effect of providing additional working capital is to increase the use of market inputs mainly the fertilizes nitrogen and phosphorus. In Scenario 3, the use of nitrogen fertilizer increased by 27% while phosphorus increased by 57% over the basic farm plan. Another result is expansion of farmland through forest land clearing hence causing deforestation. From results of the model, the land cleared as a result of increased capital supply (when land clearing was allowed) was 1.325 ha/household per year in scenario 2 and 2.50 ha/household per year in scenario 3, which is an increase of 53% and 100% per year over the present farm size of 2.5 ha/household per year respectively. This equals a deforestation rate of 3.9% of the forest area per year and 7.3 % of the forest area per year for scenarios 2 and 3

respectively, based on total area of 18800 ha for the Nguru South Forest Reserve and 546 households in Mhonda village. The additional land resulting from land clearing in scenarios 2 and 3 permits an increase of crop enterprises as shown in table 4.36. Therefore, land allocation is altered considerably following the increase in total working capital supply. An increase in food consumption can also be gleaned.

More impact of change in working capital is felt in scenario 3 when an increase in working capital is associated with provision for land clearing. This implies that under the prevailing resource endowment in Mhonda village, access to credit would stimulate expansion of farmland through land clearing until when land to be cleared and labour become limiting. However, forest land clearing causes deforestation and this is undesirable because it degrades the environment by reducing forest/vegetation cover. The farmer could be more rational by using additional working capital obtained for instance from a credit facility to improve agriculture by intensification rather than by expansion of farmland through forest clearing. Intensification of agriculture has been advanced as a viable option to increase crop production and raise standard of living in peasant agriculture especially under conditions of population pressure which according to Boserup (1965) induces technological improvement. This analysis portrays working capital as a very important input which determines to some extent the size of farmland a farmer would be willing to put under crop. It also to some extent determines the level of the farmers efficiency in crop production. Since suitable surplus arable land is not available, expansion of farmland will most likely be effected through new land clearing. This partly explains encroachment taking place in the protected forest adjacent to Mhonda village.

At times, even if additional capital was provided, labour may be limiting factor especially during peak periods. Forest land clearing being an arduous task demands substantial labour input from men who naturally happen to have higher prowess than women. The fact that same men have to perform other compelling duties may at times limit their availability for new land clearing activity at peak periods. This may limit the amount of land cleared in one season. By allowing land clearing in scenarios 2 and 3 land allocation changed to cater for new land added from land clearing activities. This added farmland requires more labour and other inputs to make it productive. Based on deforestation rate changes as a result of increasing working capital and under the assumptions of the model, the elasticity of deforestation rate was 1.3 which implies that, if working capital is changed by one percent, deforestation rate would change by 1.3 percent within the same period.

Table 4.36 Optimum farm plans when total working capital and land area are varied for an average household in Mhonda village

Level of variable/objective function value,	Optimum farm plans in various scenarios		
	Scenario 1	Scenario 2	Scenario 3
Max income(T.Shs./year)	282800	492430	588500
Min SDI (T.Shs.)	195590	329912	482145
Min SDL (ME-mandays)	3.45	7.08	9.74
Land allocation (ha) ² :			
Monocropping			
MSRU	0	0	0
MLRU	0	0	0
BSRU	0	0	0
BLRU	0.025	0.013	0
Cassava	0	1.198	0
Rice	0.087	0.087	0.087
Sorghum	0	0	0
Vegetable	0.500	0.500	0.500
Mixed cropping			
SRM/B	0	0	0
LRM/B	0.261	0	0
Maize/Sorghum	0.031	0.092	1.457
Cassava/Beans	0.809	0.967	1.979
M/B/C/S	0.083	0	0.200
Banana/Cassava	0.090	0.090	0.090
Fruit/Cassava	0.131	0.131	0.131
Minor crops	0.100	0.100	0.100
Multiple cropping			
Maize/Beans	0.382	0.647	0.456
Beans	0	0	0
Total cultivated land (ha)	2.5	2.5	2.5
Total cleared land (ha)	0	1.325	2.5
Fertilizer nutr.(kg):			
Nitrogen	101	100	128
Phosphorus	41	41	64
Working capit. (T.Shs.)	77887	81441	128820
Food consumption (kg):			
Maize	794	797	1996
Beans	506	506	672
Cassava	2402	654	5301
Rice	131	131	131
Sorghum	69	69	1203
Vegetable	600	600	600
Banana	108	108	108
Fruit	46	46	46
Minor crops	5	5	5

Source: Model results

Footnote: (1) Symbols remain as defined earlier

(2) Land allocation is given in three decimal places because truncating to one decimal place would over-estimate the size of land area under each crop

4.2.2.7 Effect of increasing fertilizer prices on deforestation

Withdrawal of fertilizer subsidy has been widely used by the World Bank as one important component in its recommendations in the ongoing process of structural adjustment (FAO 1991). Implementation of this recommendation increases the price of fertilizer (Sankhayan & Øygard 1993). In order to investigate the effect of decontrolling the price of inputs particularly fertilizer on the model results, the fertilizer price was increased up to double the price. The existing fertilizer price was increased by 5, 10, 15, 50 and 100 percent and the optimum farm plans following this increase are presented in table 4.37. The model results show that, increase in fertilizer price did not reduce the current level of fertilizer use. The explanation is that the marginal income of increased fertilizer use is higher than the marginal cost of the fertilizer. Also the current levels of fertilizer use are below the optimum level. As expected and as confirmed by the model, increasing fertilizer price significantly reduced the total net income for the household from T.Shs. 282800 per year in the basic farm plan to T.Shs. 281800, 280820, 279830, 272890 and 262990 per year for increase in fertilizer price of 5%, 10%, 15%, 50% and 100% respectively.

Profitability of farming is therefore governed by, among other things, the cost of inputs such as fertilizer. Other things referred to here include: crop response to fertilizer, producer prices and marketing services, and the demand elasticity of the crop in question. Increasing the price of inputs such as fertilizer will further impoverish the already ruined farmers and this negatively affects the environment. The reason is that, when farmers have no access or cannot afford to buy fertilizer, decline of crop harvest is enhanced. In consequence, farmers continue with "mining" the soil which is already infertile especially on marginal lands. Moreover, they may try to compensate a decline in crop productivity by clearing forest to acquire fresh land. On the other hand, if productivity of the land is enhanced by access to fertilizer, the need to expand by forest clearing is reduced because the land already under cultivation can yield more crop to support a larger population. Under conditions of high land productivity labour also becomes a limiting factor because of intensification of farm activities. The tendency to expand farmland will be reduced even if the opportunity cost of forest land bordering to the cultivated land is increased by other actions such as direct investments in agriculture, intensified extension services to the farmers and provision of better roads in rural areas as pointed out by Hansen (1994).

He observes that when the productivity of cultivated land goes up, so does the opportunity cost of forested land bordering to the cultivated land. As a result, he points out, it becomes more tempting to clear more land (i.e. deforest) compared to retaining the forest in its pristine state. In the Nguru mountains, if access to fertilizer and other inputs is improved, farmers are not likely to clear the forest because of the relative costs of land clearing and elasticity of non-family farm labour supply versus intensification and conservation of forest and already cultivated land. About T.Shs. 25000 are required as additional working capital to clear one hectare of forest land. Moreover, households depend entirely on family labour because they cannot afford to hire labour. Besides, efforts by the forest extension service and forest law enforcement both aim at preventing forest clearing or conversion to other uses.

Table 4.37 Optimum farm plans for a household in Mhonda village when fertilizer price increases by 5, 10, 15, 50 and 100 percent

Item/resource use	Basic optimum farm plan	Optimum farm plans at fertilizer price increase of				
		5 %	10 %	15 %	50%	100%
Max inc.(T.Shs./year)	282800	281800	280820	279830	272890	262990
Min SDI (T.Shs.)	195590	195590	195590	195590	195590	195590
Min SDL (ME-mandays)	4.43	4.43	4.43	4.43	4.43	4.43
Land alloc. (ha) ² :						
Monocropping						
MSRU	0	0	0	0	0	0
MLRU	0	0	0	0	0	0
BSRU	0	0	0	0	0	0
BLRU	0.025	0.025	0.025	0.025	0.025	0.025
Cassava	0	0	0	0	0	0
Rice	0.087	0.087	0.087	0.087	0.087	0.087
Sorghum	0	0	0	0	0	0
Vegetable	0.500	0.500	0.500	0.500	0.500	0.500
Mixed cropping						
SRM/B	0	0	0	0	0	0
LRM/B	0.261	0.261	0.261	0.261	0.261	0.261
Maize/Sorghum	0.031	0.030	0.030	0.030	0.031	0.031
Cassava/Beans	0.809	0.809	0.809	0.809	0.809	0.809
M/B/C/S	0.083	0.083	0.083	0.083	0.083	0.083
Banana/Cassava	0.090	0.090	0.090	0.090	0.090	0.090
Fruit/Cassava	0.131	0.131	0.131	0.131	0.131	0.131
Minor crops	0.100	0.100	0.100	0.100	0.100	0.100
Multiple cropping						
Maize/Beans	0.382	0.382	0.382	0.382	0.382	0.382
Beans	0	0	0	0	0	0
Tot. cultivated land	2.5	2.5	2.5	2.5	2.5	2.5
Fertilizer nutr.(kg):						
Nitrogen	101	101	101	101	101	101
Phosphorus	41	41	41	41	41	42
Working capit. (T.Shs.)	77887	77887	77887	77887	77887	77887
Food consumption (kg):						
Maize	794	794	794	794	794	794
Beans	506	506	506	506	506	506
Cassava	2402	2401	2401	2401	2402	654
Rice	131	131	131	131	131	131
Sorghum	69	69	69	69	69	69
Vegetable	600	600	600	600	600	600
Banana	108	108	108	108	108	108
Fruit	46	46	46	46	46	46
Minor crops	5	5	5	5	5	5

Source: Model results

Footnote:(1) Assuming same farming technology will prevail over the entire period hence inputs remain the same.

(2) Land allocation is given in three decimal places because truncating to one decimal place would over-estimate the size of land area under each crop

Empirical evidence during the survey in Mhonda village indicated that, the effect of not clearing the forest if land productivity was improved is higher than the tendency to clear it because even at the present low levels of crop productivity, farm expansion by forest clearing is done out of necessity to survive, because it is perceived as an arduous task which most people would wish to avoid if the economic situation would allow them.

4.2.2.8 Stochastic analysis of optimum farm plans in Mhonda village

Effect of risk aversion on deforestation

During experimentation with stochastic variables the quadratic model was used to compute efficient compromise solutions using L_1 , L_2 and L_∞ metrics. In five different scenarios, subjective weights were assigned to the three objectives being compromised as described in section 3.2.2.16. The pay-off matrix showing the ideal point for the basic scenario is presented in table 4.28. The L_1 , L_2 and L_∞ metrics optimum compromise solutions for the base scenario are presented in table 4.29. The results of sensitivity analysis for various scenarios are presented in tables 4.38, 4.39 and 4.40. A couple of observations can be made from these results. By assigning equal weight to the three objectives, a lower income is obtained at high risk level. On the other hand, a higher income is obtained by assigning more weight to maximization of income than the other objectives but this is realized at a higher level of risk. By assigning more weight to minimization of risk and labour use variation, a lower income is realized but at a lower level of risk. A farmer must therefore trade-off by choosing either low income at a low level of risk and labour use variation or a high income at a corresponding high level of risk and labour use variation. With regard to deforestation pressure, assigning more weight to maximization of income relative to the other objectives causes increased pressure for deforestation as it promotes the need for forest clearing to expand farmland in order to increase crop yield for sale. However, assigning more weight to minimization of risk and labour use variation has the effect of reducing pressure for deforestation but at the expense of income which also declines. By assigning more weight to risk minimization the, the farmer perceives risk in farming to increase and under such circumstances, it may not be unappealing to expand farmland through forest clearing because expected income is low. The choice of an efficient farm plan from the best compromise set remains the responsibility of the farmer depending on preference between expected income and risk as defined by the farmer's E-V utility function. Through assigning weights to the different objectives, the farmer expresses his preference. Since assigning more weight to either maximization of income or minimization of risk meets subsistence requirements, an income-minded farmer would choose a farm plan that maximizes income even though at a high risk level in order to increase his capacity to buy market goods and meet other cash-requiring obligations. Since this may be achieved through forest clearing it is undesirable because it may promote deforestation. On the other hand, a risk averse farmer would choose to produce only enough for his family and generate income from off-farm activities if opportunities exist. This has positive impact on deforestation. However, the choice still lies on the farmer based on the prevailing circumstances. Often peasants are faced with limited options for off-farm activities due to poverty and ignorance and consequently may sometimes be compelled to take risks for the sake of subsistence and income as a matter of survival. Thus even under increasing risk, they may still undertake farming even if it means

clearing the forest to cause deforestation. Other social factors often also contribute to this decision of farming even when risk is perceived to increase.

Table 4.38 Compromise farm plans corresponding to L_1 metric when objective weights are varied for a farm household in Mhonda village

Level of variable/objective function value ¹	Optimal farm plan	Optimal Compromise farm plans for L_1				
		1:1:1	5:1:1	1:5:1	1:1:5	1:5:5
Max income(T.Shs./year)	282800	150060	163800	150060	150060	150060
Min SDI (T.Shs.)	195590	112934	113745	112934	112934	112934
Min SDL (ME-mandays)	4.43	-	-	-	-	-
Land allocation (ha) ² :						
Monocropping						
MSRU	0	0	0	0	0	0
MLRU	0	0.565	0.105	0.565	0.565	0.565
BSRU	0	0	0	0	0	0
BLRU	0.025	0.399	0.047	0.399	0.399	0.399
Cassava	0	0	0	0	0	0
Rice	0.087	0.087	0.087	0.087	0.087	0.087
Sorghum	0	0	0	0	0	0
Vegetable	0.500	0.500	0.500	0.500	0.500	0.500
Mixed cropping						
SRM/B	0	0	0	0	0	0
LRM/B	0.261	0	0.524	0	0	0
Maize/Sorghum	0.031	0.008	0.092	0.008	0.008	0.008
Cassava/Beans	0.809	0.025	0.115	0.025	0.025	0.025
M/B/C/S	0.083	0.115	0	0.115	0.115	0.115
Banana/Cassava	0.090	0.090	0.090	0.090	0.090	0.090
Fruit/Cassava	0.131	0.131	0.131	0.131	0.131	0.131
Minor crops	0.100	0.100	0.100	0.100	0.100	0.100
Multiple cropping						
Maize/Beans	0.382	0	0	0	0	0
Beans	0	0.413	0.413	0.413	0.413	0.413
Total cultivated land	2.5	2.43	2.2	2.4	2.43	2.43
Fertilizer nutr.(kg):						
Nitrogen	101	99	100	99	99	99
Phosphorus	41	56	50	56	56	56
Working capit. (T.Shs.)	77887	81418	76220	81418	81418	81418
Food consumption (kg):						
Maize	794	794	794	794	794	794
Beans	506	506	506	506	506	506
Cassava	2402	654	654	654	654	654
Rice	131	131	131	131	131	131
Sorghum	69	69	69	69	69	69
Vegetable	600	600	600	600	600	600
Banana	108	108	108	108	108	108
Fruit	46	46	46	46	46	46
Minor crops	5	5	5	5	5	5

Source: Model results and own field data

Footnote: (1) Symbols remain as defined earlier

(2) Land allocation is given in three decimal places because truncating to one decimal place would over-estimate the size of land area under each crop

Table 4.39 Compromise farm plans corresponding to L_2 metric when objective weights are varied for a farm household in Mhonda village

Level of variable/objective function value ¹	Optimal farm plan	Optimal Compromise farm plans for L_2				
		1:1:1	5:1:1	1:5:1	1:1:5	1:5:5
Max income(T.Shs./year)	282800	282460	282730	281440	282460	281440
Min SDI (T.Shs.)	195590	196465	195761	199109	196465	199109
Min SDL (ME-mandays)	4.43	-	-	-	-	-
Land allocation (ha) ² :						
Monocropping						
MSRU	0	0	0	0	0	0
MLRU	0	0	0	0	0	0
BSRU	0	0.013	0.003	0.052	0.013	0.052
BLRU	0.025	0.019	0.024	0.001	0.019	0.001
Cassava	0	0	0	0	0	0
Rice	0.087	0.087	0.087	0.087	0.087	0.087
Sorghum	0	0	0	0	0	0
Vegetable	0.500	0.500	0.500	0.500	0.500	0.500
Mixed cropping						
SRM/B	0	0	0	0	0	0
LRM/B	0.261	0.253	0.259	0.230	0.253	0.230
Maize/Sorghum	0.031	0.036	0.032	0.052	0.036	0.052
Cassava/Beans	0.809	0.817	0.811	0.841	0.817	0.841
M/B/C/S	0.083	0.076	0.082	0.054	0.076	0.054
Banana/Cassava	0.090	0.090	0.090	0.090	0.090	0.090
Fruit/Cassava	0.131	0.131	0.131	0.131	0.131	0.131
Minor crops	0.100	0.100	0.100	0.100	0.100	0.100
Multiple cropping						
Maize/Beans	0.382	0	0.383	0.413	0	0.413
Beans	0	0.389	0	0	0.389	0
Total cultivated land	2.5	2.5	2.5	2.55	2.5	2.55
Fertilizer nutr.(kg):						
Nitrogen	101	101	101	101	101	101
Phosphorus	41	41	41	42	41	42
Working capit. (T.Shs.)	77887	78246	77957	79330	78246	79330
Food consumption (kg):						
Maize	794	794	794	794	794	794
Beans	506	506	506	506	506	506
Cassava	2402	2407	2403	2422	2407	2421
Rice	131	131	131	131	131	131
Sorghum	69	69	69	69	69	69
Vegetable	600	600	600	600	600	600
Banana	108	108	108	108	108	108
Fruit	46	46	46	46	46	46
Minor crops	5	5	5	5	5	5

Source: Model results and own field data

Footnote: (1) Symbols remain as defined earlier

(2) Land allocation is given in three decimal places because truncating to one decimal place would overestimate the size of land area under each crop

Table 4.40 Compromise farm plans corresponding to L_{∞} metric when objective weights are varied for a farm household in Mhonda village

Level of variable/objective function value ¹	Optimal farm plan	Optimal Compromise farm plans for L_{∞}				
		1:1:1	5:1:1	1:5:1	1:1:5	1:5:5
Max income(T.Shs./year)	282800	282800	150060	150060	150060	150060
Min SDI (T.Shs.)	195590	165980	112934	112934	112934	112934
Min SDL (ME-mandays)	4.43	-	-	-	-	-
Land allocation (ha) ² :						
Monocropping						
MSRU	0	0	0	0	0	0
MLRU	0	0.205	0.565	0.565	0.565	0.565
BSRU	0	0	0	0	0	0
BLRU	0.025	0.023	0.399	0.399	0.399	0.399
Cassava	0	0	0	0	0	0
Rice	0.087	0.700	0.087	0.087	0.087	0.087
Sorghum	0	0	0	0	0	0
Vegetable	0.500	0.500	0.500	0.500	0.500	0.500
Mixed cropping						
SRM/B	0	0	0	0	0	0
LRM/B	0.261	0.961	0	0	0	0
Maize/Sorghum	0.031	0.092	0.008	0.008	0.008	0.008
Cassava/Beans	0.809	0.198	0.025	0.025	0.025	0.025
M/B/C/S	0.083	0	0.115	0.115	0.115	0.115
Banana/Cassava	0.090	0.090	0.090	0.090	0.090	0.090
Fruit/Cassava	0.131	0.131	0.131	0.131	0.131	0.131
Minor crops	0.100	0.100	0.100	0.100	0.100	0.100
Multiple cropping						
Maize/Beans	0.382	0	0	0	0	0
Beans	0	0	0.413	0.413	0.413	0.413
Total cultivated land	2.5	3.0	2.43	2.43	2.43	2.43
Fertilizer nutr.(kg):						
Nitrogen	101	173	99	99	99	99
Phosphorus	41	80	56	56	56	56
Working capit. (T.Shs.)	77887	102860	81418	81418	81418	81418
Food consumption (kg):						
Maize	794	794	794	794	794	794
Beans	506	506	506	506	506	506
Cassava	2402	845	654	654	654	654
Rice	131	131	131	131	131	131
Sorghum	69	69	69	69	69	69
Vegetable	600	600	600	600	600	600
Banana	108	108	108	108	108	108
Fruit	46	46	46	46	46	46
Minor crops	5	5	5	5	5	5

Source: Model results and own field data

Footnote: (1) Symbols remain as defined earlier

(2) Land allocation is given in three decimal places because truncating to one decimal place would over-estimate the size of land area under each crop

5.0 OVERALL DISCUSSIONS AND CONCLUSIONS

This study is based on the premise that analyzing agriculture and forest relations in the context of welfare and peasant household economics is a powerful tool for understanding how and why peasant activities degrade the environment particularly the soil, forests and woodlands. Such analysis is essential for developing policy recommendations to bring about sustainable use of resources. The reason for this point of view is that peasant farmers in a developing country like Tanzania represent a link between the economy and ecology and thus environmental balance is closely linked to the way peasants manage and utilize land resources. In this way therefore the main hypothesis of this study is legitimized. This hypothesis envision that improving peasant economy in the Nguru mountains would help peasants to improve their standard of living and hence adopt more appropriate landuse practices than today. This in consequence would lead to reduced pressure on forest lands and thus would contribute positively to protection of the forests.

The main contention in this hypothesis is that poverty is one reason compelling peasant farmers to practice poor landuse practices which degrade woodlands and forests. Since agriculture is the main economic activity among the people its improvement is synonymous with improving people's welfare. This would lead to improvement of farming practices and better use of resources hence would reduce a threat to forest lands. The study therefore has analyzed the farming systems and their relationships with forest lands in a selected village in the Nguru mountains. It also investigated the prospects for sustainable management of resources in order to avert the threat to the rainforest and woodlands in the area. The analysis led to the following discussions and conclusions.

5.1 Resources availability consequences under the existing farming practices

5.1.1 Land supply and its effects on deforestation

Survey results showed that an average household depends on about 2.5 ha of farmland for its subsistence. In the compromise farm plans some crop enterprises are eliminated and yet all the land is utilized in the production cycle in order to meet minimum consumption needs. The fact that all available land has to be used in order to meet household subsistence imply that land is inadequate. The scarcity of land is also reflected in the fairly high existing farm price (T.Shs. 25000 per hectare) in an environment where people are poor and land markets are not well developed due to customary laws and other impediments. The observed average price of land would be even higher if land markets were fully developed. Forest encroachment observed in the village besides its role as a compensating mechanism for declining crop productivity due to loss in soil fertility, it serves as a reflection of existing desire for additional land.

The basic model developed in this study, shows a low shadow price of land implying that land is not limiting. The actual fact is that land is limiting. The basic model being static cannot reveal the role of land as a capital asset and as a means of raising the productivity of labour in subsequent years. With the emerging land markets the shadow price of land in the static model

will become even lower than observed average land price. It is remarkable that an average household with 3.9 ME of labour and 5 consumption units can meet its subsistence when it has an inadequate average farm size of 2.5 ha. Cultivation of perennial crops particularly cash crops would be an added advantage for cash generation to meet cash requiring obligations. In order to improve the productivity of labour and capital an average household has to improve farming methods or to increase the size of the farm. However, farm expansion and land purchase like adoption of new farming methods are extremely costly beyond the cash outlay ability for most average households. The farmer lacks capital to buy land or to transform agriculture while land clearing is also costly and undesirable because it causes deforestation. This puts a farmer in a dilemma. However, to the farmer, farm expansion stands as a relatively easier option where it is feasible in terms of availability of land for expansion. Thus farm expansion is considered by peasant farmers as an important and worthwhile investment which due to its arduous nature often takes place in stages.

A cost-benefit analysis of the expansion of holdings by land clearing revealed that farmers can and do make considerable gains from expansions, the undesirable impacts on forest cover notwithstanding. Smaller farms were found to earn highest additional net income. A farmer who decides to expand his farm holding to 1 ha for growing a mixture of Maize, beans, cassava and sorghum, invests an equivalent of T.Shs. 25000 in terms of foregone immediate consumption. In the following year, however, this farmer can operate on an outer revenue curve and gains T.Shs. 43931 extra income as a result of last year's farm expansion. The net benefit accruing as a result of the expansion only in the first year is T.Shs. 18931. The accumulated discounted net gain (at 6% discount rate) in 10 years for this farmer is T.Shs. 105710. The same benefits could accrue to the farmer who has no farmholding and decides to establish 1 ha of the same mixture of crops. But the latter would break-even much faster than the former. Also the latter makes bigger gains than the former because of labour availability to the latter and low opportunity cost of labour.

On the whole therefore, expansion of the farmholding is the most profitable and necessary on small farms to compensate for the inadequate farm size and declining crop productivity due to the loss in soil fertility. However, expansion becomes less profitable and it takes much longer for the costs to be recovered in relatively big farms where the shadow price of land is lower or close to zero. Unfortunately, land shortage in public lands due to population growth do not give many households possibilities to expand farm holdings and move to higher productivity levels. Moreover, the capital costs involved sometimes deter some households from engaging in such activity. However, most peasant farmers would prefer to expand particularly by invading forest lands which are wrongly perceived to be more fertile than other lands. In spite of the arduous task involved in new land clearing, the lack of substantial investment in manure on presently cultivated land, and the belief that forest soils are more fertile, puts many of the farmers in a situation where they find expansion the only way to raise productivity and hence income. This increases deforestation pressure. The opportunity to improve productivity by intensification seems an infeasible option for most households in a dilapidated (ruined) condition. However, land shortage and inability to expand will in the long run leave intensification as the only viable option in the interest of farmer's welfare and the environment. This brings us to capital supply as another important resource limiting productivity in peasant farming.

5.1.2 Capital supply effect and deforestation

The lack of capital limits the extent to which land and labour can be utilized. Normative analysis showed that increasing capital supplies raised both incomes and resources productivities. Production theory asserts that capital has the effect of raising the average productivity of factors through an outward shift of the production function due to technology improvement (Dornbusch & Fischer 1990). Since the improved technology considered here are all intensive or land saving, higher capital supplies would lead to lower demand on farm area expansion. In view of the increasing land shortage, a strategy of raising productivity by intensification rather than expansion is desirable because it reduces deforestation by land clearing. Survey results in Mhonda village showed that clearly operational capital is deficient on the average farm household as reflected by the dilapidated life style, poor agricultural implements used and also by farmer's inability to purchase inputs besides meeting essential cash obligations. On the average, a household is estimated to have an annual net cash flow of T.Shs. 3000 for financing farm operations and to meet essential cash obligations. The low net cash flow reflects that most of the capital is tied up in implements and stocks of inputs hence subsistence nature of the economy, low liquidity, low cash balances and low marketing of farm output.

This explains why despite the farmer's awareness of extension's message to improve farming practices and deriving from the model's results that they should embark on improved technologies, farmers have adhered to their traditional methods giving low yields. Farmers might be rational in resisting improved methods because given the present low level of operational capital, it is infeasible and may be suicidal to embark on the improved technologies. Traditional methods have prevailed because of their modest capital requirement. However, at high capital supply levels, improved crop husbandry practices would become more superior to traditional methods as asserted by the model results. This concurs with the hypothesis that adoption of improved technological innovations is hampered by lack of capital to meet the necessary cash outlays.

It can be concluded that with capital available, it is efficient to operate at higher technological levels and vice versa. For analytical purposes it can be concluded that as capital supply improves, the shadow price of capital declines progressively. This level of the shadow price of capital, show the maximum amount of capital that a farmer can put to profitable engagement under the current technology. Beyond this, additional operational capital cannot pay the interest rate. Labour shortage set in as a limiting factor and the situation can only be improved by adopting labour saving technology. In this sense therefore the value of shadow price of capital can be used as a proxy to judge at what interest rate farmers would be willing to borrow money. When this is very high it implies the dire need for additional capital to improve farming practices.

Another conclusion is that raising farmer's incomes by producer price incentives would lead to increased investment into farming as it would be profitable to do so. This is very important in that it will promote intensification rather than expansion and thus has a bearing to reducing forest and woodland conversion. Currently an average farm household in Mhonda village spends about 2 percent of its total income on farm investments. It is reasonable to assume that this

investment rate would be maintained or even could be increased as farm incomes improve. Therefore offering remunerative producer prices is one possible way to mitigate or surmount the problem of capital shortage.

In the context of this study therefore capital supply assumes a crucial role in bringing desired long-term agricultural improvement which is conceived can take place in two stages. In the short term farm productivity can be achieved using relatively little additional resources provided some institutional impediments to agriculture such as land tenure constraints, traditional imperfections, marketing and input distribution inefficiencies and low producer prices are removed. However, in the long-term substantial increases in productivity can only be achieved through technological improvement involving more use of capital resources. The basic premise of the second view point is that long-term changes need large capital expenditures and consequently capital becomes the most scarce resource limiting the extent to which both labour and land can be utilized.

The main effect of lack of working capital on deforestation is that farmers cannot purchase agricultural inputs and hence adopt poor farming practices and compensate decline in crop productivity on marginal lands by forest encroachment to acquire fresh land. It is estimated that 60 % of the deforestation in developing countries is a result of agricultural expansion (World Bank 1992). In the African context, 50 % of the food production increase is derived from expansion of the cultivated area (Hansen 1994). This may be in woodlands or in the tropical rainforest. The slash-and-burn technique practiced is associated with low yields and mining of existing forest and soil resources. Technologies which can improve farmer's productivity may help to relieve poverty and reduce pressure on forest lands. A policy which facilitates credit to farmers or subsidizing of inputs such as fertilizer can generate local employment, promote the degree of food self-sufficiency and reduce the pressure on forest lands.

5.1.3 Labour supply effects and deforestation.

The analysis of labour supply in households showed that there are around 3.9 ME of labour to support 5 consumer units. Thus the resultant dependency burden is 1 adult unit to 1.3 mouths to feed. This dependency burden suggests high consumption rates which may have led to low savings whose consequence is minimal investment in agriculture and hence adoption of poor landuse practices. The fact that productivity is declining in an environment where there is dependency burden, implies that living standards are falling. Therefore per capital food consumption have not remained constant due to family size increase. This decline have caused deterioration of the family labour force.

Nonetheless the model results still portray that, under the existing technology, capital supply and farm size, labour is not a constraint. Thus it can be asserted that time mismanagement such as excessive leisure still consumes a significant proportion of daylight time. Farm expansion is one way to engage free labour in productivity. Another way is to activate labour into other non-farm economic activities. By far farming still remains the dominant economic activity. An analysis by the model has shown that through farming activities, households are able to meet their subsistence needs and earn some income. Assuming the farmer finds these returns appealing, it

would be reasonable to increase labour input by reducing leisure and by attending labour diverting factors such as ill-health, social activities and domestic chores. The need to have full employment of labour requires keeping excess labour requirement at a minimum during busy times and to have enough work to keep all labour occupied during slack periods. This could boost production. The effect of labour supply on deforestation may be partly attributed to farmer's unwillingness to engage in the arduous task of forest clearing. Forest clearing to expand farms is done out of necessity for survival and consequently limited to clearing only the necessary portion of land. Coupled with poor working tools and other constraints such as ill-health and gender division of forest clearing tasks, deforestation rate is somewhat checked by labour related shortcomings.

5.2 Impact of land use practices on deforestation

Land is a highly valuable resource in Mhonda village because the household has to derive its subsistence from it. Cost-benefit analysis of land clearing showed that the first few units of land are usually highly valuable. Due to the loss in soil fertility resulting in declining productivity of land which is also inadequate the household food supply has also been uncertain and declining. Therefore households have been forced to devise other methods of fulfilling their caloric requirements. Since most households are unable to purchase food from the market due to lack of money and high prices of food on the market, households compensate these deficiencies by new land clearing to expand farm size and to acquire fertile land. This expansion was observed to be done in the woodlands and forests hence resulting in either degradation or deforestation. The model results indicate that a substantial area is cleared per annum hence threatening the future of forest lands in the area particularly if it is considered that population will continue to grow and economic activity will continue to increase.

Since new land clearing has been observed in this study to be beneficial at least in the initial years it will continue to be the source of deforestation in the area unless agricultural transformation take place to improve farming techniques so that yield increases are brought by intensification instead of farm expansion. Thus in view of land shortage and decline in soil fertility and hence productivity, a strategy of increasing production through intensification rather than expansion is more appealing and the only alternative in the long-term if environmental degradation is to be averted. The improved technologies considered here must, unlike the current practices, be land saving (intensive rather than extensive) and must conserve the soil and maintain its fertility. These however need capital investment which must be availed to farmers by external intervention or farmers themselves must raise it through their own savings. However, besides supplying capital to intensify agriculture the effort to reduce pressure on the tropical rain forest and woodland resources must be supplemented by improvement in other agricultural services to promote crop output and thus raise peasants incomes and savings which could be ploughed back to improve farming. This is an essential step for the effect of available capital to be felt.

Due to limited capital supply and contrary to Boserup's theory, farmers in Mhonda village have chosen to expand their farms through land clearing as a strategy to increase crop production instead of intensification of agriculture. Possibilities for intensification are further curtailed by

existing institutional impediments to agricultural development. The people recognize the need to improve farming practices but they lack the means to do so and for the sake of survival they have chosen to engage in land use practices that degrade the environment. Under such circumstances low cost intensive production methods to improve or transform the existing farming systems are essential. Moreover the real cost of crop production must be reflected in crop producer prices if inefficiencies in production are to be removed and improve resource allocation.

5.3 Returns and profitability of cropping patterns

Under the existing cropping patterns, cassava, vegetable and rice were most profitable under monoculture cropping. However, mixed cropping of maize, beans, cassava and sorghum gave the highest returns. Thus besides yielding highest returns, mixed cropping enterprise is more appealing to farmers because by intercropping several crops it caters for diversification which facilitates risk aversion. According to the results of this study the micro-economic analysis showed that the current use of resources is profitable as shown by the positive returns obtained from the factors of production and cropping enterprises. However, more benefits could be achieved if the existing farming practices and marketing conditions improved. Based on the comparison between the existing farm plan and the compromise production plans it can be concluded that, subject to institutional imperfections which impede them and over-diversification to avert risk, peasants still have possibilities to improve profitability of cropping enterprises through allocative efficiency. The reason for this conclusion is that the actual production plan shows a wider diversity of crop production activities than the optimal production plans. This implies that the resources which are currently used to service a wide diversity of crop enterprises could be concentrated on only few most profitable activities as identified by the model. This emphasizes the need to specialize in profitable enterprises if farmers are to maximize their incomes.

Labour use improvement and regulating risk behaviour are other areas that could be used to raise productivity. The study results show that working habits/traditions under present levels of farming technology leave plenty of labour underutilized. Limited involvement in economic activities of household members is another cause for underutilization of household labour. The division of labour between sexes when practiced overburden one sex while another enjoy leisure in some activities. Social values and beliefs also divert labour and other resources from production hence reduce incomes. Traditional aversion of risk have led to great diversification of farm enterprises thus trading efficiency for flexibility. The basic model results confirm labour under-utilization below its maximum supply level. Similarly limited access to off-farm employment have denied households the chance to raise revenues which could be saved for investment in agriculture. This however depends also on other factors internal to the household such as producer-consumer ratio, size of male labour force and so forth. Heavy dependency on loans which are neither guaranteed nor forthcoming is also an impediment to agricultural transformation in Mhonda village. Thus there is still room to improve productivity by mobilizing idle resources into production activities. This leads to the conclusion that resource mismanagement and underutilization need to be rectified in order to improve profitability of cropping patterns. Moreover technological limitations which set a ceiling on productivity improvement must be tackled simultaneously with other

impediments if agricultural transformation is to be achieved. The reliance on the hand hoe, use of low yielding seed varieties and soil erosion control measures are among the issues to be addressed.

5.4 Population growth and sustainability of existing farming systems

Under the current population growth rate of 2.6 percent the existing farming systems in Mhonda village are not sustainable in the long-term beyond 15 years. They are sustainable at least only in the-short term whose cut-off period lies between 10 and 15 years. This is a very short time which signals a bleak future for farmers in Mhonda village if population continues to grow at the present rate unabated and without institutional reforms to improve agriculture.

In the context of this study it is asserted that there exist possibilities for peasant farmers in Mhonda village to make short-term agricultural gains in output through resource re-allocation and low capital intensive farming methods. However, such short-term gains are not enough to cater for the long- term anticipated population growth. Thus in the long-term, the existing farming systems cannot sustain the current population growth rate unless capital investment is made to improve farming technology to higher yielding farming techniques. Therefore a more fundamental transformation of peasant agriculture is needed and this can only be achieved through increased use of capital to bring about sustainable technological improvements, to raise productivity and to bring about advancement in general economy of the area.

Since capital supply is constrained by institutional impediments there is enough ground to conclude that institutional imperfections which impede agricultural performance and jeopardize the possibility of the existing farming systems to support the growing population must be removed. Their removal is an essential prerequisite to transforming agriculture. For example poor marketing services have compelled farmers to abandon or neglect cash crop production despite the high potential for such crops in raising farmer's incomes which could be used to improve farming. Low producer prices on the other hand have reduced farmer's ability to recoup the investment costs hence rendering farming less profitable than it would be if higher prices were to be offered. Sometimes farmers crops have not been bought by crop authorities hence nullifying the need to produce cash crops not directly consumed by the household.

5.5 Effect of risk aversion and labour use variability on land use pattern and deforestation

In this study minimization of risk and labour use variation were among the objective functions modelled. The reason being that farmers performance in Mhonda village is influenced by various risks and labour use seasonality. The risks considered here are those associated with variation in crop yields and product price hence farmers income. Risk aversion requires minimization or total avoidance of risk. The desire for a high income level is reflected by the maximization of gross margin which is a contribution to the fixed cost and profit. However, when farmers operate under conditions of risk aversion, then they must expect low incomes as asserted by the model results since these objectives are conflicting. The overall decision criteria applied is that the farmer will accept an efficient farm plan with increased risk level only when the expected net cash income also increases.

Considering the biological nature of crop production, market variability of agricultural crops and seasonal variation of labour utilization of Mhonda village farmers it can be concluded that these factors partly influence the way farmers decide on their land use patterns. This has a strong bearing on farm size and type of crops or cropping patterns adopted. It also affects the way farmers react to external influences. In general farmers production decisions which have been seen to affect the environment and particularly forest land are influenced by such factors as asserted by model results. Thus it can be concluded that, controlling the risk level and labour seasonality would be an important step in mitigating some ecological problems caused by agriculture in the Nguru mountains particularly reduction of deforestation pressure.

5.6 General concluding remarks and policy implications of the study results

The direct agent of deforestation seems to be the conversion of land to other land uses, predominantly agriculture as a response to increases in human population and a complex of factors mainly poverty, policy and market failures, and macro-economic factors; most of which act with apparent synergistic effects and interconnectedness. Empirical evidence highlights the complexity of factors concerning population pressure and its links with agricultural extensification and intensification. This study takes the premise that deforestation is an inevitable consequence of social and economic development and needs to be controlled by increasing farm productivity and sustainability, and by concentrating the most intensive farming practices in the most fertile land. Improving agricultural productivity seems to be the core of any strategy to limit deforestation. This implies encouraging Boserupian intensification in the belief that this will displace the need for extensification and the conversion of the forest. This requires efforts in rural development, agricultural intensification and creating employment opportunities in rural areas in order to relieve the need for expansion into forests. Improving overall landuse policy and planning coupled with social and institutional strengthening are essential preconditions.

It has been found in this analysis that poverty and growing population in an environment of market and government failures are forces behind farmer's involvement in new land clearing activities which cause deforestation. The burgeoning population causes rising food demand. Unfortunately in the Nguru mountains there is decline of agricultural productivity due to loss in soil fertility. The decline in crop yields have caused low incomes hence denying peasant farmer's possibilities for agricultural intensification to promote use of smaller area for crop production. Therefore in the absence of possibilities for intensive farming due to lack of capital, peasant farmers compensate the effect of reduced productivity by farmland expansion through land clearing which takes place mainly in woodlands or forests. In Mhonda village expansion is by way of encroachment in the tropical rain forest. Thus peasant's main problem in Mhonda village centres on more land area and partly on limited factors of production. Consequently, any effort aimed at improving agricultural production and land use practices that affect forest lands must address decline in crop productivity. Thus measures aimed at conserving the soil and providing fertility to it seem more relevant to reduce the need for farm expansion and consequently forest encroachment, woodland degradation and deforestation. An integrated approach to land use practices in the Nguru mountains is a necessary step in stemming soil degradation whose secondary consequences include forest encroachment and degradation of woodlands.

Since low productivity and incomes have been established to be caused by limited mobilization and use of land and labour due to lack of capital and technology limitations, improvements in crop productivity and land use practices can take place in two stages. In the long term it must focus on raising physical productivity of land and labour through technological advancement involving a costly and painstaking process of adopting improved technologies which require heavy capital investment and rely heavily on external input. This means that, improved technological packages must be developed and subsequently be transferred to farmers by an efficient extension service. However, adoption of such technology requires farmers motivation by facilitating easy access to capital inputs. Low interest credit arrangements supplemented by remunerative producer price packages and marketing services improvement are indispensable in this regard. In the short and intermediate-term, it can be said that the proposed road to agricultural development which would reduce pressure on forest lands should not rely heavily on capital and imported inputs as these may be difficult to acquire in a country with foreign exchange shortage and many other priorities. Hence as mentioned above, opportunities to increase output through removal of institutional impediments, use of low capital intensive methods and low external input strategy, must be given more priority. Thus farmers must be motivated to increase use of inputs and adopt appropriate farming practices through efficient marketing services, producer price incentives, "incentive" goods and removing institutional agricultural-related impediments. Resource endowment of the area must be taken into account. These are necessary or crucial measures which could have positive externalities on environmentally-related land uses. For example, it was revealed by the basic model results that input to labour into farming could still be increased by reducing leisure and properly managing labour because at present level of technology labour is not fully employed. Fortunately economic forces such as food shortage due to declining productivity, presence of "incentive" goods and marketing opportunities have started to break tendencies of idleness and time mismanagement. The supply of farm labour can also be improved by introduction of general social welfare improvement programs such as health care, clean water supplies, improvement in infrastructure and household energy supplies.

It has been reported by Gibbon, Havnevik & Hermele (1993) that, lack or poor marketing services and low producer prices and lack of industrial commodities crippled Tanzania's agriculture in the 1980's. They give sufficient evidence, which is also evident from parametric analysis of increase in producer prices that once peasants of today have fulfilled their food needs, they will attempt to maximize income. Based on this, it is reasonable to believe that producer price incentives will improve farming practices by increasing possibilities for raising capital. Farmer's capital can be obtained from credit or from agriculture sector own savings. The latter source is more reliable. However, due to the peasant's high marginal propensity to consume caused by low average incomes and high dependency burdens it is unlikely that peasants can make sufficient savings for reinvestment in farming unless if better producer prices for their crops and off-farm employment opportunities give them some leverage. It has been shown that, due to growing population, declining crop productivity and shortened fallow periods, expansion of farms has become necessary. However, more labour and capital needed have set a limit to the size of expansion especially when large areas have to be opened. Again capital can play a crucial role in acquiring implements and hiring labour or in the long-term adopting labour saving power

technologies. However, main focus must be on the need to adopt technological packages that utilize relatively less capital inputs but give high yields. For example growing crops that can tolerate poor soils, resist pests and disease and adopting cheap methods of maintaining soil fertility and using biological and cultural techniques to control pests and diseases.

Reviving production of cash crops in the Nguru mountains is another way to raise farmer's incomes and hence improve land use practices which affect forest lands. Production of cash crops mainly cardamon, sugar cane, cotton, cocoa, tea and coffee at high altitudes has high potential to thrive well in the study area. However, such crops have been neglected due to institutional bottlenecks pointed above which have had more impact on cash crops because of the inelastic supply response of such crops in the short and intermediate term. Poor market services and undeveloped parallel market for these crops have encouraged farmers to neglect or abandon such crops. These being export crops and in view of Tanzania's need for foreign exchange, the involvement of farmers in these crops must be elicited by all means. Better policy instruments and incentives than coercion are more effective in eliciting farmer's involvement in cash crop production in the long term. Neglecting cash crops under prevailing conditions of low producer prices and poor market services may seem rational from a household's point of view but is catastrophic for the nation which relies on cash earnings from export of crops largely produced by smallholder farmers. Practicing agroforestry as an alternative technology to develop more sustainable cropping systems under condition of population growth is another way to increase farmer's incomes and to reduce the need for invading the forest in search of tree products. Although it is not analyzed in this study agroforestry has a potential and an inherent ability to increase fertilizer efficiency and to reduce dependency on chemical fertilizers. It is also a form of intensive use of land hence a cropping enterprise that increases carrying capacity of land (i.e. critical population density) by increasing productivity and hence profit. By increasing productivity of land it reduces the need for farm expansion hence would contribute positively to reducing deforestation pressure. However, further research is needed with respect to resilience of the land resources after a period of intensive use and long-term consequences of past and present farming practices.

Based on the existing constraints of peasant farming systems in the study area, normative behaviour strongly points towards elimination of some monocropping patterns if the existing economic and technological regime continues. There are strong indications that mixed cropping will continue to gain more importance in the household economy. This stresses the usefulness of diversification of farming in augmenting farm income and to avert risk. Rising fertilizer and other inputs prices as a result of inflation or withdrawal of subsidies will continue to reduce farmers net incomes. The impact of this on environmental degradation and deforestation is negative because by denying the farmers the possibility to use fertilizer and better farming implements they compensate decline in crop productivity by expansion of farmland. This process induces new land clearing and hence increases deforestation pressure. There exist economic incentives, as a response to poverty and government inaction to rectify poor policies, which compel peasant farmers to choose inappropriate landuse practices which are more extensive than the actual population density permits for sustainable practice. This is one main cause of deforestation. It also causes degradation of the soil resources to a lower production equilibrium

level. A careful and equitable economic policy based on an understanding of the incentive structure of the peasants is required to foster more sustainable land use practices. Such policy would be very useful in promoting conservation of forests and woodlands. There are good prospects for improving farmer's performance by minimization of risk and labour use variation as the model results show. Such a policy also favours the elimination of monocropping patterns and concentration on mixed cropping patterns in which legume crops such as beans increase soil fertility and diversified crops avert risk. The shift in cropping patterns to mixed cropping systems is less fertilizer intensive and environmentally friendly. Moreover, due to shift in cropping pattern, the pressure for family labour during the peak months, like risk, may somewhat be reduced. A close scrutiny of the existing plan suggest that, farmers are content with a lower level of income and operate at a low level of absolute risk (due to diversification in mixed cropping) but high level of labour use variation. Reconciling these objectives by approximations close to reality in compromise programming models as accomplished in this study and also improving productivity through allocative efficiency and agricultural transformation can serve the purpose of improving farmer's welfare and consequently reduce pressure on forest lands.

Regarding the multi-objective compromise programming model developed in this study, it may be a useful tool in technology evaluation. It permits judgement of technologies in a more holistic framework than simple analysis. It may be useful in developing efficient farm plans and agricultural policies within given socio-economic conditions. By permitting consideration of important socio-economic conditions, the model may simultaneously handle and weigh important constraints against each other for typical model households and thanks to improved computer technology that computations can be easily and quickly done. A farm planning model developed in this study for instance has facilitated the selection of the appropriate cropping pattern meeting the development objectives. Hence in so doing, the model may serve as a useful decision support system with positive impact on mitigating deforestation. The model may provide an efficient way of reproducing the farm reality and its responses to different external factors that affect the farmer's decision making process. Since farmers usually have conflicting objectives, the model illustrates that, there is a cost in emphasizing one objective in relation to others. The model provides possibility to quantify trade-offs between objectives. Nonetheless, this model still needs calibration with more accurate coefficients, needs updating and should be tested for its predictive power under various conditions. Inclusion of other stochastic variables may also be contemplated. There should also be a balance between complexity of the model and its operationality, because efforts to extend the model or to modify it to come much closer reality, may sacrifice its applicability. A balance must be met to ensure best or optimal decisions while recognizing that such decisions may not be the "best" for every particular state of nature, but rather may be robust across a wide range of conditions. The common point of view that models cannot replace the analytical power of the human brain from which they originate, still holds true. Thus the model developed here should only be used as a means to assist in decision making, because it can handle many variables in a consistent manner.

Among the shortcomings of this model are that the risk factors included, only relates to the crop yields and prices, the sources of risk that are manifest in the objective function as variability in gross margins for individual crop enterprises. This emphasis is due to the historical importance

technologies. However, main focus must be on the need to adopt technological packages that utilize relatively less capital inputs but give high yields. For example growing crops that can tolerate poor soils, resist pests and disease and adopting cheap methods of maintaining soil fertility and using biological and cultural techniques to control pests and diseases.

Reviving production of cash crops in the Nguru mountains is another way to raise farmer's incomes and hence improve land use practices which affect forest lands. Production of cash crops mainly cardamon, sugar cane, cotton, cocoa, tea and coffee at high altitudes has high potential to thrive well in the study area. However, such crops have been neglected due to institutional bottlenecks pointed above which have had more impact on cash crops because of the inelastic supply response of such crops in the short and intermediate term. Poor market services and undeveloped parallel market for these crops have encouraged farmers to neglect or abandon such crops. These being export crops and in view of Tanzania's need for foreign exchange, the involvement of farmers in these crops must be elicited by all means. Better policy instruments and incentives than coercion are more effective in eliciting farmer's involvement in cash crop production in the long term. Neglecting cash crops under prevailing conditions of low producer prices and poor market services may seem rational from a household's point of view but is catastrophic for the nation which relies on cash earnings from export of crops largely produced by smallholder farmers. Practicing agroforestry as an alternative technology to develop more sustainable cropping systems under condition of population growth is another way to increase farmer's incomes and to reduce the need for invading the forest in search of tree products. Although it is not analyzed in this study agroforestry has a potential and an inherent ability to increase fertilizer efficiency and to reduce dependency on chemical fertilizers. It is also a form of intensive use of land hence a cropping enterprise that increases carrying capacity of land (i.e. critical population density) by increasing productivity and hence profit. By increasing productivity of land it reduces the need for farm expansion hence would contribute positively to reducing deforestation pressure. However, further research is needed with respect to resilience of the land resources after a period of intensive use and long-term consequences of past and present farming practices.

Based on the existing constraints of peasant farming systems in the study area, normative behaviour strongly points towards elimination of some monocropping patterns if the existing economic and technological regime continues. There are strong indications that mixed cropping will continue to gain more importance in the household economy. This stresses the usefulness of diversification of farming in augmenting farm income and to avert risk. Rising fertilizer and other inputs prices as a result of inflation or withdrawal of subsidies will continue to reduce farmers net incomes. The impact of this on environmental degradation and deforestation is negative because by denying the farmers the possibility to use fertilizer and better farming implements they compensate decline in crop productivity by expansion of farmland. This process induces new land clearing and hence increases deforestation pressure. There exist economic incentives, as a response to poverty and government inaction to rectify poor policies, which compel peasant farmers to choose inappropriate landuse practices which are more extensive than the actual population density permits for sustainable practice. This is one main cause of deforestation. It also causes degradation of the soil resources to a lower production equilibrium

level. A careful and equitable economic policy based on an understanding of the incentive structure of the peasants is required to foster more sustainable land use practices. Such policy would be very useful in promoting conservation of forests and woodlands. There are good prospects for improving farmer's performance by minimization of risk and labour use variation as the model results show. Such a policy also favours the elimination of monocropping patterns and concentration on mixed cropping patterns in which legume crops such as beans increase soil fertility and diversified crops avert risk. The shift in cropping patterns to mixed cropping systems is less fertilizer intensive and environmentally friendly. Moreover, due to shift in cropping pattern, the pressure for family labour during the peak months, like risk, may somewhat be reduced. A close scrutiny of the existing plan suggest that, farmers are content with a lower level of income and operate at a low level of absolute risk (due to diversification in mixed cropping) but high level of labour use variation. Reconciling these objectives by approximations close to reality in compromise programming models as accomplished in this study and also improving productivity through allocative efficiency and agricultural transformation can serve the purpose of improving farmer's welfare and consequently reduce pressure on forest lands.

Regarding the multi-objective compromise programming model developed in this study, it may be a useful tool in technology evaluation. It permits judgement of technologies in a more holistic framework than simple analysis. It may be useful in developing efficient farm plans and agricultural policies within given socio-economic conditions. By permitting consideration of important socio-economic conditions, the model may simultaneously handle and weigh important constraints against each other for typical model households and thanks to improved computer technology that computations can be easily and quickly done. A farm planning model developed in this study for instance has facilitated the selection of the appropriate cropping pattern meeting the development objectives. Hence in so doing, the model may serve as a useful decision support system with positive impact on mitigating deforestation. The model may provide an efficient way of reproducing the farm reality and its responses to different external factors that affect the farmer's decision making process. Since farmers usually have conflicting objectives, the model illustrates that, there is a cost in emphasizing one objective in relation to others. The model provides possibility to quantify trade-offs between objectives. Nonetheless, this model still needs calibration with more accurate coefficients, needs updating and should be tested for its predictive power under various conditions. Inclusion of other stochastic variables may also be contemplated. There should also be a balance between complexity of the model and its operability, because efforts to extend the model or to modify it to come much closer reality, may sacrifice its applicability. A balance must be met to ensure best or optimal decisions while recognizing that such decisions may not be the "best" for every particular state of nature, but rather may be robust across a wide range of conditions. The common point of view that models cannot replace the analytical power of the human brain from which they originate, still holds true. Thus the model developed here should only be used as a means to assist in decision making, because it can handle many variables in a consistent manner.

Among the shortcomings of this model are that the risk factors included, only relates to the crop yields and prices, the sources of risk that are manifest in the objective function as variability in gross margins for individual crop enterprises. This emphasis is due to the historical importance

of both yield and price in agriculture, but does not mean that other sources of risk are unimportant. Other risks like natural or environmental hazards, changing demand, social uncertainty and changing government policies and actions which were not modelled, often affect households as risks in production, costs, resource usage and resource availability. The model also focused on accommodating risk in the objective function coefficients. It did not deal with risks that appear in the formulation as right hand side (RHS) parameters. For instance, by defining the programming model in particular ways, risk in water supplies or field time may appear as RHS parameters. Other model weaknesses may be caused by data paucity (i.e. limitation) in some variables and the fact that the assumptions made may sometimes be unrealistic. These notwithstanding, the model and experience gained in building and using it are important in improving the understanding of the problems of landuse planning and hence positively contribute to the decision making process to improve resource management and reduce deforestation pressure.

REFERENCES

- Ahlback, A.J. 1986. Industrial plantation forestry in Tanzania: facts, problems, challenges. Ministry of Natural Resources and Tourism, Planning Division, Dar es Salaam, 197 pp.
- Ahlback, A.J. 1988. Forestry for development in Tanzania. Swedish University of Agricultural Sciences, International Rural Development Center, Uppsala, Working Paper No. 71, 116 pp.
- Ahlback, A.J. 1992. Why and How to mobilize all rural people of Tanzania to tree planting. A Ph.D. thesis submitted to the Faculty of the Graduate School of the University of Minnesota. 408 pp.
- Barnum, H.N. & L. Squire 1979. A model of an agricultural household: Theory and evidence: Occasional Paper No.27. Washington D.C.: World Bank.
- Baumol, W.J. 1977. Economic theory and operations analysis. Fourth edition. Prentice-Hall International Series in Management, Englewood Cliffs, New Jersey, USA.
- Beets, W.C.1990. Raising and sustaining productivity of smallholder farming systems in the Tropics. A handbook of sustainable agricultural development. AgBé Publishing, Alkmaar, Holland. 738 pp.
- Bigegård, L.E. 1980. Manual for the analysis of rural underdevelopment. Rural Development Studies No. 7. Swedish University of Agricultural Sciences, IRDC, Uppsala.
- Binswanger, H.P. 1980. Attitudes toward risk: experimental measurement in rural India. *American Journal of Agricultural Economics*. ():395-407.
- Binswanger, H.P. and D.A. Sillers 1983. Risk aversion and credit constraints in farmer's decision making: A re-interpretation. *Journal of Development Studies* 20(1):5-21.
- Bjørndalen, J.E. 1991. Potential for sustainable management of the Tanzanian rain forests and their biota. Mimeo. Department of Forest Biology, Sokoine University of Agriculture, Morogoro, Tanzania. 61 pp.
- Bjørndalen, J.E. 1992. Tanzania's vanishing rain forests-assessment of nature conservation values, biodiversity and importance for water catchment. *Journal of Agriculture, Ecosystems and Environment*, 40:313-334.
- Bliss, C.J. & N.H. Stern 1982. Palanpur: The economy of an Indian village. Ch. 3, Oxford: Clarendon Press.
- Boisvert, R.N. and B. McCarl 1990. Agricultural risk modeling using mathematical programming. *Southern Cooperative Series, Bulletin No. 356*, 103 pp.
- Bojö, J. 1991. The economics of land degradation: Theory and applications to Lesotho. A dissertation for the Doctor's Degree in Economics. Stockholm School of Economics pp. 352.
- Boserup, E. 1965. The conditions of agricultural growth: the economics of agrarian change under population pressure. George Allen & Unwin Ltd, London, 124 pp.
- Boserup, E. 1990. Economic and demographic relationships in development. The Johns Hopkins University Press. Baltimore and London, p. 307.
- Boyd, H.K., R. Westfall, and S.F. Stasch 1981. Marketing research. In: Kessy J.F. Socio-economics and policy aspects of extending environmentally sound landuse techniques to the rural population. Unpublished M.Sc. dissertation AUN, Ås.

- Brooke, A., D. Kendrick, A. Meeraus 1992. GAMS a user's guide. Release 2.25. 289 pp.
- Bryceson, D.F. 1985. Food insecurity and the social division of labour in Tanzania, 1919-1985. Macmillan in association with St. Anthony's College, Oxford. 237 pp.
- Buijtenen, J.P van and W.W. Saitta 1972. Linear programming applied to the economic analysis of forest tree improvement. *J. For.* 70:164-167.
- Business Times Magazine, 1994. Business Times Magazine, Tanzania of July 29 - August 4, 1994. No. 300.
- Camm, B.M. 1962. Risk in vegetable production on a Fen farm. *Farm Economist* 10(2):89-98.
- Carlsson, B. 1981. Compendium on linear programming. SUAS, Department of Economics and Statistics, Uppsala.
- Casley, D.J. and D.A. Lury 1981. Data collection in developing countries. Oxford University Press. Oxford.
- Casley, D.J. and D.A. Lury 1982. Monitoring and evaluation of agriculture and rural development projects. A World Bank Publication. Johns Hopkins Press, Baltimore.
- Chambers, R. 1974. Managing rural development: ideas and experiences from East Africa. The Scandinavian Institute of African Studies.
- Chambers, R. 1983. Rural development: Putting the last first. Longman, Harlow.
- Chamshama, S.A.O.; V.R. Nsolomo & A. Persson 1990. Human impacts on the forest vegetation of the Nguru mountains, Tanzania. In: I. Hedberg & E. Persson (eds.). Research for conservation of the Tanzania catchment forests. Proceedings from a workshop/Seminar held in Morogoro, Tanzania, 13-17 March, 1989, Uppsala, pp. 150-154.
- Chayanov, A.V. 1966. The theory of a peasant economy. The American Economic Association, Illinois.
- Chillumba, S.N. 1984. Report on land use planning and soil conservation teaching carried about in Lindi region. Paper presented to the workshop on " Training on soil conservation in Tanzania", February/March, Nairobi, p. 149-158.
- Cohen, J.M. 1980. Land tenure and rural development in Africa. In: Bates & Lofschie eds. Agricultural Development in Africa: issues of Public Policy. Praeger Publishers, New York.
- Cohon, J.L. 1978. Multiobjective programming and planning. Academic Press, Inc. Harcourt Brace Jovanovich. San Diego. 333 pp.
- Collinson, M.P. 1972. Farm management in peasant agriculture: A handbook for rural development planning in Africa. Praeger Publishers Inc., New York.
- Coulson, A. 1981. Agricultural policies in mainland Tanzania, 1946-76. In: Heyer J., P. Roberts and G. Williams (eds.). Rural development in tropical Africa. Macmillan.
- Cox, M. L. 1972. A simplified approach to agricultural systems. International Agricultural Development Service (IADS); New York, Occasional paper.
- Daellenbach, H.G. and E.J. Bell 1970. User's guide to linear programming. Prentice-Hall, Inc. Englewood Cliffs, New Jersey. 226 pp.
- Daily News Newspaper, 1979. Daily News Newspaper, Tanzania, May 17, 1979.
- De Janvry, A. 1972. Optimal levels of fertilization under risk: the potential for corn and wheat fertilization under alternative price policies in Argentina. *American Journal of Agricultural Economics*, Vol. 54 No.1.

- Despotis, D.K. and J. Siskos 1992. Agricultural management using the ADELAIS multi-objective linear programming software: a case application. *Theory and Decision* 32:113-131.
- Dillon, J.L. and P.L. Scandizzo 1978. Risk attitudes of subsistence farmers in northeast Brazil: a sampling approach. *American Journal of Agricultural Economics*, 60(3):425-435.
- Dillon, J.I. and Hardaker I.B. 1980. Farm management research for small farmer development. *FAO Agricultural Services Bulletin* 41, FAO Rome.
- Dixon, J.A., R.A. Carpenter, L.A. Fallon, P.B. Sherman, and S. Manipomoke. 1986. Economic analysis of the environmental impacts of development projects. Earthscan Publications Limited, London, 134 pp.
- Dornbusch, R. and S. Fischer 1990. *Macroeconomics*. Fifth edition, McGraw-Hill Publishing Company pp. 301-344.
- Due, J.M., P. Anandajayasekeram, N.S. Mdoe and M. White 1984. Beans in the farming system in Langali and Kibaoni villages, Mgeta area, Morogoro Region, Tanzania. Economic Research Bureau (ERB), University of Dar es Salaam. ERB Paper No. 84.2, 46 pp.
- Dykstra, D.P. 1980. Food and nutrition: A preliminary mathematical programming analysis for an Ujamaa village in Tanzania. Proceedings, National seminar on agroforestry, Nairobi, Kenya. 12th-22nd Nov. 1980. 8 p.
- Dykstra, D.P. 1984. *Mathematical programming for natural resource management*. McGraw-Hill Book Company, New York. 318 pp.
- EIU, 1992. Tanzania, country profile 1992-1993. Annual survey of political and economic background. The Economist Intelligence Unit (EIU), 42 pp.
- EIU, 1994. Country Profile Tanzania Comoros 1994-95. The economist Intelligence Unit, 68 pp.
- Ellis, F. 1987. *Peasant economics: farm households and agrarian development*. Cambridge University Press, Cambridge.
- FAO, 1991. The impact of stabilization and structural adjustment policies on the rural sector. Case studies of Cote d'Ivoire, Senegal, Liberia, Zambia and Morocco. *FAO Economic and Social Development Paper* No.90, pp. 1-68.
- FAO/WHO, 1970-1982. *Annual Production YearBooks*. Food and Agriculture Organization of the United Nations, Statistical Series No 47. FAO, Rome.
- Feldstein, M.S. 1969. Mean variance analysis in the theory of liquidity preference and portfolio selection. *Rev. Econ. Studies* 36:5-12.
- Friedmann, H. 1980. Household production and the national economy: Concepts for the analysis of agrarian formations. *Journal of peasant studies*, Vol.7, No. 2.
- Friedrich, K. 1968. Coffee-banana holdings at Bukoba: the reasons for stagnation at a higher level. In: Ruthenberg H. (ed.) *Smallholder farming and smallholder development in Tanzania: ten case studies*, IFO, Munich.
- Geisler, G.G., B.B. Keller & P.M. Chuzu 1985. *The needs of rural women in Northern Province. Analysis and Recommendations*. NCDP & NORAD. The Government Printer, Lusaka.
- Gibbon, P., K.J. Havnevik & K. Hermele (eds.) 1993. *Blighted harvest?: The World Bank and African agriculture in the 1980's*. James Currey Ltd. and Africa World Press, London/Trenton 1993.
- Gillard-Byers, 1984. The allocation of resources in the nonmechanized small farm household of

- Dumila, Mkundi and Magole villages and the Kilosa District, Tanzania: A nutrition based approach. Thesis submitted in partial fulfillment of the requirements for the degree of Doctor of Philosophy in Agricultural Economics in the Graduate College of the University of Illinois at Urbana-Champaign, 1984.
- Gittinger, J.P. 1992. Economic analysis of agricultural projects. Second edition, completely revised and expanded. World Bank EDI in economic development. The Johns Hopkins University Press, Baltimore and London. 505 pp.
- Glen, J.J. 1987. Mathematical models in farm planning: A survey. *Operations Research* 35/5:641-666.
- Grainger, A. 1993. Controlling tropical deforestation. Earthscan Publications Ltd., London. pp 20-27.
- Gravelle, H. & R. Rees 1992. Microeconomics. Second edition Longman, London and New York pp. 752.
- Hamilton, A.C. & R. Bensted-Smith 1989. Forest conservation in East Usambara mountains. IUCN, Division of Forestry and Beekeeping, Dar es Salaam, 392 pp.
- Hamilton, A.C. & I.V. Mwashia 1989. History of resource utilization and management under German Rule. In: Hamilton A.C. & R. Bensted-Smith (eds.), Forest conservation in the Usambara mountains. IUCN, Division of Forestry and Beekeeping, Dar es Salaam, pp. 39-40.
- Hansen, S. 1993. Environmental and poverty crisis in the South. Miljø - og fattigdomskrise i sør - Et utviklingsøkonomisk perspektiv. Universitetsforlaget, Oslo. 247 pp.
- Hansen, S. 1994. Dialogue: Ecological and economic requirements for sustainable land use in sub-Saharan Africa. Some critical remarks to Jens B. Aune's analysis and Aune's clarifying remarks. *Forum for Development Studies* No. 1-2, 1994, p. 324-329.
- Hardaker, J.B. 1978. Farm planning by computer. Technical Bulletin No.19, Revised edition, Ministry of Agriculture, Fisheries and Food H.M.S.O., London.
- Harrison, P. 1987. The greening of Africa. Breaking through the battle for land and food. International Institute for Environment and Development. Earthscan, Paladin Grafton Books, London.
- Hartwick, J.M. and N.D. Olewiler 1986. The economics of natural resource use. Harper & Row, Publishers Inc. New York. 530 pp.
- Hayami, Y. and V.W. Ruttan 1971. Agricultural development: an international perspective. The Johns Hopkins University Press, Baltimore.
- Hayami, Y. and V.W. Ruttan 1984. Agricultural development: An International Perspective. Second edition. The Johns Hopkins University Press, Baltimore.
- Hazell, P.B.R. 1971. A linear alternative to quadratic and semivariance programming for farm planning under uncertainty. *American Journal of Agricultural Economics* 53:53-62.
- Heady, E.O. and W. Candler 1958. Linear programming methods. Iowa State College Press, Ames.
- Helmsing, A.H.J. 1989. Concepts and models of planning. In: H.G.T. van Raay, A.J. Dolman and C.M. Kazi (eds.) Tanzania Planner's Handbook. A guide for regional and rural development planning, Institute of Social Studies Advisory service (ISSAS), The Hague pp. 25-48.

- Hermansen, J.E.; F. Benedict; T. Corneliusen; J. Hofsten and H. Venvik 1985. Catchment forestry in Tanzania, status and management. NORAD Consultancy Report 17-18. Institute of Environmental Analysis and FORINDECO, Norway.
- Heyer, J., P Roberts and G. Williams 1981. Rural development in Tropical Africa. The Macmillan Press Ltd. London, 89 pp.
- Hiebert, L.D. 1974. Risk, learning, and the adoption of fertilizer responsive seed varieties. *American Journal of Agricultural Economics*, Vol. 56 No. 4.
- Hill, P. 1970. *Studies in rural capitalism in West Africa*. London, Cambridge University Press.
- Hillier, F.R. and G. Liebermann 1986. *Introduction to Operations Research*. Fourth edition. Holden-Day, Inc. Oakland, CA.
- Holden, S.T. 1988. Farming systems and household economy in New Chambeshi, Old Chambeshi and Yunge villages near Kasama, Northern Province, Zambia. An agroforestry baseline study. Agricultural University of Norway, NORAGRIC, Occasional Paper Series A No.9, 104 pp.
- Holden, S.T. 1991. Peasants and sustainable development: the Chitemene region of Zambia. Theory, Evidence and Models. Doctor Scientiarum Thesis. Department of Economics and Social Sciences, Agricultural University of Norway, Ås. 310 pp.+ app.
- How, R.B. & P.B.R. Hazell 1968. Use of quadratic programming in farm planning under uncertainty. Department of Agr. Econ. A.E. Res. 250, Cornell University.
- Hufschmidt, M.M., D.E. James A.D. Meister B.T. Bower and J.A. Dixon 1983. *Environment, natural systems, and development: an economic valuation guide*. The Johns Hopkins University Press, Baltimore and London pp. 1-71.
- Hunter, J. and C. Mabbs-Zeno 1986. African land tenure. *Agricultural Administration* 23:109-122.
- Hydén, G. 1980. *Beyond Ujamaa in Tanzania: Underdevelopment and the uncaptured peasantry*. Heinemann.
- Jerve, A.M. 1990. What sustains sustainable development?: The case of natural resource management in Tanzania. A paper presented to the conference on "Sustainable Development, Science and Policy", Bergen, 8-12 May 1990, 26 pp.
- Johnson, S. 1968. *The Green Revolution*. Harper and Row Publishers.
- Johnson, B.F. and W.C. Clark 1982. *Redesigning rural development: A Strategic Perspective*. The Johns Hopkins University Press.
- Johnston, B.F and P. Kilby 1975. *Agriculture and structural transformations: economic strategies in late developing countries*. Oxford University Press.
- Jones, W.O. 1960. Economic man in Africa. In: Shapiro K.H. 1974. *Efficiency and modernization in African agriculture: a case study in Geita District, Tanzania*. PhD dissertation, 1974, Stanford University, USA, University Micro Film International.
- Kalaghe, A.G.; T.H. Msangi & L. Johansson, 1988. Conservation of catchment forests in the Usambara mountains. *Tanzania Association of Foresters Journal* No. 6:37-47.
- Kamuzora, C.L. 1978. The dynamics of labour in African smallholder agriculture. The sources of labour for a new cash crop, tea, in Bukoba District, Tanzania. Unpublished PhD dissertation, University of Pennsylvania, USA.
- Kaoneka, A.R.S. 1990. Measures to contain the problem of encroachment in natural forests. *Sokoine University of Agriculture, Faculty of Forestry Record* No. 43:126-130.

- Kaoneka, A.R.S. 1993. Land use planning and quantitative modelling in Tanzania with particular reference to agriculture and deforestation: some theoretical aspects and a case study from the West Usambara mountains. Doctor Scientiarum Thesis. Department of Forestry, Agricultural University of Norway, Aas. 344 pp.+app.
- King, R.P. & L. Robinson 1981. Implementation of the interval approach to the measurement of decision maker preference. Research Report 418. Michigan State University Agricultural Experiment Station; Michigan State University.
- Kowal, J.M. & A.H. Kassam 1978. Agricultural ecology of savanna: a study of west Africa. Clarendon Press, Oxford, 403 pp.
- Kowero, G.S. 1990. Management and utilization of forest estates in Tanzania: some policy issues. *Journal of World Forest Resource Management*, 8(1):15-27.
- Krishina, 1965. In: Tibaijuka, A.K. 1984. An economic analysis of small-holder banana-coffee farms in Kagera region, Tanzania: causes of decline in productivity and strategies for revitalization. Unpublished dissertation submitted to the Department of Economics and Statistics of the Swedish University of Agricultural Sciences, Uppsala, in partial fulfillment of the requirements for the degree of Doctor of Philosophy. 214 pp+app.
- Kulp, E.M. 1970. Systems analysis and working method. Praeger Special Studies in International Economics and Development pp. 34-37.
- Lakshminarayan, P.G., J.D. Atwood, S.R.Johnson and V.A. Sposito 1991. Compromise solution for economic-environment decision in agriculture. *Journal of environmental management* 33:51-64.
- Lancaster, K. 1970. Introduction to modern microeconomics. Rand McNally & Company, Chicago.
- Latham, M.C. 1979. Human nutrition in tropical Africa. FAO Food and Nutrition Series , No. 11, Rome.
- Lele, U. 1975. The design of rural development: Lessons from Africa. The World Bank. The Johns Hopkins University Press, Baltimore and London, 226 pp.
- Lipton, M. 1968. The theory of the optimizing peasant. *Journal of Development Studies* 4(3):327-351.
- Lipton, M. 1979. Agricultural risk, rural credit, and the inefficiency of inequality. Ch.8 in Roumasset, J.A. 1979. Modelling decision making under uncertainty. Introduction and the state of the arts. In: Risk, uncertainty and agricultural development, ed, J.A. Roumasset, J.M. Boussard, I. Singh. Southeast Asian Regional Centre for Graduate Study and Research in Agriculture, Laguna, Philippines & Agricultural Development Council, New York.
- Low, A. 1986. Agricultural Development in Southern Africa: Farm-household economics and the food crisis. James Currey, London. pp. 13-47.
- Lovett, J.C. & D.W. Thomas, 1988. Report on the visit to Kanga mountains, Tanzania. *Eastern African Natural History Society Bulletin*, 18(2):19-22.
- LRDC, 1987. Land Resources Development Center. The Overseas Development Administration (ODA): Tanzania. Profile of agricultural potential (unpublished).
- Lundgren, B. 1985. Catchment forestry in Tanzania. A revised report for the joint Tanzania/Nordic forestry sector review 1985. Regional Soil Conservation Unit/SIDA, Nairobi.

- Mansfield, E. 1988. *Microeconomics theory/applications*. Sixth edition. W.W. Norton and Company, Inc., New York. 599 pp.
- Mansfield, E. 1991. *Microeconomics theory/applications*. Seventh edition. W.W. Norton and Company, Inc., New York. 556 pp.
- Markowitz, H.M. 1952. Portfolio selection, 7-77-91. Markowitz, H.M. 1959. Portfolio selection: Efficient diversification investments, New York, John Wiley & Sons.
- Mascarenhas, A. 1991. An overview of deforestation process in Tanzania. UNRISD Project: social dynamics of deforestation. Institute of Resource Assessment, University of Dar es Salaam, 51 pp.
- Masell, B.F. and R.W.M. Johnson 1968. Economics of smallholder farming in Rhodesia. In: Low, A. 1986. *Agricultural Development in Southern Africa: Farm-household economics and the food crisis*. James Currey, London. pp. 13-47.
- McFarquhar, A.M.M. 1961. Rational decision making and risk in farm planning: an application of quadratic programming in British arable farming. *Journal of Agricultural Economics* 14:552-563.
- McNamara, R. 1975. World development Report, World Bank, Washington D.C.
- MDB, 1993. Marketing Development Bureau, Ministry of Agriculture and Livestock Development, DSM Tanzania.
- Mellor, J.W. 1966. *The economics of agricultural development*. Cornell University Press.
- Mgeni, A.S.M. 1986. Planning forest investments with aid of quantitative models: A case study at Sao Hill Forest Project in Tanzania. Unpublished Ph.D. Thesis. Department of Forestry and Wood Science, University of North Wales, Bangor, Great Britain. pp. 5-38.
- Mgeni, A.S.M. and C. Price. 1993. Planning of forest plantation investments with the aid of linear programming: a case study of Sao Hill Forest, Tanzania. *Forest Ecology and Management* 62:51-72.
- Mitchell J.C. 1983. Case and situation analysis. *The Sociological Review* 31(2):187-211 (New Series).
- Mitzlaff, U.V. 1991. Managing the catchment forest reserves: who is to be involved? A socio-economic study prepared for the Catchment Forest Project, Forest and Beekeeping Division, Dar es Salaam, Tanzania. 35 pp.+ app.
- Mlambiti, M.E. 1985. Agricultural sector analysis for Kilimanjaro region: a basis for decision making and planning. Unpublished Ph.D. thesis. Department of Rural Economy, UDSM pp. 230+app.
- Mlambiti, M.E. (ed.) 1992. *The petals of Ulanga District: Potential, constraints, current resources utilization and food security situation of the district*. Published by Sokoine University of Agriculture, Morogoro-Tanzania, 153 pp.
- Mnzava, E.M. & P. Riihinen 1989. Forestry and land use policy and administration. Tanzania Forestry Action Plan (TFAP), Sector Review Mission Report No. 9. Forestry and Beekeeping Division, Ministry of Lands, Natural Resources and Tourism, 36 pp.
- Monela, G.C. 1995. Rainforest degradation and landuse in the Nguru mountains, Tanzania: Analysis of socio-economic and ecological aspects. Dr. Scient. Thesis submitted to the Department of forest Sciences, Agricultural University of Norway, Aas. Report No. 1.
- Moris, J.R. 1981. Managing induced rural development. International Development Institute,

- Indiana University.
- Mosher, A. 1966. Getting agriculture moving. Agriculture Development Council, New York.
- Mowo, J.G., J. Floor, F.B.S. Kaihura, and J.P Magoggo (eds.) 1993. Review of fertilizer recommendations in Tanzania. Part 2, Revised fertilizer recommendations for Tanzania. Soil Fertility Report No. F6. National Soil Service A.R.I. Mlingano, Ministry of Agriculture, Tanga, Tanzania, September 1993. 65 pp.
- MRCU, 1994. Morogoro Region Cooperative Union, Morogoro, Tanzania.
- Mukhebi, W.A. 1981. Income and employment generation in Kenyan smallholder agriculture. PhD Dissertation 1981. Washington State University, USA.
- Munasinghe, M. 1992. Environmental economics and valuation in development decision making. Environmental Working paper No.51. The World Bank Sector Policy and Research Staff, Washington D.C. pp.76.
- Mwalyosi, R.B.B. 1990. Interaction of pastoralism, agriculture, settlement and conservation in parts of the Maasai Steppe of Northern Tanzania. Dr. Scientiarum Thesis, Department of Biology and Nature Conservation, Agricultural University of Norway, 103 pp + app.
- Nakajima, C. 1965. Subsistence and commercial family farms. Some theoretical models of subjective equilibrium. In: Wharton C.R. Jr. ed. 1969. Subsistence agriculture and economic development, Aldine Publishing Company, Chicago.
- Nakajima, C. 1986. Subjective equilibrium theory of the farm household. *Developments in Agricultural Economics* 3. Elsevier Publishers, Amsterdam, 1-69 pp.
- National Agricultural Policy, 1982. The Tanzania National Agricultural Policy Report. Ministry of Agriculture, The United Republic of Tanzania.
- National Land Policy 1993, Second Draft. Ministry of Lands, Housing and Urban Development, DSM, Tanzania, May 1993.
- NBC, 1993. Tanzania National Bank of Commerce Ltd., Mwere Branch, Morogoro.
- NCSSD, 1994. Tanzania National Conservation Strategy for Sustainable Development. National Environment Management Council, January 1994. 58 pp.
- NEAP, 1994 National Environmental Action Plan, Tanzania. The National Environmental Policy. Division of Environment, MTNRE, United Republic of Tanzania. First Draft, 31 March 1994. 43 pp.
- Norman, D.W. 1974. Rationalizing mixed cropping under indigenous conditions: the example of Northern Nigeria: *Journal of Development Studies* Vol. 11.
- Norman, D.W. 1977. Economic rationality of traditional Hausa dryland farmers in the North of Nigeria. In: Stevens R.D. (ed.). *Tradition and Dynamics in Small-farm agriculture*. Ames: Iowa State University.
- Norris, S.R.V. 1990. Using aerial photographs and GIS in quantifying deforestation of tropical rainforest: A case study from the Nguru mountains, Tanzania. M.Sc. (MNRSA) Dissertation, NORAGRIC, Agricultural University of Norway, Ås, 120 pp.+ app.
- Nou, J. 1967. *Studies in the development of agricultural economics in Europe*. Uppsala, Almqvist & Wiksells Press.
- Nsolomo, V.R. & S.A.O. Chamshama, 1990. Human impacts on some catchment forest reserves in Morogoro region. *Sokoine University of Agriculture, Faculty of Forestry Record* No.43:39-45.

- Odero-Ogwel, L. and E. Clayton 1973. A regional programming approach to agricultural sector analysis. School of rural Economics and related studies, Wye College, University of London.
- O'Kting'ati, A. 1985. An analysis of the economics of agroforestry in Kilimanjaro. Unpublished Ph.D. Thesis. Faculty of Forestry, Sokoine University of Agriculture, Morogoro, Tanzania, 160 pp.
- Okoth-Ogendo, H.W.O. 1976. African land tenure reform. In: Heyer, Maitha & Senga eds. Agricultural Development in Kenya-an economic assessment. Oxford University Press, Nairobi.
- Omari, C.K. 1976. Strategy for rural development: Tanzania experience. East African Literature Bureau. Kampala, Nairobi, Dar es Salaam pp. 168.
- Openshaw, K. & J. Morris 1979. The socio-economics of agroforestry. In: International Cooperation in agroforestry. Proceedings of an international Conference, Kenyatta Conference Centre, Nairobi, Kenya, 16-21 July, 1979, eds. T. Chandler & D. Spurgeon.
- Øyhus, A.O. 1992. Adaptivity and rationality.: The Didinga ethno-agrarian mode of adaptation. A Doctor Scientarium Thesis submitted to the Department of Economics and Social Sciences, AUN Ås, Norway. 263 pp.
- Palgrave, 1987. The New Palgrave. A Dictionary of Economics. Vol. 1-4, The Stockman Press, New York.
- Palo, M. 1993. Population and deforestation. A final proposal for a forthcoming book on "The causes of Tropical Deforestation" edited by David Pearce & Kate Brown, published by UCL Press, London.
- Palo, M. & J. Salmi. (eds.) 1987. Deforestation or development in the Third World? Division of Social Economics of Forestry. The Finnish Forestry Research Institute, Helsinki Vol. I, 257 pp.
- Palo, M. & G. Mery (eds.) 1990. Deforestation or development in the Third World? Vol.III. Division of Social Economics of Forestry. The Finnish Forestry Research Institute, 189 pp.
- Paris, Q. 1979. Revenue and cost uncertainty, generalized mean-variance, and the linear complementarity problem. American Journal of Agricultural Economics 61:268-275.
- Paris, Q. 1989. Revenue and cost uncertainty, generalized mean-variance, and the linear complementarity problem: Reply. American Journal of Agricultural Economics 71:810-812.
- Poc's, T. 1976. Vegetation Mapping in the Uluguru mountains (Tanzania, East Africa). Boissiera, 24:477-498.
- Poc's, T. 1982. The forest flora and vegetation of the old crystalline mountains of Tanzania and their importance for soil and water conservation. In: seminar/workshop on forest conservation in Tanzania, Tanga 16-18 February, 1982, 5 pp.
- Poc's, T. 1988. The importance of catchment forests to Tanzania. Professorial Inaugural Lecture, Sokoine University of Agriculture, Morogoro; Tanzania, 11 pp.
- Poc's, T. 1990. The gene pool values and their conservation in the natural forests. Sokoine University of Agriculture, Faculty of Forestry Record No.43, pp. 16-32.
- Poc's, T.; R.P.C. Temu & T.R.A. Minja, 1990. Survey of the natural vegetation and flora of the

- Nguru mountains. In: I. Hedberg and E. Persson (eds.). Research for conservation of Tanzanian catchment forests. Proceedings from a workshop held in Morogoro, Tanzania, 13-17 March, 1989, Uppsala, pp. 135-149.
- Polak, A. 1986. Case studies and interview schedule surveys: A social anthropological approach to data collection in farmer oriented agricultural research. IRRI, Los Baños, Agricultural University, Wageningen. Royal Tropical Institute, Amsterdam (Mimeo).
- Prazmowski, A. 1987. Charting an emerging economy. The IDRC Reports, 16(3):10-11.
- Rajaraman, I. 1977. Growth and poverty in the rural areas of the Indian State of Punjab 1960/61-1970/71: In: Poverty and landlessness in rural Asia, ILO, Geneva 1977.
- Randall, A. 1987. Resource Economics. An approach to natural resource and environmental policy. Second edition. John Wiley & Sons, New York.
- Roberts, P. 1981. In: Heyer, J., P Roberts and G. Williams 1981. Rural development in Tropical Africa. The Macmillan Press Ltd. London pp. 89.
- Rodgers, W.A. & J.B. Hall 1986. Pole cutting pressure in Tanzanian forests. Forest Ecology and Management, 14:133-140.
- Romero, C. and T. Rehman 1984. Goal programming and multiple criteria decision making in farm planning: an expository analysis Journal of Agricultural Economics, 35:177-190.
- Romero, C.; F. Amador & A. Barco, 1987. Multiple objectives in agricultural planning: A compromise programming application. American Journal of Agricultural Economics, (1987):78-86.
- Roumasset, J.A. 1979. Modelling decision making under uncertainty. Introduction and the state of the arts. In: Risk, uncertainty and agricultural development, (ed.) J.A. Roumasset, J.M. Boussard, I. Singh. Southeast Asian Regional Centre for Graduate Study and Research in Agriculture, Laguna, Philippines & Agricultural Development Council, New York.
- Rudengrén, J. 1981. Peasants by preference? Socio-economic and environmental aspects of rural development in Tanzania. A dissertation for the Doctor's Degree in Economic Geography. EFI, The Economic Research Institute, Stockholm School of Economics 234 pp. + app.
- Ruthenberg, H. (ed.) 1975. Farming systems in the tropics. Third edition. Clarendon Press, Oxford.
- Rwechungura, C.C. 1985. Tanzania: landuse planning a major concern. Ministry of Agriculture and Livestock Development, Dar es Salaam. SPLASH 3(3):12-14.
- Sankhayan P.L., R.S. Prihar & H.S. Cheema 1988. Developing optimum cropping plans for a typical Punjab farm with multiple objectives using compromise programming. Indian Journal of Agricultural Economics 43:163-174.
- Sankhayan, P.L. & H.S. Cheema 1991. Using linear programming models for generating optimum farm plans: an expository analysis. Indian Journal of Agricultural Economics 46(4):601-612.
- Sankhayan, P.L. and R. Øygard 1993. Effects of structural adjustments on income, employment, risk and environmental degradation in Indian agriculture: a study in the Punjab. Unpublished report. Centre for Sustainable Development, Ås-NLH, 20 pp.
- Schluter, M.G.G. & T.D. Mount 1976. Some management objectives of the peasant farmer: an

- analysis of risk aversion in the choice of cropping pattern, Surat District, India. *Journal of Development Studies* 12(3):246-261.
- Schultz, T.W. 1964. *Transforming traditional agriculture*. Yale University Press.
- Shapiro, K.H. 1974. *Efficiency and modernization in African agriculture: a case study in Geita District, Tanzania*. PhD dissertation, 1974, Stanford University, USA, University Micro Film International.
- Shapiro, K.H. 1983. Efficiency differentials in peasant agriculture and their implications for development policies. *Journal of Development Studies* 19(2):179-190.
- Sharifi, M.A. and H. Van Keulen 1994. A decision support system for landuse planning at farm enterprise level. *Agricultural Systems* 45:239-257.
- Sharma, N. P. (ed.) 1992. *Managing the World's Forests. Looking for balance between conservation and development*. The World Bank. pp. 605.
- Simon, H.A. 1959. Theories of decision making in Economics and Behavioural Science. *The American Economic Review* 49 (June 1959), 253-283.
- Simmonds, N.W. 1985. *Farming systems research: A review*, The World Bank, Washington D.C.
- Sisay, A. 1980. *An economic analysis of household farm production in the Arssi region of Ethiopia: Cases from Chilalo Province*. PhD Dissertation 1980. Iowa State University, USA, Microfilm International.
- Siskos Y., D.K. Despotis and M. Ghediri 1994. Theory and Methodology. Multi-objective modelling for regional agricultural planning: Case study in Tunisia. *European Journal of Operations Research* 77:375-391.
- Solberg, B. 1988. Choice of technology in less industrialized countries with particular reference to forestry and sawmilling. Agricultural University of Norway, Department of Forest Economics, Ås-NLH. Report No. 3/1988. pp. 82-83.
- Somogyi, L. 1989. *Structural disequilibrium and adjustment: the case of Tanzania*. Text prepared for the seminar on "Agriculture Sector Analysis " July 1989, AICC, Arusha, Tanzania, 102 pp.
- Stiglitz, J.E. 1988. *Economics of the public sector*. Second edition, W.W. Norton and Company, New York. pp. 61-64.
- Stovall, J.G. 1966. Income Variation and risk of enterprises. *Journal of Farm Economics*, 48:1575.
- Swantz, M.L. 1984. *Women and development in Africa*. Unpublished seminar paper held at the Scandinavian Institute of African Studies, Uppsala, March 1984.
- Tang, A.M. 1965. On subjective Equilibrium of the subsistence farmer. In: Wharton, C.R. Jr., (ed.) 1969. *Subsistence agriculture and economic development*, Aldine Publishing Company, Chicago 1969.
- Tax, S. 1953. Penny capitalism. In: Schultz T.W. 1964. *Transforming traditional agriculture*. Yale University Press, New Haven, London.
- TFAP, 1989. *Tanzania Forestry Action Plan 1990/91-2007/08*. Ministry of Lands, Natural Resources and Tourism, 31 pp.
- Thorner, D., B. Kerblay & R.E.F. Smith 1966. *Chayanov on the theory of Peasant Economy: Homewood, Illinois: Richard D. Irwin*.
- Tibaijuka, A.K. 1984. *An economic analysis of small-holder banana-coffee farms in Kagera region, Tanzania: causes of decline in productivity and strategies for revitalization*.

- Unpublished dissertation submitted to the Department of Economics and Statistics of the Swedish University of Agricultural Sciences, Uppsala, in partial fulfillment of the requirements for the degree of Doctor of Philosophy. 214 pp+app.
- URT, 1978. Population census, United Republic of Tanzania, Bureau of Statistics. Ministry of Finance and Planning, Dar es Salaam, 29 pp.
- URT, 1988. Population census, United Republic of Tanzania, Bureau of Statistics. Ministry of Finance and Planning, Dar es Salaam.
- URT, 1991. Population census: National profile. Bureau of Statistics, President's Office. Planning Commission, Dar es Salaam, 26 pp.
- Van Lier, H.N. 1988. Landuse planning on its way to environmental planning. In: Whitby & Ollerenshaw (eds.). Landuse and the European environment, Bellhaven Press, London/New York, pp. 88-107.
- Villages & Ujamaa villages Act, 1975. An Act to provide for the registration of villages, the administration of registered villages and designation of Ujamaa villages. Act No. 21 of 1975, The United Republic of Tanzania.
- Wallman, S. 1979. Introduction in social anthropology of work, (ed.) S. Wallman 1-24. A.S.A. Monograph, 19. London, Academic Press.
- WCED, 1987. Our Common Future. The World Commission on Environment and Development. Oxford University Press, Oxford, New York, 400 pp.
- Webster, C.C. and P.N. Wilson 1980. Agriculture in the tropics. Second edition. Longman, London & New York. pp. 640.
- Willan, R.L. 1965. Natural regeneration of high forest in Tanganyika. East African Agriculture and Forestry Journal, 31:43-53.
- Williams, G. 1981. The World Bank and the peasant problem. In: Heyer J., P. Roberts and G. Williams (eds.) 1981. Rural development in Tropical Africa. The Macmillan Press Ltd. London pp. 89.
- Wolf, E.R. 1966. Peasants. Englewood Cliffs, New Jersey. Prentice Hall.
- Wolgin, J. M. 1975. Resource allocation and risk: a case study of smallholder agriculture in Kenya. American Journal of Agricultural Economics, Vol. 57 No. 5.
- Woods, R. Malthus, Marx and population crises. In Johnston, R.J. & Taylor, P.J. (eds.) A world in crises? Geographical perspective. Basil Blackwell Ltd. Oxford, UK, p. 127-149.
- World Bank, 1975. In: Lele, U. 1975. The design of Rural Development: Lessons from Africa. The Johns Hopkins university Press, Baltimore and London.
- World Bank, 1990. Making adjustment work for the poor: A framework for policy reform in Africa. A World Bank Study. The International Bank for Reconstruction and Development (The World Bank), Washington, D.C., 141 pp.
- World Bank, 1992. World Development Report 1992. Development and environment. Washington D.C.. Oxford University Press, 308 pp.
- Young, D.F. and P.A. Richards 1978. AGRIPLAN: A user's manual for small farm analysis. Farm management Unit, FAO Rome.
- Zekri, S. and C. Romero 1992. A methodology to assess the current situation in irrigated agriculture: an application to the village of Tauste (Spain). Oxford Agrarian Studies, 20(2):75-88.
- Zekri, S. and C. Romero 1993. Public and private compromises in agricultural water

- management. *Journal of Environmental management* 37:281-290.
- Zeleny, M. 1974. Concept of compromise solutions and methods of the displaced ideal. *Computer and Operating Research* (1): 479-496.
- Zeleny, M. 1976. The theory of the displaced ideal. *Multiple criteria decision making: Kyoto 1975*. Zeleny M. (ed.) Spring Verlag New York, 154-206 pp.
- Zeleny, M. 1982. *Multiple criteria decision making*. McGraw-Hill, New York.

APPENDIX 1.1 SAMPLE QUESTIONNAIRE FOR HOUSEHOLD DATA

QUESTIONNAIRE FOR HOUSEHOLD DATA

(This questionnaire is to be completed by the head of the household)

A.STRUCTURED QUESTIONNAIRE

1. HOUSEHOLD PARTICULARS

1.1 Location of household in altitude-based village strata

(a) lowland area.....

(b) upland area.....

1.2 Age of farmer

(a) 0-15 years.....

(b) 16-25 years.....

(c) 26-65 years.....

(d) Above 65 years.....

1.3 Level of education

(a) Illiterate.....

(b) Primary school leaver.....

(c) Secondary school leaver.....

(d) Other (specify).....

1.4 Marital status

(a) Married.....# of wives).....

(b) Unmarried.....

(c) Separated.....

(d) Other (specify).....

1.5 Head of Household

(a) Male.....

(b) Female.....

1.6 If female give reason

(a) Out-migration of husband.....

(b) widow.....

(c) separation.....

(d) Unmarried.....

(e) Other.....

1.7 Household/family composition

(a) Total number of people in the household.....

(b) Children and their ages (i) Males.....

(ii) Females.....

(c) Dependents and their ages (i) Males.....

(ii) Females.....

(d) Household members who live within.....

(e) Household members who live outside but remit money.....

1.8 Children attending school/colleges

- (a) primary school.....
- (b) secondary school.....
- (c) training institute.....
- (d) other.....

2. INCOME AND EXPENDITURE

2.1 Family/household main economic activities

- (a) Farming.....
- (b) Livestock keeping.....
- (c) Farming and livestock keeping.....
- (d) Employment (Specify).....
- (e) Wood cutting in the forest.....
- (f) Other activity.....

2.2 Sources of cash income for the household (T.Shs./year, month, season)

- (a) Sale of crops.....
- (b) Sale of domestic animals.....
- (c) Petty/commercial business.....
- (d) Casual employment.....
- (e) Remittances from relatives.....
- (f) Credit.....
- (g) Other.....

2.3 Household expenditures (T.Shs./year, month, season)

- (a) Farm inputs.....
- (b) Food purchase.....
- (c) Other consumer products.....
- (d) Obligatory levies.....
- (e) Cuts to payback subsidized farm inputs and credit.....

2.4 Frequency of crop sales

- (a) daily basis.....
- (b) only when need for cash arises.....
- (c) according to purchasing authority schedule.....
- (d) based on availability of customer.....
- (e) Other (specify).....

2.5 Farm income and expenditure summary

Farm Income (T.Shs.)				Farm expenditure (T.Shs.)			
Date	Description	Quantity sold	Total money received	Date	Description	Quantity	Total cost

2.6 Non-farm income and expenditure

Non-farm income (T.Shs.)			Non.farm expenditure (T.Shs.)		
Date	Description	Total income	Date	Description	Total expenditure

3. FARM PARTICULARS

3.1 Position of the farm holding by altitude

- (a) Lowland.....
- (b) Upland.....

3.2 Land slope and topography at the farm holding

- (a) Steep slope (> 15%).....
- (b) Moderate slope (5-10%).....
- (c) Gentle slope (< 5%).....
- (d) Ant-hills.....
- (e) Cracks in the soil.....

3.3 Location of farm in the landscape

- (a) On hill top or hillside.....
- (b) Adjacent to the forest reserve boundary.....

- (d) Beside the stream/river.....
- (e) Within the forest reserve boundary.....
- (f) Around homestead.....
- (g) Other (specify).....

3.4 If the farm holding is not around your homestead state the distance to the farm

- (a) < 2 km.....
- (b) 3-5 km.....
- (c) > 5 km.....

3.5 Why is your farm not around the homestead?

- (a) Lack of land near homestead.....
- (b) Is a traditional way of farming.....
- (c) Search for fertile land.....
- (d) Risk aversion (state the risk).....
- (e) Other.....

3.6 What is the actual size of your farm holding?.....
.....acres

3.7 Is farm size adequate? (a)Yes....(b) No.....

What is the method of land preparation.....

3.8 If no, why has farm size not increased over the years?

- (a) Lack of land.....
- (b) Lack of inputs.....
- (c) Age and poor health.....
- (d) Natural hazards.....
- (e) Drudgery.....
- (f) Other.....

3.9 How much additional land do you need?

- (a)Less than 1 acre.....
- (b)1-2 acres.....
- (c)2-3 acres.....
- (d)More than 3 acres.....

3.10 How is additional land acquired in this area?

- (a)bush clearing in open land.....
- (b)Clearing forest reserve.....
- (c)Clearing grassland.....
- (d)reverting to fallow land.....
- (e)buying.....
- (f)government allocation.....
- (g)Other.....

3.11 Summary of farm details

Plot No. and crop	Measured area of plot	Description (slope, soil type, trees, stones, anthills etc)

3.12 Loans details recording form

Date of loan	Purpose of loan	Amount borrowed (T.Shs.)	Source of loan	Amount owing at time of this study (T.Shs.)

4. SOIL CONDITIONS

4.1 Soil type

- (a) Loamy.....
- (b) Sandy.....
- (c) Clayey
- (d) Silty.....

4.2 Soil drainage in the farm holding

- (a) Good
- (b) Fair.....
- (c) Poor.....

4.3 Risk of soil erosion in the farm holding

- (a) High.....
- (b) Moderate.....
- (c) Low.....

4.4 Stones in the soil in the farm holding

- (a) Rocky.....
- (b) Stony.....
- (c) Hard pan.....

4.5 Soil moisture

- (a) High.....
- (b) Medium.....
- (c) Low.....
- (d) None.....

4.6 Organic material

- (a) High.....
- (b) Medium.....
- (c) Low.....
- (d) None.....

4.7 Colour of soil

- (a) Red.....
- (b) Brown.....
- (c) Grey.....
- (d) Brown-grey.....
- (e) Whitish.....
- (f) Dark.....

4.8 Soil fertility

- (a) High.....
- (b) Moderate.....
- (c) Low.....

5. PRODUCTION ACTIVITIES

5.1 Objectives of farming

- (a) Getting income.....
- (b) Subsistence.....
- (c) Is traditional occupation.....
- (d) Is government directive.....
- (e) Due to lack of skill for other jobs.....
- (f) Is a hobby.....
- (g) Other.....

5.2 Cropping systems (specify spatial and temporal spacing of crops)

- (a) Monocropping
- (b) Mixed cropping.....
- (c) Multiple cropping.....
- (d) Traditional agroforestry.....

5.3 If monocropping is practiced, why?

- (a) difference in crop requirements.....
- (b) to avoid yield loss due to shade and competition.....
- (c) ease of farm operations such as controlling weeds and harvesting
- (d) advice of extension officers.....
- (e) other.....

5.4 Reasons for mixed or intercropping

- (a) maximization of yield.....
- (b) maximization of labour.....
- (c) Risk aversion.....
- (d) Vermin control.....
- (e) to curb land shortage.....
- (f) Is a traditional way of farming.....
- (g) Other.....

5.5 Land allocation for each crop (by season, short rain or long rain)

- (a) Maize
- (b) Beans
- (c) Vegetables.....
- (d) Cassava.....
- (e) Rice
- (f) Coffee
- (g) Cardamon
- (h) Fruits
- (i) Trees
- (j) Other

5.6 Average harvest levels for a one year production cycle by season (kg,bags, m³/ha

- (a) Monocropping.....
- (b) Mixed cropping.....
- (c) Mixed cropping.....

5.7 Non crop farm outputs (kg, bags, headloads, m³/ha)

- (a) fuelwood.....
- (b) timber.....
- (c) fodder (herbage).....
- (d) crop residues.....
- (e) other.....

5.8 In what months and season does the following activities take place?

- (a) Land clearing.....
- (b) Land preparation
- (c) Manure application.....
- (d) Planting.....
- (e) First weeding.....
- (f) Second weeding.....
- (g) Fertilizer application.....
- (h) Spraying.....
- (i) Harvesting.....
- (j) Crop storage.....
- (k) Crop selling.....

5.9 How many animals do you own?

- (i) Cattle.....
- (ii) Goats.....
- (iii) Sheep.....
- (iv) Poultry.....
- (v) Pigs.....
- (vi) Other.....

5.10 Assets on hand at start of farming season (seed, fertilizer, tools and equipment, fences, buildings etc.)

Item and description	Quantity	Value at hand (T.Shs.)

5.11 Crop production summary

Total arable area cultivated.....ha, Total fallow area.....ha.

Plot & crop	Date planted	Seed		Manure applied (No. of carts)	Fertilizer applied (bags)				Chemicals (Type and quantity)	Total production (kg)
		Variety	Quantity (kg)		Initial		Top dressing			
					Type	Quantity	Type	Quantity		

6. LABOUR ISSUES

6.1 Main source of labour for the household

- (a) Family/household labour only.....
- (b) Hired labour only.....
- (c) Both household and hired labour.....
- (d) Draught animals.....

6.2 Activities by season

- (a) Activities for males
 - (i) During short rains.....
 - (ii) During long rains.....
 - (iii) During dry season.....
- (b) Activities for females
 - (i) During short rains.....
 - (ii) During long rains.....
 - (iii) During dry season.....

6.3 Activities by gender over the year

Month	Male activities	Female activities
January		
February		
March		
April		
May		
June		
July		
August		
September		
October		
November		
December		

6.4 How long does it take one adult person to complete one acre for each of the following farming activities?

Activity	Days per acre		
	Monocropping	Mixed cropping	Multiple cropping
Land clearing in new site			
Land clearing in used site			
Land preparation			
Manure application			
Planting			
First weeding			
Second weeding			
Fertilizer application			
Spraying			
Harvesting			

6.5 Division of labour by type in a household

Type of activity	Household members				Hired labour				Working parties			
	Male		Female		Male		Female		Male		Female	
	Men	Boys	Women	Girls	Men	Boys	Women	Men	Men	Boys	Women	Men
Feeding family												
Fuelwood & water												
Land preparation												
Sowing/planting												
Hoeing/Weeding												
Fertilizer applic.												
Spraying												
Harvesting												
Processing & Storage												
Marketing												
Cattle herding												
Tree planting												
Protecting trees												

6.6 Which are the busiest months in a year?

J F M A M J J A S O N D

.....

6.7 How much extra labour do you need during the busiest months?.....

6.8 Explain how extra labour is obtained.....

6.9 Form for weekly summary of labour, and equipment used

Week ending.....(day, month, year)

Date	plot number and crop	Hours worked by type of labour						Tools and equipment used	Payments made (T.Shs.)	Payments received (T.Shs.)
		Farming	Domestic chores	Leisure	Off-farm activities	Hired	Other			

7. CONSUMPTION AND SALE ACTIVITIES

7.1 Crops for consumption (kg/week, month, year)

(a) Maize.....

(b) Beans.....

(c) Vegetables.....

- (d) Cassava.....
- (e) Rice.....
- (f) Other.....
- 7.2 Crops for sale in open market (kg/week, month, year)
 - (a)Maize.....
 - (b)Beans.....
 - (c)Rice.....
 - (d)Cassava.....
 - (e)Vegetable....
 - (f)Coffee.....
 - (g)Fruits.....
 - (h)Cardamon.....
 - (i)Cocoa.....
 - (j)Other.....
- 7.3 Fuelwood consumption
 - (a) Travel distance to collect fuelwood.....
 - (b)Headloads per week.....
- 7.4 What are the usual crop disposal channels?
 - (a)Open market.....
 - (b)Official market.....
 - (c)Parallel market.....
- 7.5 What increase in producer prices would induce you to expand production of your farm?
 - (a)Price increased by one quarter.....
 - (b)Price increased by half.....
 - (c)price increased by one third.....
 - (d)Twice the present price.....
 What method would you normally use to achieve this?
 - (a) Intensify farming in the current land holding by shortening the fallow period
.....
 - (b) Expand the current farm by clearing natural forest
.....
 - (c) Increase use of farm inputs.....
 - (d) Move the farm to high yield potential areas.....
 - (e) Reduce the demand for land.....
 - (f) Other (specify).....
- 7.6 If food is not enough which months in a year you face the problem?
- 7.7 Food consumption in the family
 - (a)father.....kg/day
 - (b)mother.....kg/day
 - (c)lactating/expectant mother.....kg/day
 - (d)Children (under 15 years).....kg/day
 - (e)infants.....kg/day

8. LAND RIGHTS

- 8.1 How was land of your farm holding acquired?
- (a) Inheritance.....
 - (b) Bought.....
 - (c) Village offer(Government allocation).....
 - (d) Lease.....
 - (e) Clearing natural forest.....
 - (f) Other.....
- 8.2 What institutional rights do you have over your farm holding?
- (a)have title deed.....
 - (b)have property right on the land as long as I am using it.....
 - (c)village protects all my land rights against intrusion.....
 - (d)have customary rights
 - (e)No rights.....
- 8.3 How have insecure land rights influenced your investment decisions with regard to the following?
- (a)Tree planting in the farm.....
 - (b)Improving farming methods.....
 - (c)Expanding the farm.....
 - (d)Soil conservation measures.....
- 8.4 Who owns household land?
- (a)Household head.....
 - (b)Spouse.....
 - (c)Both.....
 - (d)Other family members.....

9. LAND MANAGEMENT

- 9.1 Actual land use classification (ha)
- (a) Settlement.....
 - (b) Cultivated land.....
 - (c) Forested land.....
 - (d) Livestock grazing land.....
 - (f) Barren and waste land.....
 - (g) Recreational land.....
 - (h) Mineral land.....
 - (i) Commercial land.....
 - (j) Other.....
- 9.2 Do you use these techniques to replenish the soil in your land holding?

- (a) Fallow.....ha
 - (b) Manure....ha (i) Animal dung....kg,tins,bags/year,season
(ii)Green manure....kg,tins,bags/year,season
 - (c) Chemical fertilizer....ha(i) SA.....kg,bags/year,season
(ii)TSP.....kg,bags/year,season
 - (iii)Other...kg,bags/year,season
 - (d) Pesticides.....ha.....kg,tins,liters/year,season
 - (e) Soil erosion control.....ha
 - (i) Terracing.....ha
 - (ii) Contour ridging.....ha
 - (iii) Strip cropping.....ha
 - (iv) Other measures.....ha
 - (f) Agroforestry.....ha
- 9.3 If you do not use fertilizer or manure, why?
- (a)Soil is naturally fertile.....
 - (b)Fertilizer or manure is not available.....
 - (c)Lack of money to afford the price.....
 - (d)Do not need fertilizer or manure.....
 - (e)Do not know.....
- 9.4 Land tillage and planting techniques
- (a) Ridges.....
 - (b) Flat land tillage.....
 - (c) Planting in rows.....
 - (d) Planting by broadcasting.....
 - (e) Strip planting.....
- 9.5 Is your land holding in a single block?
- (i) yes..... (ii)No.....(iii)Not available.....
- 9.6 If no, how many plots do you have?.....

Plot No.	Plot size(ha)	Area under cultivation (ha)	Years of cultivation	Cropping pattern	Major crops	Harvest (bags,kg)

9.7 If some plots are not used, why?.....